

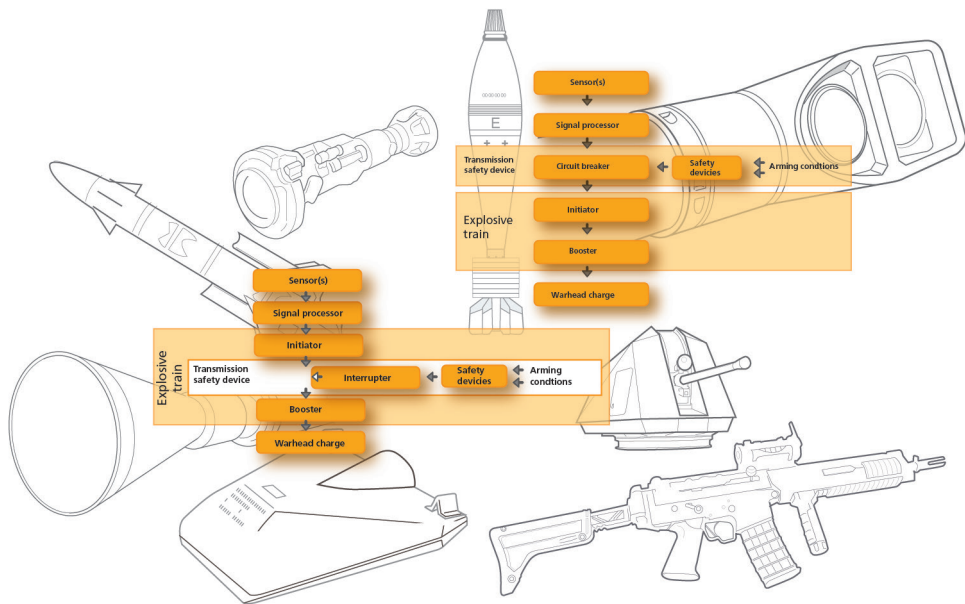

Weapons and Ammunition Safety Handbook



**Swedish Defence Material
Administration's Weapons and
Ammunition Safety Handbook**

H V A S E 2020

Readers' Guide

1. Introduction

2. Safety activities and requirements common to all materiel

3. Weapons

4. Ammunition

5. Summary of requirements/checklist

Appendix 1. Definitions

Appendix 2. Acronyms

Appendix 3. Standards

Appendix 4. References



Datum	Diarienummer	Ärendetyp
2021-03-18	21FMV679-2:1	3.5
	Dokumentnummer	Sida
	ange	1(1)
Giltig t.o.m.	Upphäver	
Tills vidare	H VAS E 2012	

Beslutande

Gustaf Fahl

Föredragande

Svante Wåhlin

Approval of Weapons and Ammunition Safety Handbook 2020 (H VAS E 2020)

The Weapons and Ammunition Safety Handbook, H VAS E 2020, (English edition), M7762-001201, is hereby approved for use. At the same time, the previous edition H VAS E 2012 (M7762-000881) is withdrawn.

This English edition is a translation of the Swedish Handbok Vapen- och Ammunitionssäkerhet 2020 (H VAS 2020, M7762-001191), approved for use in decision 20FMV147-2:1, 2020-06-24.

In case of difficulties or ambiguities with regard to interpretation, the Swedish edition applies and takes precedence.

The decision has been prepared by Svante Wåhlin, LOG /Requirements and Methodology.

FÖRSVARETS MATERIELVERK

Gustaf Fahl
Chief Technical Officer

READER'S GUIDE

H VAS can be read a first time in its entirety and it can then act as a reference guide and as a checklist.

This handbook comprises both descriptive and requirement-based chapters as described below.

Chapter 1, 'Introduction' describes the background, preconditions and objectives of the handbook.

Chapter 2, 'Safety activities and requirements common to all materiel' specifies weapon and ammunition related safety activities and how they can be conducted in the most suitable manner.

Chapter 3, 'Weapons' specifies equipment related requirements for weapons of which the main sections are *Common requirements* and *System requirements*.

Chapter 4, 'Ammunition' specifies equipment related requirements for ammunition. With regard to ammunition the specific subsystem requirements also apply. These are specified under the respective headings *Warheads*, *Propulsion systems*, *Fuzing systems* and *Packaging*.

Chapter 5, 'Summary' of all of the handbook's requirements. Used as a checklist, e.g. when presenting a system to advisory groups. It is also available in Word format on FMV's website.

Appendix 1, 'Definitions' defines specific terms.

Appendix 2, 'Acronyms' contains certain abbreviations and acronyms.

Appendix 3, 'Standards' relates to relevant standards known at the time of the publication of the handbook.

Appendix 4, 'References' provides references to literature relating to defence materiel.

For some systems it may be difficult to determine where the boundary is between weapons and ammunition. In such cases it is essential that both *Chapter 3 Weapons* and *Chapter 4 Ammunition* are applied.

The Weapons and Ammunition Safety Handbook (H VAS E) is based on – and is a complement to – the System Safety Handbook (H SystSäk E). Both handbooks are co-ordinated and are designed to be used together. H VAS E can however be read and applied independently.

REVISION HISTORY

FMV'S first handbook in this area, The Ammunition Safety Handbook, was published in 1976. A revised edition was produced in 1990. After expanding the scope, a Handbook for Weapons and Ammunition Safety, H VAS, 2000 was published, which was followed by a revised edition in 2012. This present edition, H VAS 2020, is thus the fifth edition in the area.

IMPROVEMENT SUGGESTIONS

Comments and suggestions for improvements to H VAS E 2020 should be sent to FMV, 115 88 Stockholm or systemsakerhet.fmv@fmv.se (“Improvement proposal H VAS”).

Content

Reader's guide	3
0 To Our Foreign Reader	9
0.1 Purpose of this chapter.....	9
0.2 Defence Materiel Systems Procurement	9
0.3 About the Handbook	10
1 Introduction	11
1.1 Risk, Accident, Safety.....	15
1.2 Risk Management	17
1.3 Responsibilities and Authority at FMV	19
2 Safety Activities and Requirements Common to all Equipment.....	21
2.1 Safety Activity Requirements.....	22
2.2 Requirements Common to all Equipment.....	24
2.3 Requirements of International Law	25
2.4 System Safety Requirements in Operational Requirements	27
Application of civil requirements for weapons and ammunition.....	27
2.5 Determining Requirements for the Request for Proposal (RFP) ..	30
2.6 Independent Review	32
Advisory Group for Fuzing systems (Rg T)	33
Advisory Group for Warheads and Propulsion Devices (Rg V&D)	35
Advisory Group for Explosives (Rg Expl)	37
2.7 Safety Testing and Safety Analyses	41
2.8 Safety Surveillance.....	43
2.9 Training Safety Regulations (TSR)	43
3 Weapons.....	45
3.1 Common requirements relating to weapons	47
Danger area.....	47
Safety of friendly forces.....	49
Toxic substances	51
Electrical and magnetic fields	54
Robustness to extreme climatic conditions	55
Fire.....	55
Sound pressure	57
Back blast.....	59
Vibration dose.....	59
Pressure.....	60
Spring forces	60
Hydraulic and pneumatic forces.....	62
Recoil forces.....	63

	Other forces	64
	Lasers	64
	Mechanical stability	67
	Transport	68
3.2	Firearms, cannons and missile launchers	69
	Weapon installation	70
	Breech mechanisms.....	70
	Firing mechanism	71
	Breech ring	73
	Obturation	73
	Secondary combustion	74
	Barrel wear.....	75
	Barrel fatigue.....	76
	Barrel rupture.....	76
	Cook-off	77
	Fume evacuators	78
	Muzzle brakes, flame guards and recoil amplifiers	78
	Muzzle flash.....	80
	Sub-calibre barrels.....	80
	Ramming	81
	Recoil brakes.....	82
	Composite and compound barrels.....	83
	Recoilless weapons and rocket systems.....	83
3.3	Other weapon systems.....	85
	Minelayers for anti-tank mines.....	85
	Launching equipment for underwater mines/depth charges ...	86
	Launch devices for torpedoes	87
	Launchers and pylons.....	90
	Weapon platforms.....	91
	Openings/hatches and doors.....	92
	Sights and aiming systems	92
	Guidance and control systems	93
3.4	Other.....	96
	Pressure vessels.....	96
	Lifting devices	97
	Fire-fighting equipment	98

4	Ammunition	99
4.1	Common Ammunition Requirements	100
	Insensitive Munitions (IM)	100
	Additive manufacturing of explosives.....	101
	Batteries	102
	Chemical legislation and FMV’s chemical management	104
	Other ammunition common requirements.....	109
4.2	Warheads	112
	Environments for warheads.....	113
	Joint requirements for warheads	114
	Warheads containing High Explosive (HE)	117
	Pyrotechnic warheads.....	128
	Other warheads.....	135
4.3	Launching and propulsion systems.....	136
	Environment for launching and propulsion systems	137
	Joint requirements for launching and propulsion systems....	139
	Propulsion devices in tube-launched ammunition.....	141
	Propulsion devices and gas generators for rockets, guided missiles, unmanned vehicles, torpedoes, etc	144
4.4	Fuzing systems	155
	Environments for fuzing systems	160
	Common requirements for fuzing systems.....	163
	Mechanical subsystems	176
	Electrical subsystems	178
	Electronic and software controlled subsystems.....	182
	Subsystems with wave-borne signals	196
	Laser fuzing systems.....	197
	Fuzing systems for other types of ammunition	198
4.5	Packaging for ammunition	203
	Environmental factors.....	204
	Joint requirements for packaging for ammunition.....	206
	Common requirements for ammunition in packaging	208
5	Summary of requirements/Checklist.....	209
5.1	Common	209
5.2	Requirements in Chapter 2 Safety Activities and Requirements Common to all Equipment	209
5.3	Requirements in Chapter 3 Weapons	213
5.4	Requirements in Chapter 4 Ammunition	240
Appendix 1	Definitions	291
	Terminology	291
Appendix 2	Key to abbreviations	321

Content

Appendix 3 Standards	325
EU/EDA standardization work in this area	326
NATO's standardization work in this area	327
Examples of standards	329
Standards relating to design and testing	329
System specific methods for environmental testing of ammunition	333
Environment specific methods	334
Appendix 4 References	341
Documents governing safety	343
Design principles and experience	344
Textbooks	345
Documents relating to the environment	346
Accident investigations	348

0 To Our Foreign Reader

This chapter exists in the English edition only.

0.1 PURPOSE OF THIS CHAPTER

The purpose of this chapter is to inform our Foreign Readers on some facts about the role-play in Sweden concerning Weapons and Ammunition procurement.

0.2 DEFENCE MATERIEL SYSTEMS PROCUREMENT

The Swedish Defence Materiel Administration (FMV) is an independent agency for procurement of materiel for the Armed Forces on assignment from the Head Quarters (HQ).

An assignment is formulated as an agreement between the HQ and FMV in each case, defining the scope of work and reached after a dialogue regarding technical, financial and time aspects. To define the task, the HQ issues Operational Requirements, which could be compared to a specification in a business agreement.

The responsibility for the defence procurement extends to the technical processing (e.g. producing technical specifications), negotiating contracts, purchasing, testing and inspection of equipment. Being a governmental agency, FMV neither manufactures nor sells anything, nor has it resources for design (but quite a lot for testing). FMV contracts the industry, mostly in competition and strictly obeying the Public Procurement Act, based on EU directives. After contracting a supplier, FMV monitors and controls the safety work performed by the supplier.

0.3 ABOUT THE HANDBOOK

During the late sixties and early seventies, a number of ammunition related accidents occurred in Sweden. As a result of the investigations of the accidents, an Ammunition Safety handbook was issued. The purpose of the handbook was to prescribe a procedure that would ensure an acceptable level of safety throughout the life of the ammunition and to lay down basic safety requirements for ammunition.

The handbook was based on a record of experience gained over the years. It contained a list of technical requirements, some mandatory and some desired. Many of the requirements were of the prohibiting type. The handbook has been updated regularly and each time been issued an English versions.

A number of years ago we had reports on some failing artillery pieces. We also carried out safety investigations on some older artillery systems. Reflecting the obvious advantages of the ammunition safety methodology Sweden had gained until then, the natural question was ‘Why only ammunition?’. We were aware of the growing complexity of modern systems and also the impact from the use of software. Hence, the handbook since 2000 includes requirements and experiences from both ammunition and weapons.

Chapter 1 ‘Introduction’ describing the background, preconditions and objectives of the handbook.

The Weapons and Ammunition Safety Handbook provides a compilation of the experiences gained relating to safety shortcomings observed over the years. This handbook should be regarded as a complement to the Swedish Armed Forces’ System Safety Handbook (H SystSäk E). The System Safety Handbook (H SystSäk E) shall always be applied. If the technical system contains weapons and/or ammunition, this handbook, H VAS E, shall be applied as well.

As a result of a proposal in the final report produced by the Ammunition Safety Working Group (ASWG – dated 28/09/1970) with representatives from the Defence Materiel Administration (FMV), the then former Defence Research Establishment (FOA) and the Swedish defence companies concerned, a handbook (the Weapons and Ammunition Safety Handbook) was compiled at the beginning of the 1970s based on experience accumulated from the ammunition sector. The handbook is developed successively at intervals of about ten years. The edition released in the year 2000 was designed to include weapons, which is logical as the border between weapons and ammunition is becoming increasingly blurred. A new edition of H VAS, with relatively extensive changes, was published in 2012. This present edition is a revision of H VAS 2012 (Weapons and Ammunition Safety Handbook 2012).

The purpose of the Weapons and Ammunition Safety Handbook is:

- to complement the System Safety Handbook (H SystSäk E) with respect to weapons and ammunition,
- specify the necessary activities to ensure that weapons and ammunition obtain tolerable level of risk throughout their life span,
- provide basic safety related design requirements relating to weapons and ammunition,
- to act as a guide and checklist for personnel of the armed forces (FM), FMV, FOI and suppliers for issues concerning safety in connection with the development, procurement, manufacture, management and decommissioning of weapon systems and ammunition.

This handbook specifies the requirements relating to the activities that need to be carried out for the development and procurement of weapons and ammunition as well as the requirements relating to safety features. The requirements referred to cover all phases of service life.

In accordance with current practice, the safety requirements in this handbook are subdivided into *mandatory (shall)* and *desired (should)* requirements. The requirement specification in the order/contract shall state which requirements, and the type of requirement (mandatory or desired) that shall apply for specific weapons and/or a specific munition.

H VAS E in itself is not a governing document, which means that the requirements set out in the handbook and the levels of stringency (mandatory or desired) only provide guidelines for the preparation of requirement specifications. However weapons and ammunition safety activities are governed within FMV by specific regulations. See also *Section 1.3* below.

Figure 1:1 illustrates schematically the connection between H VAS E and other handbooks that govern and affect weapons and ammunition safety activities.

The System Safety Handbook (H SystSäk) states how system safety activities can be appropriately conducted, it also contains certain materiel specific requirements.

The Vehicle Safety Handbook (H FordonSäk) states the design principles for, and experience accumulated from, the development of vehicles as well as regulations governing road worthiness.

Handbook on Software in Safety-critical Applications (H ProgSäk) sets guidelines in setting requirements for and handling of software in safety-critical applications.

Handbook on Safe Field-based Workplaces (H Säk Fältm Arb) provides guidance in setting requirements to avoid ill health and accidents when designing field workplaces in a military environment.

Handbook on Safe Electrical Products and Systems (H SEPS)¹ provides guidance in setting requirements for this type of equipment for use in military applications.

These handbooks are used as a complement to the Weapons and Ammunition Safety Handbook when formulating technical requirements and requirements for operational undertakings.

1. The book is not translated to English (2020), but the requirements are.



Figure 1:1 H VAS E relationship to other handbooks, principle figure

Weapons and ammunition safety activities are governed within FMV by specific regulations. These state that the Weapons and Ammunition Safety Handbook shall be applied during the procurement of weapons and ammunition.

When a system is to be procured the contract stipulates that a System Safety Program Plan (SSPP) shall be established. The SSPP then governs other safety-related activities. The System Safety Handbook and the Weapons and Ammunition Safety Handbook provide guidance concerning which activities and overall requirements that should or shall apply. See also *H SystSäk E*.

1.1 RISK, ACCIDENT, SAFETY

Risk refers to the combination of the probability that a hazardous event shall occur and the consequences of this supposed event. A hazardous event is defined as a related undesired (inadvertent) event.

An *accident* is defined as a hazardous event or series of events which cause unacceptable injury to a person, damage to property or damage to the environment. For it to be deemed an accident it is necessary that someone/something has been exposed to a hazardous event.

Example: If a shell detonates at an undesired point in time, or at an undesired place, it is regarded a hazardous event. However, if no person is injured and no materiel/property or the environment is exposed and injured/damaged by the detonation, the event is regarded an incident.



Figure 1:2 The ‘accident’ concept

Weapons and ammunition safety is a property or state of the equipment which when handled under specified conditions does not result in a *hazardous event* or that parts or components are not affected in such a way that a hazardous events may occur through subsequent handling.

1 Introduction

Examples of typical factors affecting the stated specific safety conditions include:

- safety of devices for the handling of weapons and ammunition is satisfactory,
- requisite training has been completed by the users,
- specified environmental limits have not been exceeded,
- the equipment has been used and operated as intended, i.e. user instructions have been followed,
- in-service surveillance and status checks have been performed as necessary.

Handling refers to handling during all phases throughout the life of the equipment, e.g. storage, transport, operation, maintenance and disposal.

Weapons and ammunition safety is only one of many safety concepts. An explanation of how this safety concept can be related to other safety concepts is provided below.

The concepts below may constitute parts within a major system such as a naval vessel. In such a case, seaworthiness, ammunition safety, and weapons safety are constituent parts of the wider system safety concept for the vessel. System safety may also encompass further concepts such as software safety, robustness to environmental conditions, and activities for the protection of the environment.



Figure 1:3 System safety exemplified by a naval vessel system

The seaworthiness of the vessel is affected in this example directly by weapons and ammunition safety. For example, if it is possible to fire a gun on board a vessel towards the deck resulting in damage to the hull, or if the ammunition is unable to withstand environmental stresses (e.g. vibration) resulting in an inadvertent detonation. Also see *Appendix 1 Definitions*.

1.2 RISK MANAGEMENT

All activities involving technical systems contain risks. Complete absence of risk is therefore often an unattainable “ideal state” hence the objective of risk-reducing activities and actions is to identify and reduce risks to a tolerable level.

A tolerable risk level shall be defined early and determined by the Armed Forces (FM) in the Operational Requirements (SMS) or equivalent document.

The purpose of the weapons and ammunition in the Armed Forces is to inflict the maximum possible damage on the enemy. Consequently, weapons and ammunition often constitute a potential hazard even to the user. The requirements specified for performance and reliability can be contradictory to requirements stipulated for safety since safety devices can entail a lower level of reliability and operational availability.

All accidents are unwanted and costly. Accidents with weapons and ammunition usually produce serious consequences, which is why safety requirements must be stringent. Accidents with weapons and ammunition also lead to decreased confidence in the equipment. Hence, safety must be maintained at an acceptable level throughout the weapons and ammunition service life.

In addition to the requirements in H VAS E, H SystSäk E, and other publications, there are a number of laws which must be taken into account, such as the Work Environment Act (Arbetsmiljölagen – AML), the Flammable and Dangerous Goods Act (Lagen om brandfarliga och explosiva varor – LBE), and the Transport of Dangerous Goods Act (Lagen om transport av farligt gods – LFG).

In order to comply with the requirements of the Armed Forces relating to the level of risk, it is assumed, among other things, that:

- system specific safety requirements and requirements for safety activities are formulated by the Armed Forces as part of Operational Requirements (SMS) or equivalent.
- FMV translates the requirements of the Armed Forces into technical requirements by using the Weapons and Ammunition Safety Handbook and other applicable specifications and standards. All of these safety requirements are specified by FMV in the Request for proposal (RFP) for suppliers.
 - FMV assures that weapons and ammunition conform to the safety requirements set out in the RFP or equivalent and H VAS E; that safety activities are being carried out in accordance with the technical system's SSPP in a satisfactory manner and that support documentation for the Armed Forces' Central Safety Compliance Decision (CSSB) is developed, for example proposals for usage instructions.
 - The supplier ensures that weapons and ammunition meet the safety requirements stated in requirement specifications and that the activities agreed in the SSPP are properly performed.
- The Armed Forces shall ensure that training equipment and plans, safety regulations and user instructions are available so that military units can use the equipment in a safe manner.
 - That users are provided with sufficient training and ensure that conditions during usage are in accordance with the requirements set out in SMS.
 - The users complies with the instructions given during training and with safety regulations when handling the weapon and ammunition.
- Explosives are approved and given relevant classification by MSB.
- The Armed Forces assign FMV the task of disposal of weapons and ammunition.

It is essential that all parties involved are aware of their responsibility for ensuring that weapons and ammunition are acceptably safe to handle throughout their service life.

1.3 RESPONSIBILITIES AND AUTHORITY AT FMV

Responsibility for weapons and ammunition safety devolves upon the unit within FMV which:

- has the assignment to procure or modify the weapons and ammunition,
- has a mandate to integrate weapons or ammunition on a larger system,
- has production or product responsibility for the system in which the weapon/ammunition is included.

Responsibilities and authority related to FMV's weapons and ammunition safety activities are governed by FMV's specific regulations.

After completion of the system safety activities a Safety Statement (SS) shall be issued as specified in the Armed Forces' System Safety Handbook.

Advice concerning weapons and ammunition safety shall be obtained from FMV's advisory groups for ammunition safety in accordance with FMV's specific regulations concerning ammunition safety. The independent review in the advisory groups is made in accordance with the requirements in H VAS. It is worth noting that advice given by the advisory groups does not alter the responsibility of the project manager although it is not formally compulsory for the project manager to follow the advice obtained.

2

SAFETY ACTIVITIES AND REQUIREMENTS COMMON TO ALL EQUIPMENT

This chapter specifies the safety activities and requirements that are specific to weapons and ammunition. It is necessary to analyse which of these that must be implemented in order to obtain a tolerable level of risk. *Section 2.1* specifies safety activity requirements and *Section 2.2* the requirements common to all equipment.

For the acquisition of a larger system, activities that are specific to weapons and ammunition shall be integrated with the project's activities. It is appropriate that this integration is carried out by incorporating the specific activities in the project's System Safety Program Plan (SSPP), see the System Safety Handbook. For example, only weapon and ammunition specific requirements are stated in this handbook while the overall requirements are stated in the System Safety Handbook. Sometimes the line between the System Safety Handbook and the Weapons and Ammunition Safety Handbook (H VAS E) is difficult to define. Such a problem arises, for example, with the integration of a weapon with a platform.

In this handbook, consideration is given to the procedures and standards that are in use internationally; consequently the handbook is applicable in its entirety even during procurement from an international supplier and in cooperation with other nations.

The handbook contains requirements for procurement. Every section contains facts and explanatory text followed by requirements. If applicable or necessary, the requirements are also commented.

2 Safety Activities and Requirements Common to all Equipment

The requirements in the handbook are numbered according to the following principle/example. In requirement 1.203.003 A is stated:

- 1 that the requirement is found in H VAS,
- 203 that the requirement is found in Chapter 2, Section 3,
- 003 the serial number of the requirement,
- A Administrative requirement (usually included in Business Obligation Specification, OUR) or
- T Technical requirement (usually included in the Technical Specification).

2.1 SAFETY ACTIVITY REQUIREMENTS

In view of their nature and purpose, weapons and ammunitions possess hazards which are necessary in order to achieve the desired combat effect.

However, the risks pertaining to a weapon and ammunition system from a life cycle perspective can partially be eliminated or limited. During design and manufacture, most risks can be mitigated through design measures and effective production control.

Certain risks may remain after delivery. These risks are reduced through restrictions on use and safety regulations, and through training in handling of the system.

The objective of the System Safety activities is to provide a tolerable level of risk for personnel, equipment, property and the environment.

Required safety activities to be carried out shall, where applicable, be included in the SSPP.

- 1.201.001 A System safety requirements **shall** be specified in the Request for Proposal (RFP) in accordance with *Section 2.5*.
- 1.201.002 A For explosives, advice **shall** be obtained from FMV's Advisory Group for Explosives. See also *Section 2.6.3*.
- 1.201.003 A Advice from FMV's other advisory groups for ammunition safety **shall** be obtained when appropriate. See *Section 2.6*.
- 1.201.004 A Safety testing **shall** be performed by the supplier as part of the safety verification. See also *Section 2.7*.
- 1.201.005 A Test directives for safety inspections (part of the In-Service Surveillance of Ammunition) **shall** be produced in conjunction with the procurement. See also *Section 2.8* and the *FMV Handbok Ammunitionsovervakning (FMV H AmÖ)^a*.
- 1.201.006 A Supply classification data **shall** be provided and registered in current register.
- 1.201.007 A Draft handling, maintenance and user instructions **shall** be provided.
- 1.201.008 A Safety Statement **shall** always be submitted for ammunition

a. FMV Handbook of Regulations for In-Service Surveillance of Ammunition, (not available in English)

2.2 REQUIREMENTS COMMON TO ALL EQUIPMENT

- 1.202.001 T Incorporated explosives **shall** be qualified in accordance with FSD 0214, STANAG 4170 or equivalent.
Comment: Assessments relating to the scope of the qualification are carried out where appropriate by FMV's Advisory Group for Explosives, see *Section 2.6.3*.
- 1.202.002 T Incorporated materials **shall** be compatible so that the product remains safe during its lifetime.
Comment: Incompatible materials are to be avoided even if their reaction products are harmless. During compatibility testing, all of the organic materials used in the explosives along with other safety critical components are often analysed. This applies to materials that are in direct contact with each other or that can be affected via exchange of gases or liquids.
- 1.202.003 T The product **shall** retain its safety properties for at least as long as its specified service life.
- 1.202.004 T Service life and compatibility testing **shall** be carried out in accordance with FSD 0223 or equivalent.
- 1.202.005 T Environmental requirements **shall** be specified as part of the procurement. The Defence Sector's criteria documentation **shall** be followed and any exceptions approved and documented.
- 1.202.006 T When procuring or modifying ammunition or explosive goods, information and/or reference materiel **shall** be procured so that ammunition surveillance monitoring according to *FMV Handbok Ammunitionsovervakning (FMV H AmÖ)*^a is made possible.

a. FMV Handbook of Regulations for In-Service Surveillance of Ammunition, (not available in English)

2.3 REQUIREMENTS OF INTERNATIONAL LAW

The requirements for review with respect to international law are described in “The Ordinance on International Humanitarian Law for the Monitoring of Arms Projects” (Förordningen om folkrättslig granskning av vapenprojekt) SFS 2007:936, Chapter 7. The ordinance states that notification of weapons projects must be made to the “Delegation for international law review of weapons projects”. The requirement for notification applies to any project that concerns study, development, new acquisition or modification of weapons or combat methods.

The Swedish Government decided in 2007 on a review of the area and appointed the International Law Committee. It presented its work in the reports mentioned below. The reports provide the background to the requirements that apply in the area. Not least important is that the requirements are set in their historical context as many requirements are based on older international agreements:

- The interim report *The Laws of War* presents key documents on international law during armed conflict, neutrality, occupation and peace efforts (SOU 2010:22), including a list of humanitarian law treaties applicable to Sweden and their implementation in Sweden.
- The report *International law in armed conflict - Swedish interpretation and application* (SOU 2010:72).

The latest conventions, to which Sweden has acceded, which affect military equipment are:

- The Ottawa Treaty, or the Convention on the Prohibition of the Use, Stockpiling, Production and Transfer of Anti-Personnel Mines and on their Destruction,
- Convention on the Marking of Plastic Explosives for Detection Purposes,
- The Convention on Cluster Munitions, CCM.

2 Safety Activities and Requirements Common to all Equipment

In order to ensure compliance with international law, the following general requirements for weapons and ammunition are applicable. Special requirements relating to warheads are described in *Section 4.2.2* and the requirements for fuzing systems in *Section 4.4.2.6*.

- 1.203.001 A** Weapons and ammunition **shall not** be so designed that they violate applicable international law and conventions to which Sweden has acceded.
Comment: Thus, there is a ban on weapons that have an indiscriminate effect, that unnecessarily aggravate suffering or cause unnecessary damage.
- 1.203.002 A** Each project concerning study, development, new acquisition or modification of weaponry or methods of warfare **shall** be reported to the Delegation for Supervision of Weapon Projects.
Comment: Notification to the delegation must be carried out at an early stage and in cooperation with the Armed Forces.
- 1.203.003 A** Booby traps that look like civilian utility goods, or which are marked with internationally recognised safety symbols, **shall not** be developed.
- 1.203.004 A** Laser weapons mainly for use against people (anti-personnel laser weapons) **shall not** be developed.
- 1.203.005 A** Weapons intended to poison **shall not** be developed.
- 1.203.006 A** Incendiary weapons that have a non-discriminatory effect, or are mainly intended for anti-personnel use, **shall not** be developed.
- 1.203.007 A** Weapons that are difficult to aim at a specific target **shall not** be developed.
Comment: This requirement applies, among other things, to weapons used for carpet bombing.

- 1.203.008 A Weapons that may cause extensive, long-term, severe damage to the natural environment **shall not** be developed.
- 1.203.009 A High explosive shells designed primarily for anti-personnel purposes **shall** have a minimum weight of 400 grams.
- 1.203.010 A Mines **shall not** be designed to be of similar appearance to civil utility goods, neither may they be marked with internationally recognised safety symbols.
- 1.203.011 A Bullets **shall not** be easily expanded or flattened in the human body.
- 1.203.012 A Bullets **shall** have a full metal jacket and not have notches (compare dum-dum bullets).

See also text and requirements in *Section 4.4.2.6*.

2.4 SYSTEM SAFETY REQUIREMENTS IN OPERATIONAL REQUIREMENTS

The Armed Forces are responsible for formulating requirements on the system's capability, to specify the tolerable risk and enter this in the Operational Requirements (SMS) or equivalent document.

2.4.1 Application of civil requirements for weapons and ammunition

The regulations for system safety work describe a way of working where the basis is that the Armed Forces must comply with civilian work environment legislation. To handle equipment and situations where there are no civilian requirements or references, FMV has developed H VAS for the area of weapons and ammunition.

For cases where the Armed Forces use civilian products in the area of weapons and ammunition and where the use corresponds to civilian use, it is thus sufficient to show that civilian requirements are met.

However, an analysis of the user environment needs to be carried out to provide a basis for the assessment. Examples of areas where military requirements may need to be set are, for example, the electrical environment where the Armed Forces in many cases have systems that deviate from civilian norms.

In the next Section, examples are given of areas where civilian products can be used in the Armed Forces based on civilian requirements, but also examples of related products where military requirements are needed.

2.4.1.1 Civil explosives and detonators

Examples of this type of product are explosives, electric igniters and shock tube detonators. For this type of product, the civilian requirements for the products are sufficient even for the needs of the Armed Forces. Note the initial general requirements for analysis above.

2.4.1.2 Civilian maritime safety products

Examples of this type of product are emergency flares, emergency rockets and line throwers. For these, the civilian requirements are sufficient even for the needs of the Armed Forces. Note the initial general requirements for analysis above.

2.4.1.3 Small-calibre weapons

Certain types of firearms may not be legally marketed in the EU as they are prohibited by Council Directive 91/477/EEC (as amended by Directive 2008/51/EC), such as automatic weapons and certain military ammunition. There are thus different needs for safety work and standardization between military weapons and civilian weapons for hunting and shooting.

2.4.1.4 *Civilian small-calibre weapons and ammunition*

For civilian small-calibre weapons with ammunition, it is sufficient to apply civilian law. The basis for safety is the supplier's responsibility according to the Product Liability Act. In order to create common requirements and standards in the area, standardization bodies have been created, for example:

- Permanent International Commission (C.I.P.),
- Sporting Arms and Ammunition Manufacturers' Institute (SAAMI).

C.I.P. and SAAMI (see the following Section) work together to develop internationally recognized standards to achieve safety for users of sport and hunting firearms with associated ammunition. Even arms and ammunition manufacturers not operating in countries where C.I.P. or SAAMI are applied seem to follow their requirements, among other things, to be able to export to these markets.

Permanent International Commission for the Proof of Small Arms (C.I.P.)

C.I.P. is an organization with the majority of its members in Europe and headquartered in Belgium. C.I.P. includes a system of accredited test facilities within the organization that can certify that the requirements for weapons and ammunition have been met. The goal of C.I.P. is to achieve safety for users through standardized and certified weapons with associated ammunition and an open market (among Member States) for products that are C.I.P.-certified. Sweden is not a member of C.I.P.

Sporting Arms and Ammunition Manufacturer's Institute (SAAMI)

SAAMI is an organization for the standardization of weapons and ammunition based in the United States. The goal for SAAMI is to achieve safety for the users through standardized weapons with associated ammunition and an open market for products standardized by SAAMI.

2.4.1.5 *Military small-calibre weapons and ammunition*

For military small-calibre weapons with ammunition, a system safety work needs to be carried out. These weapons differ in terms of both requirements and user profiles from civilian weapons. Sweden has, through Partnership for Peace (PfP), interoperability goals and “host nation support” agreements, linked to many of NATO's standardization goals. NATO achieves interoperability and safety through NATO standards (STANAGs). NATO has a number of STANAGs for military weapons and ammunition. In addition to design standards, there are also NATO standards for control and verification, such as “MULTI-CALIBER MANUAL OF PROOF AND INSPECTION (M-CMOPI) FOR NATO SMALL ARMS AMMUNITION”.

2.5 DETERMINING REQUIREMENTS FOR THE REQUEST FOR PROPOSAL (RFP)

The purpose of the RFP is, based on the weapon and ammunition-related requirements in the Operational Requirements, to formulate the specific safety requirements that shall be included in the RFP.

System safety requirements are stated in the requirements specification which is enclosed with the RFP. The format of the requirements specification is defined by FMV's operational management system (VHL). In addition to the equipment specific safety requirements, further safety activities shall be stipulated, preferably as specified in the System Safety Handbook and other handbooks. Proposals from the supplier regarding the activities that should be included in the System Safety Program shall be stated in the SSPP, see *H SystSäk E*.

Examples of safety requirements:

- requirements list in accordance with H VAS E adapted to the procurement in question,
- criteria for qualification for the procurement of Insensitive Munition (IM),
- safety range for munitions,
- approved classes of laser (e.g. laser class as per IEC 60825-1, so-called eye-safe lasers).

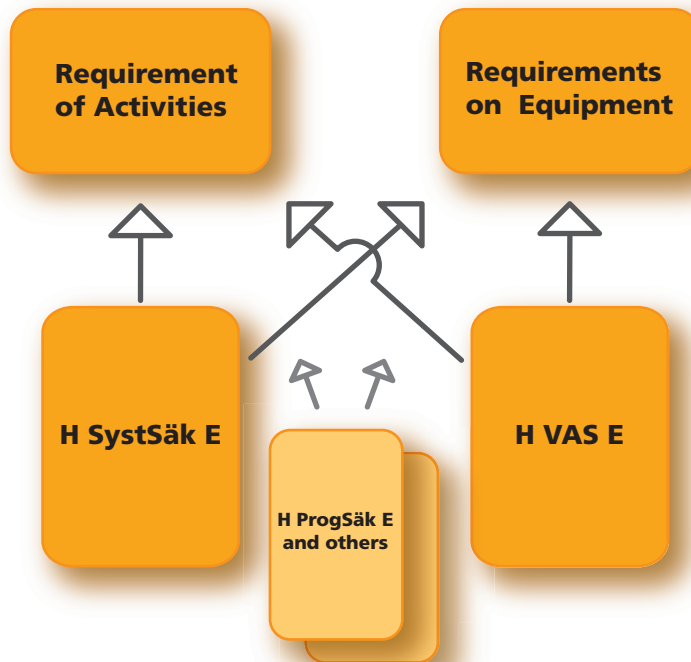

Figure 2:1 Allocation of requirements

2.6 INDEPENDENT REVIEW

The purpose is that a project shall receive independent advice from the advisory groups that have technical expertise and experience in weapons and ammunition.

Advice shall be obtained for projects involving the procurement or modification of weapons and ammunition. During the planning phase, resources should be allocated for this activity.

The following resources are available at FMV:

- The Advisory Group for Fuzing Systems (Rg T).
- The Advisory Group for Warheads and Propulsion Devices (Rg V&D).
- The Advisory Group for Explosives (Rg Expl).

Systems Review Manager for Ammunition safety (SystGL Amsäk) decides on staffing for the advisory groups.

Advice from Rg Expl is passed on to the Swedish Civil Contingencies Agency (Myndigheten för Samhällsskydd och Beredskap – MSB). Advice from Rg T and Rg V&D is authorised by SystGL Amsäk.

For advice regarding a project, SystGL Amsäk shall be consulted. If a case involves issues relating to both fuzing systems and warheads and/or propulsion systems, Rg T and Rg V&D can be merged to provide coordinated advice. If a case is simpler in nature, it can be decided only by the chairman and the secretary of the Advisory Group, and is referred to as a statement.

The standard method used when reviewing more complex systems is that fuzing systems are analysed first, and then the warhead and propulsion parts. After this the object is subject to a review by Rg Expl.

The ambition shall be to obtain advice as early as possible in the project. The gathering of advice can be conducted on several occasions during a project. Advice is generally given in response to any questions that have been asked and shall be used as support for a decision on further action regarding the project. In development projects, the advice can relate to various activities to ensure an acceptable level of safety; for the procurement of

COTS/MOTS, the advisory groups' evaluation can act as guidance with regard to the option chosen. FMV's role in the qualification of such products usually involves international co-operation, which means that an independent system review by the Advisory Group for Fuzing systems (Rg T) is difficult to implement in the early stages. The project should then be staffed by professionals who can deal with the technical issues that arise.

When requesting advice, the checklists in *Chapter 5* shall be followed.

For the Advisory Group's work to be meaningful, the group must have access to comprehensive, relevant information about the project/procurement in good time, at least three weeks in advance.

The independent review of weapons and ammunition within FMV is regulated by FMV's Internal Regulations ("Rules for ammunition safety activities within FMV").

2.6.1 Advisory Group for Fuzing systems (Rg T)

Advice shall be obtained for projects involving the procurement of weapons and ammunition. Records or statements from Rg T shall be communicated to Rg Expl as a basis for classification of explosives.

Rg T provides advice regarding the safety of fuzing systems with regard to

- fuzing systems for warheads,
- fuzing systems for propulsion systems,
- design and production methods for fuzing systems,
- compatibility.

The advice, among other things, may also relate to:

- proposals for action to be taken with existing fuzing systems and fuzing systems under development,
- proposals for project specifications and technical documentation.

The group shall monitor developments and communicate experience acquired concerning fuzing systems within FMV and to the authorities concerned as well as to companies.

The requirements specified in *section 4.4* constitute the basis for the Advisory Group's assessments.

- The project requesting advice shall submit a general description about the object regarding:
 - safety requirements, environmental requirements and the IM requirements that are specified in the Operational Requirements,
 - intended use,
 - weapon (or equivalent),
 - weapons platform,
 - ammunition,
 - danger zones.
- System/object shall be described with the help of:
 - drawings or diagrams,
 - wiring diagrams/block diagrams/printed circuit board layouts,
 - models or hardware,
 - safety critical software,
 - function of fuzing system,
 - arming conditions,
 - initiation conditions,
 - explosive trains/igniters (including characteristics),
 - safety devices.
- Statement describing materials and components:
 - type,
 - composition,
 - soldering methods, etc.,
 - treatment (e.g. surface treatment, heat treatment),
 - compatibility.

- Statement of compliance for *section 4.4* carried out in accordance with *chapter 5*.
- Statement describing safety verifications performed:
 - safety analyses,
 - environmental analyses,
 - tests.
- Review of the quality plan for the object.

A compiled and relevant documentation set shall be made available to the group at least three weeks before the review. In the event that newer documentation has been added prior to the review, deviations compared with previously submitted documentation shall be clearly traceable.

Communication with the group takes place via the e-mail address systemsakerhet.fmv@fmv.se with the heading “Rg Tändsystem”.

2.6.2 Advisory Group for Warheads and Propulsion Devices (Rg V&D)

The group shall provide the requested advice concerning the safety of launchers, propulsion devices and warheads regarding:

- structural strength,
- wear,
- material,
- design and production methods,
- compatibility.

Advice may also relate to:

- proposal for actions to be taken concerning existing weapons, launchers and warheads or suchlike that are undergoing development,
- proposals for project specifications and technical documentation.

The group shall monitor developments and communicate experience acquired concerning launchers, propulsion devices and warheads to FMV and the authorities concerned as well as to companies.

The projects presentation shall include the following:

- Concise, general information about the object:
 - safety requirements, environmental requirements and the IM requirements that are specified in Operational Requirements (SMS) or related document,
 - intended use,
 - weapon platform,
 - weapon (or equivalent).
- A detailed review of the launchers, propulsion devices, and warheads:
 - launchers and propulsion devices,
 - structural strength,
 - wear in launchers,
 - materials,
 - design and production methods for warheads and propulsion devices,
 - compatibility.
- Description of the safety analyses performed.
- Description of the safety testing, design type testing and other safety testing performed (as specified in FSD 0060 or equivalent).
- Compliance with requirements in *Section 4.2* and *4.3* carried out in accordance with *Chapter 5*.
- Proposed technical requirement specifications.
- Proposed quality plan for the object.

A compiled documentation set shall be made available to the group at least three weeks before the review. In the event that newer documentation has been added prior to the review, deviations compared with previously submitted documentation shall be clearly traceable.

Communication with the group takes place via the e-mail address systemsakerhet.fmv@fmv.se with the heading “Rg Verkans- & drivdelar”.

2.6.3 Advisory Group for Explosives (Rg Expl)

All equipment to be stored in the Armed Forces' explosives stores shall be reviewed by Rg Expl. This also applies to equipment without explosive content. Records or statements of opinion from Rg T and/or Rg V&D shall be communicated to Rg Expl as a basis for classification.

The group shall monitor developments and communicate experience acquired concerning explosives and their impact on safety to FMV and the authorities concerned as well as to companies.

The group submits documentation as a basis for decisions to be taken by the Swedish Civil Contingencies Agency (MSB) regarding the safety of explosives and can also make assessments and provide advice in the following areas:

- choice of explosives/explosive items,
- testing of explosives/explosive items,
- assessment of classification documents,
- classification of explosive items,
- production methods for the explosives/explosive items,
- compatibility.

The group can also provide advice regarding:

- proposals for actions to be taken with existing explosives and explosives undergoing development,
- proposals for project specifications and technical documentation.

Based on the project's documentation and presentation, the group proposes a UN classification and storage code (F-kod) for all ammunition and other explosives procured for the Armed Forces in accordance with the UN Recommendations on the Transport of Dangerous Goods, Manual of Test and Criteria (UN test manual) and IFTEX. MSB approves of and classifies the goods in accordance with the UN's recommendations, after which FMV decides and determines the storage code in consultation with MSB.

With regard to civilian standard small arms ammunition, see *H SystSäk*. When procuring explosives from a foreign supplier, approval by MSB shall be obtained before the product can enter Sweden.

When presenting a submission to Rg Expl (the Advisory Group for Explosives) concerning the recommendation of the storage code and the UN classification, all aspects that are of importance to transport and storage shall be highlighted.

The presentation shall include:

- general information,
- description,
- packaging,
- testing,
- documentation.

2.6.3.1 General information

Brief general information about the object relating to:

- safety requirements, environmental requirements and the IM requirements that are specified in Operational Requirements or related document,
- intended use,
- weapon platforms,
- weapon (or equivalent).

2.6.3.2 *Description of object*

The description of the object shall include the following:

- design (drawings, diagrams and possible model),
- function,
- data on all explosives, pyrotechnic compositions, and other active substances incorporated in the object. Weights and chemical compositions shall be stated and adequate designations shall be used, not brand names or similar. If new explosive substances are used, these shall be qualified in accordance with the UN test manual and with FSD 0214 or STANAG 4170,
- analyses performed concerning the compatibility of the various components incorporated within the explosives or pyrotechnic compositions, as well as the compatibility of the various explosives and pyrotechnic compositions with each other and with the surrounding material,
- fuzing system with safety devices and arming conditions (records and advice from previous reviews including an account of the risk for copper azide formation resulting from the presence of materials with copper content and lead azide),
- humidity protection,
- electrical screening.

2.6.3.3 *Packaging*

The following data shall be provided for packaging:

- design,
- location of the object in the packaging,
- total quantities of explosives,
- total weight,
- humidity protection,
- copy of type-approval certificate,
- proposal on labelling for transport and handling.

2.6.3.4 Testing

The testing of ammunition and other explosives is carried out as follows:

- Mandatory testing must always be performed as specified in FSD 0060 or an equivalent foreign standard (for example STANAG) and shall be presented, provided no comparison can be made with a similar object that has undergone such testing,
- All informative testing performed that can provide data concerning the sensitivity of the ammunition shall be presented, such as:
 - fragment impact,
 - small calibre bullet attack,
 - shock,
 - cook-off,
 - testing according to the UN test manual.

For applicable standards, see *Appendix 3*. Instead of the Swedish Defence Standard (FSD – Svensk Försvarsstandard), international standards may be applied, e.g. STANAG, MIL-STD or DEF-STAN.

Before classification in UN class 1.4S can be considered, adequate support data from tests conducted in accordance with test series 6 of the UN test manual must be available.

An alternative to testing to verify UN class 1.4S is available for fine-calibre ammunition. This is described in the above mentioned test manual. The test is based on calculating energy levels based on projectile mass and velocity. The method implies that the ammunition is initiated outside the chamber but with resistance.

2.6.3.5 Documentation

All documentation shall be made available to the group at least three weeks before the review. If newer documentation has been added prior to the review, deviations compared with previously submitted documentation shall be clearly traceable.

Communication with the group takes place via the e-mail address `systemsakerhet.fmv@fmv.se` with the heading “Rg Explosivämnen”.

2.7 SAFETY TESTING AND SAFETY ANALYSES

Safety testing and safety analyses are conducted to verify that the product’s safety requirements are met. Safety testing is a comprehensive and extensive activity, see *Figure 2:2*.

The purpose of safety testing can be divided into three areas:

- Safety testing is one of several methods used to verify that safety requirements are met (examples of other methods are analysis and inspection).

Example: 3-metre drop test to demonstrate robustness.

- Safety testing is a method of generating input data for the safety analyses that are used to verify other safety requirements.

Example: Testing to find out what happens with an incorrectly fitted spring in a fuzing system when the system falls from a truck platform, so-called FMEA testing.

- Safety testing is a method for providing the authorities with data for qualification/classification.

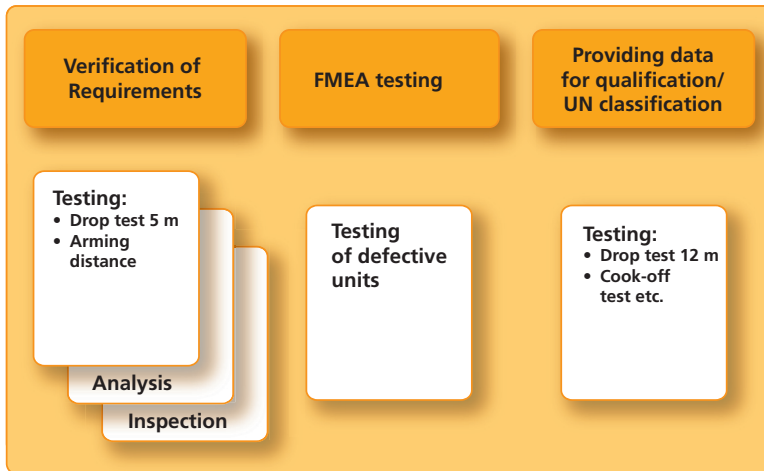

Example: Cook-off test and drop test 12 m to provide Rg Expl/MSB with data for UN classification and F-coding

Figure 2:2 Safety testing

As a complement to safety testing, safety analyses may be conducted to verify product safety requirements. There is a large number of analytical techniques aimed at different applications such as design solutions, operational handling and production processes. Each individual method has limitations which means that in many cases, it is appropriate to combine several methods to obtain a good result.

The choice of analysis method may be governed by a variety of factors, such as product design and function, how detailed the technical documentation is, which system level the analysis relates to, when (in the development phase) the analysis is carried out and how the safety requirements are verified.

H SystSäk outlines some examples of various safety analysis methods, including FMECA, FTA, ETA and HAZOP.

2.8 SAFETY SURVEILLANCE

Test instructions for safety surveillance form the basis of the surveillance of the ammunition in storage. Surveillance provides a continuous basis for assessment as to whether the ammunition continues to be safe to handle and store. Methodology and procedures for this are described in the *FMV Handbok Ammunitionsovervakning* (H AmÖ)¹.

2.9 TRAINING SAFETY REGULATIONS (TSR)

Training Safety Regulations relate to the development of support data for training and to all regulations that relate to handling in terms of development, storage, transportation, use, maintenance and disposal. Among other things, this includes the development of storage regulations that contribute to reducing the remaining risks of the weapon system to a tolerable level.

Draft instructions for transport, storage and handling shall be produced at an early stage in the materiel development process. Product development, which is carried out with representatives from the Armed Forces, shall aim to develop a product that meets the Armed Forces' requirements on performance and handling.

1. FMV Handbook of Regulations for In-Service Surveillance of Ammunition, (not available in English)

3 WEAPONS

In addition to weapons' safety, this chapter also includes safety in the interaction between weapons and ammunition. If any of the constituent parts are modified or developed further, or a completely new weapon system is developed or procured, interfaces must be carefully taken into consideration.

The purpose of this chapter is, among other things, to:

- identify what characteristics that should be considered and verified when developing and procuring a weapon system,
- identify what characteristics that should be considered during the development of ammunition,
- make proposals for the specification of interfaces between weapons and ammunition.

This chapter is subdivided into two main parts: The first part deals with the common requirements that apply to all weapon types, and the second part – called system requirements – also includes a number of non-specific requirements.

Requirements for warheads, propulsion systems, ignition systems and packaging specific to ammunitions can be found in *Chapter 4*.

Besides absence from malfunction in the weapon and ammunition, safety is also dependent on the interface between them and the interfaces between the system and the environment, and the application (use) for which it is intended. A specific type of weapon and a particular type of ammunition may be intended for different weapon platforms such as vehicles, airplanes and ships.

3 Weapons

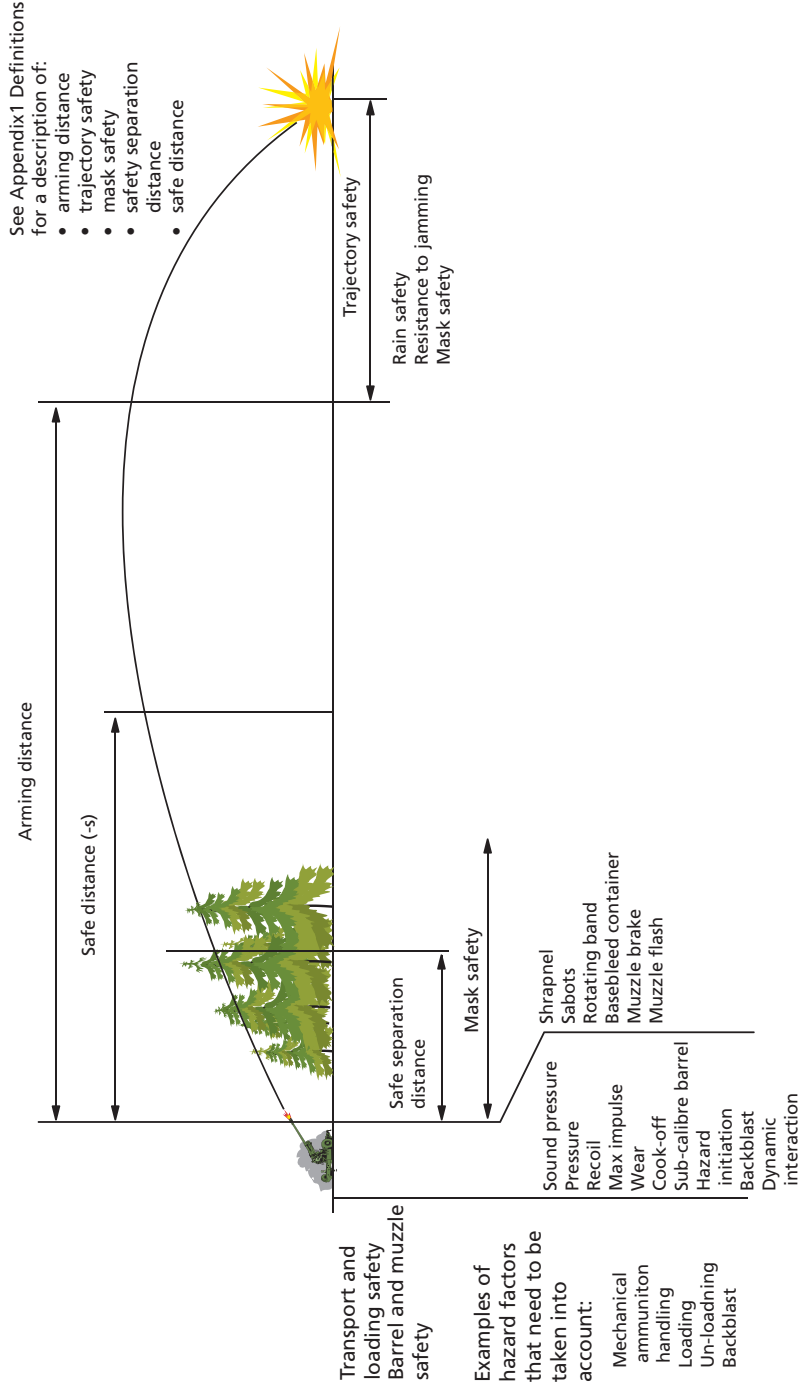

Figure 3:1 Overview of phases and risk factors

Figure 3:1 provides examples of the risks that may need to be evaluated for various types of weapons and in which phase damage/injury may arise. The figure does not claim to be exhaustive for all applications.

3.1 COMMON REQUIREMENTS RELATING TO WEAPONS

In this chapter, requirements that are independent of weapon type or are similar for several types of weapons are discussed. See also *Chapter 2*, for common requirements.

The handling of a weapon shall be acceptably safe both when it is separated from and mounted onto the weapon platform for all specified environments. This applies for training, exercise and for use in combat as well as with regard to maintenance.

The arming of the munition should take place at a safe distance from the weapon platform. When engaging a target at short range, this may come into conflict with the requirement to obtain effect in the target.

3.1.1 Danger area

When firing weapons and ammunition, the danger area must be calculated and closed off to prevent damage to property and injury to personnel. Sub-calibre anti-armour projectiles can travel over vast distances, guided ammunition, if a malfunction occurs, may deviate considerably from its intended flight path, etc. Even damage/injury caused by fragmentation, toxic gases, back blast and blast pressure must be taken into consideration.

Figure 3:2 shows an example of the danger areas around a weapon and around the impact area. The size of danger areas is affected among other things by the characteristics of the ammunition.

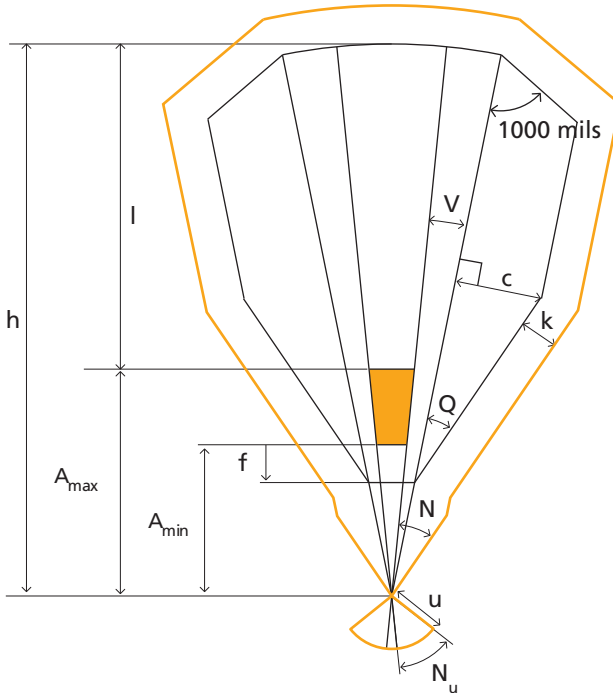

Figure 3:2 Example of danger areas

A full definition of the danger areas and how they are calculated is described in Säkr G, Armed Forces' safety instruction for weapons and ammunition etc. Common part.

1.301.001 T Based on analysis and testing, an assessment of the danger area for all current combinations of weapons, ammunition, and firing procedures **shall** be determined.

Comment: Refer also to the relevant hazard, e.g. blast pressure, fragmentation, toxic substances.

3.1.2 Safety of friendly forces

The proficiency required to operate the weapon, and the methods for the stowage of ammunition and other equipment, constitute a vital aspect of safety. In general terms, the risk of a major failure or accident owing to human error can be minimised by good ergonomic design and appropriate training.

Regarding safety in extreme climates, see *Section 3.1.5*.

- | | |
|--------------------|--|
| 1.301.002 T | There shall be an emergency stop function for laying and firing when the ordinary stop function is not sufficient to prevent injury to a person or damage to property.
<i>Comment:</i> Compare standard SS-EN ISO 13850:2008. |
| 1.301.003 T | The emergency stop function for laying and firing should be designed and operate in such a way that the energy source can be disconnected. |
| 1.301.004 T | The emergency stop function for laying and firing should be located as close to the energy source as possible. |
| 1.301.005 T | It shall be possible to unload a loaded weapon (the removal of the ammunition from the chamber, magazine and equivalent).
<i>Comment:</i> Some disposable weapons are not possible to unload. |
| 1.301.006 T | It should be possible to manually override automatic functions. |
| 1.301.007 T | It shall be possible for gun crews to wear specified equipment while at their operator station.
<i>Comment:</i> Such equipment may comprise personal protective clothing such as gloves, a helmet, eye protectors (e.g. protective mask, anti-laser goggles) and CRBN protective clothing. |

1.301.008 T	Monitors/VDUs should be designed to enable them to be viewed with existing lighting, even outdoors in direct sunlight or in darkness.
1.301.009 T	Symbols and texts on switches and other controls shall be legible and unambiguous in accordance with applicable standards.
1.301.010 T	In weapon systems where several operators can fire the weapon, it shall be possible for each operator to render the weapon safe independently.
1.301.011 T	Steps and footholds shall be fitted with appropriate anti-slip surfaces.
1.301.012 T	Locking devices shall be provided to ensure that heavier hatches and doors remain in the open position, see also requirements 1.303.023 T and 1.303.024 T.
1.301.013 T	Ventilation and heating/air conditioning systems should be incorporated if applicable.
1.301.014 T	A safe separation distance shall be established for all relevant types of ammunition in the most unfavourable firing conditions. <i>Comment:</i> Protective features on the weapon are to be taken into consideration, compare requirement 1.401.028 T.
1.301.015 T	The firing mechanism shall have a transport safety device.
1.301.016 T	Firing system shall have a safety device for the transport and operating phases.
1.301.017 T	It shall be possible to render the system safe to prevent inadvertent firing during loading/unloading and during transport of the system. <i>Comment:</i> For example, it must be possible to reassemble a transport safety device.

- 1.301.018 T The necessity of using a specific stance when firing a weapon **shall** be documented in the Safety Restrictions.
- 1.301.019 T When fitting external equipment onto the weapon, consideration **shall** be given to the effect of possible muzzle blast.
- 1.301.020 T Muzzle blast **shall not** cause injury to the gunner.
- 1.301.021 T The weapon should not produce such a muzzle blast that personal protective equipment is required for the crew.

3.1.3 Toxic substances

Substances produced by propelling charges during firing are considered to be dangerous to human health when their concentration in the air exceeds certain limit values. These substances include among other substances metals, ammonia, carbon monoxide and nitrous oxides. Propelling charge cases may emit dangerous chemical substances even after firing.

There may also be environmental risks if environmentally hazardous substances are spread during and after firing.

Carbon monoxide (CO) occurs in high concentrations when firing weapons and poses a danger since it is odourless and colourless, and blocks the blood cells' ability to bind oxygen. At high concentrations of carbon monoxide there is danger to life. Typical symptoms of carbon monoxide poisoning are headache, nausea, blurred vision, giddiness, extreme lethargy and unconsciousness. The bonding capability of carbon monoxide to the blood can be 300 times greater than that of oxygen. Carbon monoxide is removed solely through the lungs. The rate at which carbon monoxide is eliminated from the blood decreases exponentially and relatively slowly. The half-life time of carbon monoxide in the blood can be as high as four hours for a healthy person at rest in an environment free from contaminants.

3 Weapons

Ammonia (NH_3) is generated by the combustion of ammunition propellants. Exposure to ammonia primarily affects the respiratory tract and the eyes. At concentrations of 50-100 ppm, most people experience a moderate degree of eye, nose and throat irritation.

Nitrogen oxides, nitrous gases (NO_x) are generated primarily during firing. The predominant components are nitric oxide (NO) and nitrogen dioxide (NO_2).

The inhalation of nitrous gases can harm the lungs, which usually produce symptoms such as severe shortness of breath, but only after a half to one day. Fluid accumulation in the lungs (pulmonary oedema) can occur and deaths have been reported. The inhalation of a large amount of nitrous gases causes permanent lung damage.

Lead (Pb) and its associations can be absorbed into the body from inhaling finely atomized particles. Propelling charges and small calibre ammunition may contain certain quantities of lead. The lead is vaporised as the charge burns. Combustion gases containing lead either escape through the barrel or enter the crew compartment. Small particles of metallic lead appear when small calibre projectiles containing lead hit the target. Lead is a danger especially for pregnant women. This is when lead passes over to the foetus during pregnancy. Even at very low doses, lead causes damage to the nervous system, especially when the brain develops during the fetal period and early childhood. In adults, there are indications that lead exposure may affect the risk of high blood pressure and chronic kidney disease. Lead from ammunition can cause environmental impact.

Despite ventilation systems, dangerous gases and particles can be a major threat to personnel working in confined compartments, e.g. in combat vehicles. Hazardous chemical substances, even in small concentrations, can affect or degenerate personnel capacity.

A number of factors affect the level of concentration of hazardous chemical substances at the crew stations, such as:

- rate of fire and amount of fired ammunition,
- the chemical composition of the propellant,
- the efficiency of the fume extractor if fitted,
- the internal ballistics, nature and weight of the propelling charge,
- particularly risky materials used in the ammunition (e.g. beryllium alloys),
- the efficiency of ventilation systems, such as a CBRN ventilation system,
- leakage in the breech mechanism,
- the volume of the cartridge case,
- wind speed and direction,
- whether firing takes place with hatches open or closed,
- which weapons are fired,
- any overpressure in the crew compartment.

Note: The limit values are specified in AFS – Hygienic exposure limits.

1.301.022 T The concentration of hazardous substances, such as air pollutants, **shall** be lower than the permissible values stated in AFS – Hygienic limit values.

1.301.023 T Emissions during firing **shall** be documented.
Comment: The information provides a basis for assessing how users can be exposed to chemical substances and relates to the requirements in AFS – Hygienic limit values.

1.301.024 T Requirement *1.301.022 T* **shall** be verified for the worst possible firing conditions and at field conditions.

3.1.4 Electrical and magnetic fields

An electrical firing circuit may be subjected to radiated or conducted electrical interference generated by the weapon system in which it is incorporated, and to radiated interference generated by external sources, especially radio and radar transmitters. Firing and fuzing systems containing electric igniters may be particularly susceptible to such interference. Communication with the ammunition is also a sensitive function. Angle sensors, conditions for arming, and the control of status are other functions that can be affected and lead to a hazardous event. If the interference level exceeds the specified test level, there is a risk that inadvertent firing may occur.

Electrical switching operations within the weapon system may cause transient interference. On board radio transmitters and other electrical/electronic equipment may constitute an internal source of interference, particularly if electromagnetic screening is inadequate. External interference may emanate from airborne or ground-based radar and radio transmitters operating in the vicinity.

Special measures may need to be taken to protect the weapon system against electrostatic discharge (ESD), high-power microwave radiation (HPM), and against the electromagnetic pulse that arises in conjunction with lightning (LEMP) or when a nuclear charge detonates (NEMP).

1.301.025 T The susceptibility of electrical circuits to interference **shall** be analysed with regard to safety.

1.301.026 T The levels of electrical and magnetic fields to which the crew and equipment are subjected **shall** be determined.

See also *Section 3.2.3*.

3.1.5 Robustness to extreme climatic conditions

A system with its functions must be verified from a safety point of view for the climatic zones specified for the system. It is also necessary to verify that the crew can operate the weapon system in these conditions.

To ensure that a crew can fulfil its duties in the specified climatic zones the following requirements shall be met:

1.301.027 T Weapons **shall** be verified from a safety point of view for the climate zones stated in the specification for the system.

Comment: Stricter requirements normally apply to safety than to requirements specified for function. For data on climate, see NATO AECTP 230.

1.301.028 T The design of weapons and ammunition **shall** be formulated in a way that handling is possible also when operators are wearing protective clothing and using other equipment.

Water and moisture can affect mechanical, optical and electrical functions. Drainage of electrical and optical boxes, for example, is often necessary. Changes in temperature during storage can cause condensation on surfaces with a subsequent risk of moisture damage such as corrosion.

3.1.6 Fire

All constituent parts of a weapon system and types of munition may be subjected to fire owing to accidents or combat action. For this reason it is essential that the materiel is resistant to fire. Because of the various types of equipment, field of use, and variations in other circumstances at the time of fire, it is difficult to standardise a comprehensive fire test.

Any fire of a major scale generates temperatures in excess of 800 °C. Fire-resistant equipment must therefore resist such a temperature for a certain prescribed time without inadvertent initiation of propelling charges or warheads, and in some cases the

3 Weapons

equipment shall remain operational after the specified fire exposure time. Even with fires at lower temperatures, large quantities of toxic gases can be produced.

Fire tests can be subdivided and defined as follows:

- material tests to determine the properties of certain materials when exposed to fire,
- system tests which often consist of operational tests in which the weapon system or ammunition are subjected to a fire scenario specified by the authorities,
- safety tests to determine the characteristics of the weapon and ammunition when exposed to fire or an explosive atmosphere from the point of view of the crew and materiel safety. The following characteristics are pertinent:
 - resistance to fire with retained function,
 - the risk for explosion or ignition during fire,
 - the occurrence of toxic or corrosive gases during fire,
 - hazards in an explosive atmosphere.

For information concerning fire-fighting refer to *Section 3.4.3, Fire-fighting equipment*.

Additional requirements concerning the resistance of ammunition to fire are stated in *Chapter 4*.

The requirements shall ensure the safety of the crew during fire in the weapon or ammunition as well as during fire in the crew compartments and ammunition stowage compartment.

Testing can be performed as specified in FSD 0165 or STANAG 4240.

1.301.029 T In the event of fire in a weapon platform or in equipment (ammunition or other) stowed in a confined space the crew should be protected by specific design measures and/or escape routes.

3.1.7 Sound pressure

When firing a weapon, harmful impulse noise occurs. Depending on the individual's sensitivity, exposure to a shot may be sufficient for hearing loss to occur if hearing protection is not used.

To minimize the risk of hearing damage, measurements of the sound pressure level must be performed. These measurements shall be carried out in accordance with the Swedish Armed Forces' measurement methods for impulse noise, FM2019-25521: 1, 2019-12-05 or later editions of this letter. The results from the measurements form the basis for what personal protective equipment is required, which is regulated in the Armed Forces' internal regulations on impulse noise, FIB 2019: 4. In some cases where the impulse peak value is very high, the calculation of the number of permitted shots must also be carried out, in accordance with this ordinance.

Regarding the acquisition of new technical systems and when modifying existing systems, the Design Rule Requirements for sound levels and sound quality in technical systems, 14FMV10020-65:1, 2018-12-06, contains the goals and requirements to be applied, and to be dimensioning, for e.g. peak impulse sound levels for weapons.

1.301.030 T The sound pressure level **shall** be determined for the personnel concerned. Measurements **shall** be carried out in accordance with the Armed Forces' regulations for the measurement of impulse noise from weapons and blasting in open areas as well as in built-up areas in accordance with Armed Forces' regulations. The results of measurements form the basis for the type of personal protective equipment required and the number of exposures (rounds) the crew concerned may be subjected to over a specified period of time.

Comment: Regulations in accordance with HKV document ref. FM2019-25521:1 dated 2019-12-05 or equivalent replacements. The Swedish Armed Forces is conducting continuous work in this area; regulations will therefore most probably be updated. On this basis, checks have to be made to ensure that current regulations are applied. Proposals for requirements for the acquisition of new technical systems and for modification of existing systems are stated in the design rule "Requirements for sound levels and sound quality in technical systems", 14FMV10020-65: 1, 2018-12-06.

1.301.031 T The use of protective devices and the location of the crew relative to the launcher **shall** be stated in the Safety Instructions.

3.1.8 Back blast

Back blast is the rearward flow of (hot) propulsion gases which, when a weapon is fired, escape from the muzzle brake of recoil weapons and from the rear opening of recoilless weapons. The blast may contain fragments and particles swept up from the ground.

1.301.032 T The back blast (propellant gases and unexpended gunpowder) from the muzzle brake or equivalent via the rear opening during firing **shall not** have such high particle and energy content that it can cause injury to personnel or damage to equipment outside the specified danger area.

1.301.033 T Requirement *1.301.032 T* **shall** be verified by calculation and testing.

3.1.9 Vibration dose

During firing each individual crew member is subjected to a vibration dose. By establishing a vibration dose value (VDV), a limit can be set for each individual crew member.

VDV is a measurement of the total level of vibration to which a crew member may be exposed during a specific period of time. The value gives a general indication of the associated discomfort and risk of injury. VDV is calculated from data obtained from trials. From these results the number of rounds that may be fired before the VDV level is reached is calculated for various angles of elevation and traverse.

1.301.034 T Personnel **shall not** be exposed to a harmful vibration dose.

Comment: Commonly used requirements for exposure to body vibration are stated in AFS 2005:15.

3.1.10 Pressure

When projectiles are fired, the launcher and projectile are subjected to an internal ballistic gas pressure. If this pressure in any part of the barrel exceeds its permitted level, there is a risk that the barrel may deform or rupture and cause serious injury or death. During the design phase it must also be ensured that other components than the barrel that are subjected to pressure, such as the breech block, mechanism and projectile, can also withstand the loads involved. If inner-ballistic gas pressure exceeds the projectile's permissible pressure level, there is a risk of inadvertent detonation; the projectile must therefore be able to withstand this pressure.

1.301.035 T When establishing the dimensions and design of the barrel, breech mechanism and other parts exposed to pressure, the pressure definitions and procedures stated in STANAG 4110 or equivalent standard **shall** be applied.

3.1.11 Spring forces

This section contains guidelines for forces in springs, which in the event of a failure/malfunction can be released and cause injury (e.g. from impact and/or crush injuries by moving parts). Risks occur most often during overhaul, maintenance and disposal.

1.301.036 T It **shall** be possible to determine whether a spring contains stored energy.

Many designs contain spring forces; such as:

- ram springs in loading trays,
- loading springs in ammunition magazines,
- brake parts (like parking brakes, etc),
- balance springs,
- operating springs in breech mechanisms.

During recoil motion in a recoiling system, springs for the ramming motion of the loading tray, for example, can be cocked. The energy stored constitutes a hazard which, when inadvertently released, can result in death or serious injury.

It is important that the analysis gives special consideration to the status of springs incorporated with regard to stored energy in the event that firing is interrupted.

Springs in a breech mechanism shall be given particular consideration during the safety analysis, since failure modes in these design elements can have critical consequences.

When the attachment elements of a spring may constitute a more frequent hazard than the spring itself, such attachment elements shall be integrated into the safety analysis.

1.301.037 T Spring forces that alone, or in combination with other hazards, can result in an accident **shall** be analysed.

1.301.038 T Spring forces that can cause an accident **shall** either be provided with double locking devices or protective covers that prevent inadvertent release of the spring forces.

1.301.039 T Any spring that constitutes a component in a locking device which, in the event of malfunction, can cause injury, **shall** be analysed with regard to failure modes and characterised.

1.301.040 T Fastening elements **shall** be analysed with regard to failure modes and characterised together with the spring.

1.301.041 T The characteristics, according to requirements *1.301.039 T* and *1.301.040 T*, **shall** be maintained between inspection intervals for preventive maintenance purposes, so that safety is not impaired.

1.301.042 T Springs and their attachment elements that can affect safety **shall** be protected so that inadvertent contact by personnel or the environment around the system does not degrade their safety.

1.301.043 T Springs and their attachment elements that can cause a serious injury in the event of malfunction should have a duplicate (redundant) function or have a fail-safe function.

3.1.12 Hydraulic and pneumatic forces

This section contains guidelines for forces in hydraulic and pneumatic designs, which in the event of a failure/malfunction can be released and cause injury (e.g. from impact and/or crushing by moving parts). Risks occur most often during overhaul, maintenance and disposal.

1.301.044 T It **shall** be possible to determine whether a hydraulic or pneumatic design contains stored energy.

Hydraulic pressure (and also pneumatic pressure) during operation, or accumulated hydraulic pressure after operation, can result in hazardous events. Hydraulic pressure can also constitute a hazard via its connected equipment (hydraulic cylinders, motors, hoses, etc).

1.301.045 T Accumulated pressure **shall** be monitored and equipped with a device for pressure equalisation if inadvertent actuation in the system can lead to injury during operation, unloading and/or maintenance.

1.301.046 T Monitoring as specified in requirement *1.301.045 T* should be duplicated (instrument and control lamp) or have a fail-safe function.

1.301.047 T Hydraulic hoses and components should be located outside confined crew compartments.

1.301.048 T Hydraulic fluid should be prevented from penetrating into crew compartments.

3.1.13 Recoil forces

Recoil forces exist both in recoilless and recoiling systems.

Recoilless systems are found, among other things, as shoulder-launched anti-armour weapons such as rocket-propelled grenade launchers and recoilless anti-tank weapons. In recoilless systems the recoil is almost neutralised by the gas flow through the open rear end of the barrel which is equipped with a nozzle. There is no absolutely recoilless system. Instead, the recoil is generally so small that it does not entail any potential hazards.

1.301.049 T The danger area around recoiling and recoilless systems **shall** be determined and specified in the Safety Instructions (SI).

Comment: The actions of the gun crew in all situations (emergency firing, unloading, etc.) are to be considered.

1.301.050 T If overpressure can occur in the recoil brake and recuperator hence constituting a hazard, they **shall** be equipped with a device for relieving the pressure before disassembly.

1.301.051 T The recoil forces in a recoilless system **shall** be determined by calculation and testing.

3.1.14 Other forces

Some examples of parts in a weapon system that can cause serious injuries are:

- loading trays,
- empty cartridges,
- axles/shafts and other rotating parts.

1.301.052 T Rotating and other moving parts should be located so as to minimise the risk of injury.
Comment: This requirement can be satisfied by the provision of safety guards or by preventing the presence of personnel inside the danger area.

1.301.053 T It **shall not** be possible for loading devices to be controlled by anyone other than the person performing the loading.

1.301.054 T Crew **shall** be protected against the ejection of empty cartridge cases.

3.1.15 Lasers

A laser emits electromagnetic radiation. The radiation is generated by means of controlled stimulated emission, which gives the laser radiation special characteristics. The radiation from a laser is located within a narrow waveband.

Laser radiation generally has a very small divergence, i.e. the individual beams are practically parallel. Since the laser radiation can also be very powerful, the radiation density (power/unit area) is high even at great distances.

Laser radiation is rectilinear and has the speed of light, about 300,000 km/s. Lasers emit radiation continuously, in pulse trains or as single pulses.

Laser radiation can primarily damage eyes and skin, mainly because of the heat produced. The eye is most sensitive to exposure. In the UV range, damage may affect the cornea and the lens. In the wavelength range 380–1400 nm, laser radiation passes through the eye (cornea and lens) and focuses on a point on the retina (in the wavelength range 1200–1400 nm the cornea and the lens may also be damaged). This may give rise to different forms of eye injuries and risks, ranging from being dazzled to permanent burns and blindness. Burns on the skin can occur when exposure takes place at close range to the laser. There is also a risk of ignition of clothing, fuel, ammunition etc.

Binoculars and magnifying optics have the property of focusing rays directed towards them and can therefore cause injury or worsen an injury to an unprotected eye. It is the size of the aperture and the instrument's magnification that determines how much the eye is exposed.

If magnifying optics is used, risk distances increase roughly equal to the instrument's magnification. If a powerful laser is used to point out targets during bombing, reflections from shiny objects such as metal surfaces, glass sheets, water surfaces and wet leaves can also pose a risk of eye damage.

The provisions of H VAS on the use of lasers are applications of general regulations and standards for lasers according to:

- AFS 2009:7 Artificial optical radiation (with current updates, including AFS 2014: 8),
- SSMFS 2014:04 The Swedish Radiation Safety Authority's regulations on lasers, strong laser pointers and intensely pulsed light,
- SS-EN 60825-1 edition 5, 2014 Laser - Safety - Part 1: Classification of equipment and receivables.

See also the Swedish Armed Forces' Regulations for Operational Safety - Joint, SäkR G (M7739-353144).

1.301.055 T The laser should be equipped with a device to ensure that it is not activated in unintentional high power mode, as the power of the laser is so high that it is justified.

1.301.056 T It should be possible to equip high power lasers with optical attenuators.

1.301.057 T Lasers with higher class than laser class 1 shall be equipped with warning sign.
Comment: For lasers with physical dimensions that make marking with a warning sign impossible, the warning text must be presented in the instruction manual and marking must be done on the laser's packaging.

1.301.058 T Sights, prism windows etc. should either have built-in laser protection filters or be designed in such a way that it allows the operators to wear laser safety goggles.

1.301.059 T New lasers shall be delivered with a classification certificate.
Comment: The classification is based on requirements from AFS 2009:7 with current updates and SSMFS 2014:04. Competence that ensures that classification is carried out can be found within FMV.

3.1.16 Mechanical stability

The stability of a weapon system during firing is affected e.g. by the following main factors:

- trunnion forces and height above the trunnion,
- the angle of elevation,
- the weight of the weapon system and the location of its centre of gravity,
- the longitudinal axis of the weapon system relative to the direction of fire,
- the incline and type of ground surface,
- the effectiveness of brakes and suspension,
- the presence of outriggers.

Stability during firing must be verified. The safety of the crew must also be analysed.

1.301.060 T The stability of the chassis, platform, controls, eye-piece, launcher etc. **shall** be such that there is adequate stability during firing.

1.301.061 T It **shall** be possible to secure doors and hatches in the closed and open position.

1.301.062 T Weapons/weapon platforms **shall** be designed so that stowed equipment and ammunition cannot move or be dislodged from their designated places during use.

Comment: Requirements regarding resistance to mine shock are to be taken into account.

3.1.17 Transport

Logistical and tactical transport has an impact on weapons and munitions in a way that can change their properties and therefore safety. For instance, ammunition deteriorates if it is carried in combat vehicles over a long period of time and/or over long driving distances so that it is no longer safe to use. This risk can arise, among other things, due to mechanical changes to the propellants. To form a basis for requirements, transport conditions shall be analysed.

In addition to the weapons and ammunition which belong to the vehicle's/vessel's/aircraft's weapon system, other weapons and ammunitions may be being transported.

Transport robustness testing should be performed whenever:

- new systems are developed/purchased,
- new ammunition is introduced into an existing weapon system,
- ammunition storage has been altered,
- the vehicle is equipped with tyres, tracks or a suspension system that is/are new or of a different type,
- the vehicle is used in a new environment involving different environmental stresses for the ammunition.

1.301.063 T Racks and bins **shall** be designed so that the environmental impact during transport and movement **shall not** exceed the specified robustness of the ammunition.

3.2 FIREARMS, CANNONS AND MISSILE LAUNCHERS

Most modern weapons of large calibre have hydro-pneumatic or hydro-mechanical mechanisms to assimilate recoil forces and to return the system to its initial position (“run-out”). Rifled guns also generate a torque acting on the gun when spin is imparted to the projectile. Many weapon systems have a muzzle brake fitted to the barrel to reduce the recoil force.

For any given design of a weapon and type of ammunition, the forces acting on the system vary according to angle of elevation, the temperature of the propellant and the temperature of the recoil system. Large calibre weapons that have semi-automatic breech mechanisms can utilize the recoil energy to open the breech on run-out. *Section 3.2.1–3.2.7* specify requirements on launchers for various recoiling weapon systems. *Section 3.2.18* presents specific requirements on launchers for recoilless weapon systems and rocket systems.

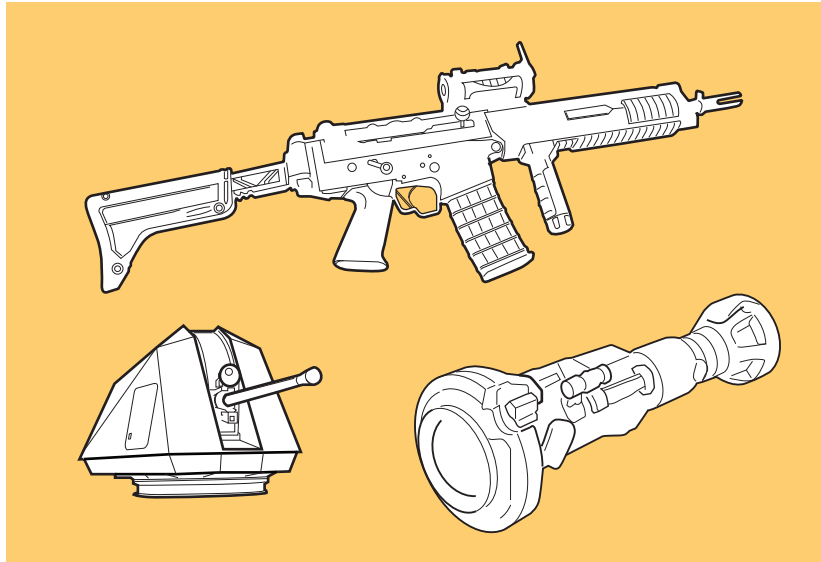

Figure 3:3 Examples of launchers

3.2.1 Weapon installation

During development it is necessary to verify the structural strength and integrity of the weapon installation. Verification can be performed by means of calculation and/or testing.

1.302.001 T Launchers controlled by electronics systems **shall** meet the requirements that apply to electronics and software-controlled subsystems in *Section 4.4.5* and in accordance with relevant requirements in *H ProgSäk*.

Comment: See also the requirements for ignition systems for propulsion devices in *Section 4.4.8.9*.

1.302.002 T Clearance between the elevating system and other parts at maximum recoil within the entire laying range in traverse and elevation **shall** be sufficient to prevent damage to the system.

1.302.003 T Protective barriers and covers should be fitted to prevent crew members from being injured by moving system parts (i.e. within the range of movement of the recoil system, etc).

Comment: “Dangerous area” is to be marked.

3.2.2 Breech mechanisms

There are several types of breech mechanisms such as screw type with interrupted threads, a wedge-shaped transverse block (breech block) and a bolt.

1.302.004 T It **shall** be possible to operate the breech mechanism from outside the zone of motion of the recoil system to prevent injury to crew members by squeezing.

1.302.005 T When the breech mechanism is fully closed it **shall** be locked in its position.

1.302.006 T The breech mechanism **shall not** open as a result of vibration caused by firing or motion/transport.

- 1.302.007 T It should not be possible to assemble any component of the breech mechanism in an incorrect manner that could cause injury/damage or lead to an unsafe condition.
- 1.302.008 T When the breech mechanism is operated automatically the firing mechanism **shall** automatically become inactive before the breech mechanism is released from its locked position.
- 1.302.009 T It **shall** be possible to indicate or observe the status of the breech mechanism.
- 1.302.010 T It **shall not** be possible to fire the weapon if the breech mechanism is not fully closed.

3.2.3 Firing mechanism

The firing mechanism initiates the propelling charge via an ignition system with a primer. This is either an integrated part of a cartridge case, or a separate system. The breech mechanism is the device by which the firing of the gun is controlled and it is therefore of great importance so that the weapon is not fired inadvertently.

The firing system can be mechanical or electrical:

- Mechanical (with a striker). In this type, a metal firing pin strikes the detonator on the primer causing it to produce a flash which ignites the propelling charge. The firing pin is actuated by the release of a spring mechanism, either manually or by a mechanical or electrical device.
- Electrical. For this type, the primer is electrically initialised.

1.302.011 T It **shall** be possible to make the firing mechanism safe from outside the zone of motion of the recoil system.

1.302.012 T The weapon **shall** be fired by an active operation from outside the zone of motion of the recoil system.

- 1.302.013 T If an electromechanical device is used it **shall** be protected from radiated or conducted interference that could cause unintentional firing of the system.
- 1.302.014 T If firing button, pedal, lever or similar device is employed it **shall** be provided with protection against inadvertent operation such as by a trigger guard.
- 1.302.015 T Electrical firing systems **shall not** be susceptible to radiated or conducted interference generated by other electrical installations within the weapon system, or from external sources of interference (radio, radar etc.) that could result in inadvertent firing of the system.
- 1.302.016 T The firing system should be designed in such a way that the electrical connector does not make contact with the base connector of the artillery primer until intended firing.
- 1.302.017 T There should be at least one mechanical safety device that directly prevents the striker from actuating. This feature should not be a part of the firing linkage.
- 1.302.018 T There **shall** be a separate manually operated safety switch that breaks the electrical firing circuit.
- 1.302.019 T The safety switch specified in requirement *1.302.018 T* **shall** be located outside the zone of operation of the recoil system.
- 1.302.020 T The safety switch specified in requirement *1.302.018 T* **shall** be marked with actual position/mode such as: S for safe, P for single round, and A for automatic fire.

3.2.4 Breech ring

The breech is one of the parts in a firing system that is subjected to very high stresses. In the same way as the barrel etc. can become fatigued, so too can the breech. The safety analysis of the breech is based on calculations and testing.

1.302.021 T For a given load profile, the life of the breech ring **shall** be established by calculation and material testing.

3.2.5 Obturation

The breech mechanism shall prevent leakage of propellant gases. The choice of obturation system is dependent on design requirements such as rate of fire and the size of ammunition. From a safety point of view, the obturation system must function with all types of relevant charges over the entire temperature range.

Leakage of hot propellant gases could severely burn members of the crew. A minor leakage could cause a rise in the concentration of toxic fumes, especially in confined spaces. It should be noted that initiation systems employing an igniter also necessitate a gas-tight solution. The same requirement should apply to any future initiation system such as laser ignition or an equivalent system.

1.302.022 T Obturation **shall** be designed to ensure that the crew is not exposed to either hot gases or harmful concentrations of toxic fumes.

3.2.6 Secondary combustion

Secondary combustion sometimes occurs in recoiling systems when the breech is opened after firing. It occurs when combustion has not been completed or when combustible propellant gases are released and are ignited by the supply of oxygen when the mechanism opens. The resultant flash can cause burns to crew members and constitutes a hazard for propellant charges and equipment for example inside a combat vehicle.

An ineffective fume evacuator may be an influencing factor. Secondary combustion is not always detected during development trials of the propelling charge since the breech is not always opened immediately after firing in such trials. Trials should be performed to determine whether there is a problem. If the problem is serious, restrictions may have to be placed on the use of certain charges. Alternatively, other measures may have to be taken such as the introduction or modification of fume evacuator evacuation by compressed air.

1.302.023 T Secondary combustion, which may cause injury to personnel, **shall not** occur.

3.2.7 Barrel wear

Barrel wear is primarily caused by hot propellant gases eroding the inside of the barrel. Normally barrel wear is defined as the increase in bore diameter at a specific point in the barrel (usually at the start of the rifling). Wear reduces the efficiency of obturation since it allows hot gases to pass the projectile. This leakage of hot gases can accelerate barrel wear. As wear increases, the hot gases may begin to erode material from the driving band of the projectile. Eventually a level of wear is reached that results in insufficient spin being imparted to the projectile. The resultant instability of the projectile then constitutes a hazard, both in the barrel and in the trajectory. Wear increases when firing at a high muzzle velocity and at a high rate of fire.

In a worn barrel the projectile may accelerate ‘unguided’ until it engages with the rifling. The resultant load may then cause the driving band to be damaged while in the barrel. A worn barrel is normally defined as a barrel that has less than 25% left of its total service life.

1.302.024 T The barrel **shall not** constitute an increased risk (such as by imparting extra stress on ammunition or incorrect trajectory) when the ammunition in question is fired in either a new or worn barrel.

Comment: A barrel is defined as worn when it has less than 25% left of its total service life.

1.302.025 T Requirement *1.302.024 T* **shall** be verified by testing.

3.2.8 Barrel fatigue

In most modern weapon systems the use of surface coated barrels, wear reducing material (such as titanium dioxide), and non-metallic obturating material has decreased the rate of barrel wear and has thus extended barrel life considerably. Consequently, metal fatigue rather than wear can be the determining factor when calculating the service life of a barrel as fatigue failure may occur before wear life has expired. To determine fatigue life, it is necessary to perform theoretical calculations. Fatigue life shall be determined to avoid fatigue failure with possible ensuing barrel rupture.

1.302.026 T Fatigue life span **shall** be determined and verified. Theoretical calculations may be used.

Comment: See STANAG 4516 and STANAG 4517.

3.2.9 Barrel rupture

Under extreme and undesirable conditions, such as when soil, sand or snow has accumulated in the barrel, barrel rupture may occur. Ammunition, sabots, obturators, jackets, etc. can also cause fragmentation during firing. To ensure the safety of the crew, the requirements below shall be satisfied.

1.302.027 T The barrel **shall not** rupture when firing with a specified amount of snow, sand or gravel in the barrel.

1.302.028 T Requirement *1.302.027 T* should be verified by testing.

Comment: The requirement applies primarily to small-calibre weapons but if the system is used in such a way that there is a high probability that foreign matter may enter the barrel it may also apply to larger calibre weapons. Testing is performed by filling the barrel with various quantities of sand and gravel to determine the durability of the weapon.

3.2.10 Cook-off

Where barrel cooling systems are not employed, a sustained high rate of fire will make the barrel extremely hot. Hazard initiation of ammunition (“cook-off”) can occur in a hot barrel when, for example, firing is interrupted while a round is rammed. Usually it is the propelling charge that is initiated, but initiation of the warhead can also occur. It is also conceivable that a projectile detaches from the cartridge case during ramming thus enabling propellant to come into direct contact with the hot surface of the barrel with the risk of hazard initiation.

When a warhead heated in this way is ‘fired’, melted explosive may be subject to hazard initiation caused by the acceleration stresses generated during firing.

1.302.029 T Cook-off **shall not** occur during the maximum specified fire engagement in combination with jamming involving rammed ammunition.

Comment: Refer also to requirements 1.401.020 T, 1.402.011 T and 1.403.019 T.

1.302.030 T To determine the risk of cook-off, the temperature and heat flux etc. for a hot barrel **shall** be established.

Comment: The Safety Restrictions must state the permitted rate of fire, the permitted number of rounds per salvo, and/or the permitted duration for fire. If different types of ammunition are used in the weapon, this should be taken into account in the test. Refer also to requirement 1.401.019 T.

Testing and calculations are necessary to determine at what temperature cook-off occurs, as well as how many rounds and which rate of fire are necessary to attain this temperature.

3.2.11 Fume evacuators

A fume extractor is a cylinder attached around the mid-section of the barrel. It is pressurized by the propellant gases produced during firing and vents them forwards in the barrel, thereby extracting residual gases through the muzzle. The fume extractor also helps to prevent the occurrence of secondary combustion. The fume extractor is subjected to a certain load during firing, and must be designed to withstand such stresses.

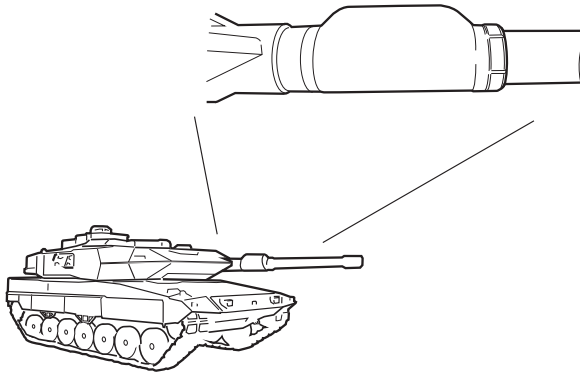

Figure 3:4 Example of a fume evacuator

3.2.12 Muzzle brakes, flame guards and recoil amplifiers

Weapon systems are provided with muzzle brakes to reduce recoil forces. The muzzle brake is subjected to great forces by the high gas velocity, high velocity particles and high pressure.

In some cases it may, however, be necessary to increase recoil forces because of functional requirements (applies to automatic weapons). This can be achieved by mounting a recoil amplifier (expansion nozzle/funnel) on the muzzle.

Flame guards are employed to reduce the signature from the weapon when firing.

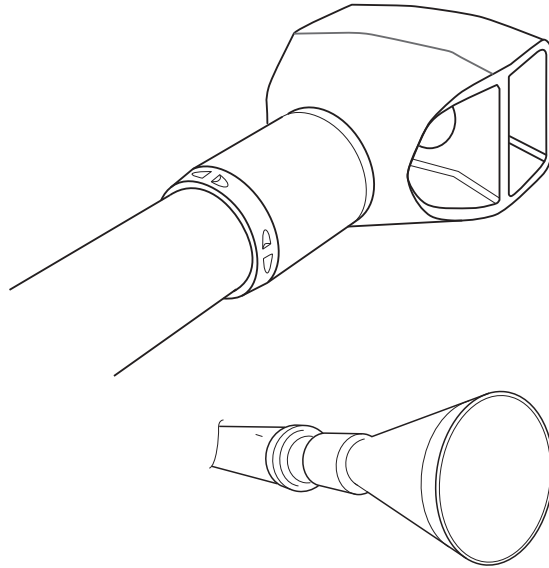

Figure 3:5 Examples of muzzle brake (top) and recoil amplifier (bottom)

1.302.031 T The muzzle brake should prevent rearward ricochets of driving bands, sabots, obturators, etc.

1.302.032 T During modification in the design, or new development, of ammunition or weapons relating to driving bands, sabots, obturators, jackets etc., or in the event of changed rifling pitch in the barrel or a new muzzle brake, testing **shall** be performed to determine the occurrence of fragmentation.

3.2.13 Muzzle flash

Muzzle flash occurs when the projectile passes the muzzle and unburnt propellant gases are combusted. Besides danger to the crew, muzzle flash may also damage sight equipment (image amplifiers/night vision equipment).

1.302.033 T When fitting external equipment onto the weapon or weapon platform, consideration **shall** be given to the effect of possible muzzle flash.

3.2.14 Sub-calibre barrels

Sub-calibre barrels or sub-calibre adapters are often used to provide an opportunity to take advantage of cheaper ammunition for training and practice purposes. By using a sub-calibre barrel, the weapon system can largely be operated in a regular way and effective training can be achieved.

1.302.034 T Applicable requirements stated in *Section 3.2.7–3.2.10* above **shall** apply.

1.302.035 T It **shall not** be possible for a correctly fitted sub-calibre barrel to detach during firing.

1.302.036 T It **shall** be possible to inspect a sub-calibre barrel for cracks and other defects.

1.302.037 T Sub-calibre barrels **shall not** produce different levels of stress on ammunition, if the barrel length of the practice weapon differs from its original design.

Comment: If, for example, a sub-calibre barrel is longer than a standard barrel, other acceleration and spin stresses may arise. It must be determined whether the ammunition is designed for such stresses.

1.302.038 T Requirements *1.302.035 T* and *1.302.037 T* **shall** be verified by test firing using the actual propelling charges and types of ammunition.

3.2.15 Ramming

Ammunition can be rammed into the barrel in a number of different ways. When a high ramming velocity is used, such as with a high rate of fire, the high explosive or fuzing system in the projectile may be damaged. Ammunition containing submunitions, electronics, or rocket motors may be particularly vulnerable in this respect.

- | | |
|-------------|---|
| 1.302.039 T | The rammer should be provided with safety devices that prevent injury to personnel. |
| 1.302.040 T | The ramming environment for the weapon in question shall be verified by testing. Testing shall also be performed at the extreme temperatures that are specified as a basis for the requirements of the ammunition.
<i>Comment:</i> Compare requirement 1.404.037 T. |
| 1.302.041 T | During driving in terrain in accordance with specified conditions, the ammunition should not fall back from the rammed position.
<i>Comment:</i> This requirement should be verified by testing with a barrel that has 50% or less of its service life remaining in terms of wear. |
| 1.302.042 T | The system should withstand rounds being fired with ammunition that is not rammed in a correct manner (i.e. in fall-back position).
<i>Comment:</i> Gas leakage around the ammunition can damage both the ammunition and the barrel. Compare requirement 1.401.015 T. |

3.2.16 Recoil brakes

Recoil brakes/buffers are used to absorb or reduce the kinetic energy of the recoiling system. The recoil forces are usually dampened with devices such as mechanical springs, recoil liquid, or pressure vessels (gas). The system contains substantial forces which is why care must be taken during maintenance, repair, and demilitarization.

Before, during, and after firing, the following requirements shall be satisfied:

- | | |
|--------------------|---|
| 1.302.043 T | The system shall be designed so that the static pressure of the recoil buffer is retained. |
| 1.302.044 T | Leakage of recoil buffer fluid and gas should be minimised. |
| 1.302.045 T | The design of the recoil brake shall be of such type, quality and dimension that the required safety margin against exceeding the maximum permitted recoil stress exists in all specified environments. |
| 1.302.046 T | Maximum recoil stresses shall be verified. |
| 1.302.047 T | Forced recoil equipment shall withstand recoil forces with a safety margin. |
| 1.302.048 T | If gas dampers are included in the recoil system, there shall be indication for recoil brake pressure.
<i>Comment:</i> The requirement refers to, among other things, inspection before shooting and preparation for maintenance. |

3.2.17 Composite and compound barrels

Materials in the form of non-metallic composites, plastics, compounds (mixtures of metal and composite), etc. are used to an increasing extent in weapon applications. These materials have different properties compared to metallic materials. Elongation and expansion in barrels and rocket/missile launch tubes can be significant factors. These properties are to be taken into account in the design and calculations for weapon systems.

1.302.049 T When designing non-metallic and compound barrels, consideration **shall** be given to expected changes over time of material properties.

1.302.050 T When designing fastening of external parts onto non-metallic barrels, consideration should be given to the influence of mountings that are permanently attached for example by winding, so that elongation properties are not negatively affected.

3.2.18 Recoilless weapons and rocket systems

Recoilless or minimal recoil systems and rocket systems are characterised by relatively little recoil and gas flow rearwards, among other things.

Ammunition handling is often performed manually. Different types of ammunition can be used in the same weapon system.

Recoilless weapons and rocket systems employ various solutions for ammunition handling:

- weapons for repeated use,
- weapons for limited repeated use,
- disposable weapons (for firing once only),
- fixed launch and aiming unit with replaceable, disposable barrel or launch tube.

3 Weapons

Such systems usually have sub-sonic muzzle velocities and relatively short ranges. The systems often have large danger areas rearwards compared to recoil weapons. Some systems, such as missiles, can be guided while in flight and this affects the danger area.

In recoilless systems the recoil is neutralised by the gas flow through the open rear end of the barrel which is equipped with a nozzle. The recoil force can be influenced by the design of the nozzle.

The mass of escaping gas can be augmented by solid or liquid substances, known as counter mass, which results in a lower blast pressure around the weapon.

Rocket systems are equipped with rocket motors in which combustion of the propellant takes place. The pressure in the launcher is determined by the static pressure of the escaping gases, which is usually much lower than in recoil systems.

- | | |
|--------------------|--|
| 1.302.051 T | Applicable requirements stated in <i>Section 3.2.3</i> above shall apply. |
| 1.302.052 T | Any residual recoil for recoilless launch tubes and rocket systems should be directed rearwards. |
| 1.302.053 T | Recoil forces shall be established. This can be carried out by means of calculation and/or testing. |
| 1.302.054 T | Back blast from a recoilless weapon, rocket or missile motor shall not cause injury to the operator/crew. |
| 1.302.055 T | Requirement <i>1.302.054 T</i> shall be verified by testing. |

3.3 OTHER WEAPON SYSTEMS

3.3.1 Minelayers for anti-tank mines

In some cases anti-tank mines can be laid mechanically, which means that hundreds of mines can be laid per hour. Usually the mines are fed from a towing truck so that only a small number of mines are in the minelayer at any one time. A plough-like device, for example, designed for the type of ground in question creates space beneath the surface in which the mines are laid.

Refer also to the requirements stated in *section 4.4, Fuzing systems*.

- | | |
|-------------|--|
| 1.303.001 T | If the minelayer arms the mine via a mechanical device it shall be equipped with an automatic monitoring system. |
| 1.303.002 T | A monitoring system as specified in requirement 1.303.001 T, shall emit both a light and sound signal when a mine becomes jammed in the minelayer. The alarm shall be reset manually. |
| 1.303.003 T | A minelayer that mechanically arms the mine shall enable access to a mine that becomes jammed without the necessity for the use of any tools. |
| 1.303.004 T | It shall be possible to decouple a minelayer that mechanically arms the mine from the towing vehicle to enable personnel and the towing vehicle to be moved out of the danger area of the mine within the duration of the safety delay including a safety margin.
<i>Comment:</i> If the above safety delay is 5+1 minutes it should be possible to decouple the minelayer from the towing vehicle and to move the personnel (with vehicle) outside the mine's danger area within two minutes. |

1.303.005 T The minelayer should be designed so as to minimise the risk of a mine becoming jammed during laying.

Comment: The shape of the mine should also be taken into consideration.

3.3.2 Launching equipment for underwater mines/depth charges

Underwater mines and depth charges are normally laid from a vessel under way (within a certain speed range). The mines can either be launched by rails over the stern of the vessel where they fall freely into the water, or by a mine laying device specially adapted for a specific type or many different types of vessels and mines.

Most underwater mines are too heavy to be lifted manually and therefore require lifting devices during handling.

The fuzing system is usually installed in the mine without the ignitor. It can then be finally assembled in an unarmed state immediately before laying/release.

Depth charges can be dropped from a launcher (from a vessel or helicopter) to form a ‘carpet’, i.e. with a certain distance between each depth charge to cover a specific area.

1.303.006 T The launching equipment **shall not** arm the mine before the mine leaves the mine laying device.

1.303.007 T The launching equipment **shall** be designed so that the mine cannot jam during launch.

Comment: The configuration of the mine is also to be taken into account, see requirement 1.401.027 T.

1.303.008 T For self-propelled mines and torpedo mines that are launched or dropped from surface vessels, submarines or helicopters, requirements in accordance with *Section 3.3.3*, launching devices for torpedoes and *Section 3.3.4*, beams and shovels **shall** apply.

3.3.3 Launch devices for torpedoes

Torpedoes are used as armament (weapon system) on submarines, surface vessels and helicopters. Torpedo launchers are commonly referred to as torpedo tubes or swim-out tubes aboard submarines, torpedo tubes aboard surface vessels and racks or launchers on helicopters.

In submarines, combat-ready torpedoes are stowed in the torpedo tubes and/or in stowage (standby mode) close to the torpedo tubes.

On board surface vessels, the torpedoes are normally stowed only in the torpedo tubes. Torpedoes are loaded into the torpedo tubes at the naval base/depot. A torpedo in tube is supplied to the vessel as a unit load.

In peacetime, torpedoes are used for exercise with the warhead replaced by a special exercise head. After a practice run the torpedo is recovered and reused. It can also be reused as a combat torpedo after being refitted with a warhead etc.

Torpedoes are heavy (250 – 1 800 kg), and require lifting devices to facilitate handling.

The SAI (Safety-Arming-Ignition device) is normally stored separately from the torpedo, and is provided with a transport safety device or other safety locking of the ignition system. It is installed in the torpedo in conjunction with the final issuing of the torpedo from the base.

The SAI (Safety-Arming-Ignition device) arms the warhead when the safety distance has been reached and all arming conditions are met.

3 Weapons

Three types of systems are currently used to launch torpedoes from submarines: Push-out/Piston launch, Flush-out and Swim-out. Internationally, all three methods can be found, but in Sweden only Swim-out is used:

- Push-out/Piston launch; compressed air that actuates a piston located aft of the torpedo that forces both the torpedo and the water out of the torpedo tube.
- Flush-out; discharge of the torpedo from the torpedo tube with water that is powered by a heavy-duty pump.
- Swim-out; the torpedo tube is filled with water and doors in the outer and pressure hulls are opened, whereby the torpedo starts and swims out. The torpedo tube has a larger diameter than the torpedo and is equipped with a rail system that leads the torpedo out through the tube.

Torpedo launch from a surface vessel is performed by an overpressure in the torpedo tube aft of the torpedo. This overpressure is generated either by combustion of a propelling charge or by compressed air. From simpler platforms, a chute (gravity launcher) is used where the torpedo as a result of its own weight slides down into the water. The SAI arms the warhead when the torpedo has reached the safe separation distance.

- 1.303.009 T** Torpedo tubes **shall** be equipped with sensors that indicate that the torpedo has left the tube after it has been launched.
- 1.303.010 T** Torpedo tubes **shall** be so designed that the torpedo cannot jam on its way out of the tube or in the torpedo room of submarines.
Comment: The design of the torpedo is also to be taken into account.
- 1.303.011 T** It **shall not** be possible for the testing of a launcher to cause inadvertent launch.
Comment: The test system is normally separated from the launch system.
- 1.303.012 T** Power up (such as at system check, simulation or before launch) of a torpedo **shall not** lead to inadvertent launch.

- 1.303.013 T For torpedoes incorporating hydrogen peroxide, the torpedo tubes and standby storage **shall** be equipped with a draining system connected to the hydrogen peroxide system of the torpedo.
- 1.303.014 T Material and components used in the drainage system **shall** be chosen so that they are compatible with highly concentrated hydrogen peroxide.
Comment: See instructions and requirements in HANDBOK VÄTEPEROXID, M7780-252981.
- 1.303.015 T The drainage system **shall** be designed for the maximum number of torpedoes used on board.
Comment: When designing/dimensioning drainage systems on board submarines, the probability of abnormal decay of VP85 must be taken into account. See also instructions and requirements in HANDBOK VÄTEPEROXID, M7780-2529811.
- 1.303.016 T In an emergency situation, it **shall** be possible to jettison the torpedoes from a helicopter, emergency launch from a surface vessel and emergency launch with the use of a separate back-up firing panel from a submarine.
- 1.303.017 T For torpedoes, requirements 1.302.001 T and 1.302.018 T **shall** apply.

3.3.4 Launchers and pylons

Launchers and pylons are attachment elements for weapons and munitions such as bombs, dispensers (for multiple weapons), rockets, missiles and torpedoes. The functions that are built into the pylon or munition vary according to the application.

1.303.018 T A pylon/launcher **shall** enable a transport safety device in the form of an indicator or equivalent to be clearly visible while the munition is in transport safe mode.

1.303.019 T A pylon/ launcher as specified in requirement *1.303.018 T* should enable the transport safety device to be carried together with the munition.
Comment: This enables replacement of the transport safety device if the aircraft lands at a different site from the ammunition preparation site.

1.303.020 T Pylons/launchers **shall** enable separation of the weapon system or munition in such a way that there is no risk of collision with weapon platforms.
Comment: This includes incorrect manoeuvring of the ammunition.

3.3.5 Weapon platforms

There are numerous types of platforms (aircraft, naval vessels, vehicles, etc.) for a weapon system, which means that requirements vary according to the type of platform in question.

Generally, each type of platform shall comply with applicable legislation and regulations, although in some cases supplementary requirements may be necessary.

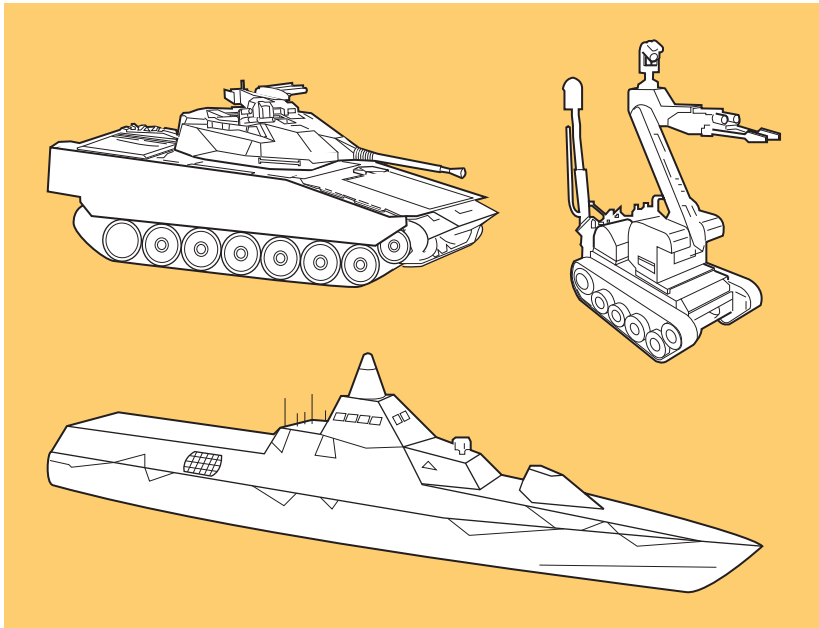

Figure 3:6 Examples of Weapon Platforms

1.303.021 T The platform **shall** satisfy applicable traffic regulations for civil and military use.

Comment: Dispensation may be given.

1.303.022 T Sound pressure from the launch/firing **shall** be acceptable for the crew. Verification is required, see *Section 3.1.7*.

3.3.6 Openings/hatches and doors

Hatches and doors must meet certain specific requirements. They are to be sufficiently stable to withstand shockwaves close to a detonation and subsequently be possible to open. Specific safety requirements concerning manoeuvrability, locking, opening etc. must be met.

1.303.023 T The locking/bolt mechanism **shall** be designed to withstand the stresses arising during operational use.

1.303.024 T The locking/bolt mechanism should be accessible and manoeuvrable from both inside and outside.

1.303.025 T Locks on hatches and doors should be manoeuvrable by crew wearing regulated personal protective equipment at all extreme temperatures.

3.3.7 Sights and aiming systems

It is obvious that a serious accident may occur if the weapon is fired in the wrong direction. Such an event can be caused by a fault in the sight, or a fault in the laying and firing function caused by human error or a combination of these.

The possibility of an error by the user makes it essential to stipulate requirements to ensure that the system is designed according to sound ergonomic principles and that it is easy to operate. Dials and displays must be unambiguous and legible in all conceivable situations. Controls must be conveniently located for the crew and facilitate the performance of their tasks.

Generally it can be stated that serious accidents can be minimised through good design, including ergonomics.

1.303.026 T There **shall** be devices to prevent the armament being aimed or fired in prohibited directions such as towards fixed obstacles.

Comment: During maintenance, it is permissible to aim in prohibited directions.

3.3.8 Guidance and control systems

For guided weapons (missiles, torpedoes, etc.) the path is determined after separation from the weapon platform based on the following criteria: the condition of the weapon platform at separation, the characteristics of the propelling charge/motor, the predetermined firing data, and the design and characteristics of the guidance system. The level of complexity of a guidance system can vary. It generally incorporates guidance controls, servo motors, and some type of processor to generate guidance signals which can emanate from the weapon platform as well as from the missile/torpedo itself. Signals from the weapon platform can be transmitted via a link utilizing electromagnetic waves of suitable frequency such as radar, thermal or light, or electrically/optically by wire during part of or the whole flight path.

Guided weapons/munition often employ search and fire control devices that acquire target data via active sensors (based on e.g. radar, laser) with potentially harmful properties. Furthermore, there is often a turntable or mobile platform and, for example, even a ground installation that also involves hazards. Surveillance and fire control systems are dealt with in other sections in this manual, see *section 3.1.4, Electrical and magnetic fields*, *section 3.1.15, Lasers* and *section 3.3.7, Sights and aiming systems*.

Guidance systems contain sensors, guidance electronics/software, guidance controls, and possibly additional functions such as communication links, guidance beams or indication equipment (e.g. radar beacon or tracer). All this equipment requires power – electric, pneumatic, hydraulic, for example – in addition to the power normally required for an unguided system.

Self-destruction and control of the warhead function may be incorporated. Elementary examples of this include arming after a specific flight time, or proximity fuze trigger, based on approach velocity.

3 Weapons

Subsystems in weapons/ammunition affect guidance in one way or another. For example, if the propulsion motor stops/fails the guidance performance is changed dramatically, and the same applies to the energy supply. An actual guidance system incorporates an automatic guidance function with associated rudder system, sensor unit and target seeker. These units, together with computers and system geometry, form a closed loop guidance system that must be precisely designed for optimal functioning and performance.

Prior to launch and separation of the weapon from the weapon platform, all subsystems are prepared with initial values while essential functional checks are performed simultaneously so that the separation conditions are satisfied. The separation sequence may involve constraints on guidance signals and rudder deflection to prevent any risk of the munition colliding with the weapon platform, or any risk of the munition acquiring excessive angular acceleration with regard to the equipment and subsystems incorporated. Different guidance methods can be applied during the various stages of the flight path such as control of attitude, proportional navigation with lead bias, inertial navigation and Semi-Active Command by Line Of Sight (SACLOS), depending on the design and performance requirements for the weapon.

The purpose of the requirements is to ensure:

- safe handling during transport and deployment,
- safety in and around the fire unit during loading, unloading, loaded fire unit and launch,
- safety outside the designated danger areas,
- safety during training, loading exercises, and operation of the launch unit.

1.303.027 T Sources of radiation aimed at the launch unit from the guided weapon/munition should be so designed that they do not require any danger zones at the launch unit.

1.303.028 T Sources of radiation for guidance that can have a dangerous effect **shall** be indicated to the operator when transmission is in progress.

1.303.029 T	During exercises the indication specified in requirement 1.303.028 T should also be visible to anyone anywhere in the vicinity.
1.303.030 T	It shall not be possible for guidance signals to the weapon/munition to initiate motor or warhead igniters.
1.303.031 T	The guided weapon/munition should incorporate a function which, in the event of a target miss, or if a malfunction is detected which definitively precludes effect in the target, renders the weapon safe. <i>Comment:</i> This can be achieved, for example, by self-neutralisation, self-destruction, or sterilisation.
1.303.032 T	There should be a system for function monitoring and fault detection for the guidance system. This may result in self-neutralisation or sterilisation of the weapon, etc.
1.303.033 T	The guidance system shall be designed and documented in a way that enables a safety analysis to be performed.
1.303.034 T ^a	The safety analysis shall be performed or audited by a party that is independent of the designer. <i>Comment:</i> Another department or special safety function within the same company may be considered as an independent party.
1.303.035 T	All materials incorporated shall be selected and combined in such a way that effects detrimental to safety do not arise during the life of the guidance system, for example as a result of corrosion, ageing, chemical change or short-circuits.

3 Weapons

1.303.036 T Data transfer between the weapon and fire control, both before and after launch, should conform to standardised communication protocols.

1.303.037 T Data transfer between the weapon and fire control, both before and after launch, **shall** be subject to function monitoring.

Comment: Function monitoring can, for example, be by means of parity checking or a ‘watch-dog’ function.

- a. Please note that this requirement was given the wrong number (1.303.033 instead of 1.303.034) in the printed, Swedish version, July, 2020. However, this has been corrected in the digital edition and requirement checklist.

3.4 OTHER

This section deals with pressure vessels, lifting devices and fire-fighting equipment. These types of equipment and devices do not normally belong to the actual weapon systems but have characteristics or features that affect the safety of some weapon and ammunition systems.

3.4.1 Pressure vessels

There are a number of types of pressure vessels for many different applications. Structural strength calculations and hydrostatic testing shall always be carried out to provide the basis for type approval.

1.304.001 T Pressure vessels **shall** be type approved in accordance with the Swedish Work Environment Authority’s regulations.

3.4.2 Lifting devices

Lifting devices are used to lift parts of, or complete, systems during production or in the field. An assurance of compliance with the regulations governing lifting devices shall be submitted in writing by the manufacturer. This means that applicable standards have been adhered to, structural strength calculations have been performed, hazard analyses have been carried out, an instruction book has been compiled, test certificates have been issued, material certificates are available, and that the lifting device has been CE marked.

1.304.002 T Lifting devices intended for use in military equipment **shall** undergo a process similar to that of CE marking.

Comment: The process is the same as for CE marking of products according to EU directives, with the only difference that the products that follow the process are not marked with the letters “CE” on the product's nameplate. See also *H SystSäk*, the Machinery Directive, and AFS.

1.304.003 T The danger area for a lifting device **shall** be established and taken into consideration when formulating Safety Restrictions.

Comment: The danger area is greater than the area immediately beneath a hanging load, for example.

3.4.3 Fire-fighting equipment

Fire, especially in ammunition stored in confined spaces, can become catastrophic in a very short time. Even fire in other equipment can quickly lead to major health hazards to the crew, especially in a combat vehicle. It is therefore vital that a fire can be extinguished as quickly as possible before the crew is injured by the fire itself, or by toxic substances released during certain types of fire.

Fire-fighting equipment comes in the form of fixed equipment and hand-carried extinguishers.

Fixed fire-fighting equipment can usually be activated automatically as well as manually.

Fixed sensors that react to smoke and/or temperature, for example, are in general use.

The primary purpose of the requirements is to ensure the safety of the crew, and secondarily to save the weaponry.

For specific requirements for fire-fighting equipment in vehicles, vessels and aircraft please refer to the applicable handbooks and regulatory framework (H FordonSäk, RMS and others).

4 AMMUNITION

The term ammunition denotes materiel that is designed to achieve damage in the widest sense with explosive force or kinetic energy, produce smoke, illuminate the battlefield, or achieve electromagnetic jamming. Ammunition also includes training systems for the above. Packaging is also included in the concept ‘ammunition’.

This chapter specifies the requirements that are unique to ammunition including its constituent parts: warheads, fuzing systems, propulsion parts, and packaging. Where a weapon part such as a barrel, dispenser, pylon, etc. is a constituent part of the system *Chapter 3* also applies.

With regard to guidance systems for ammunition that affect the ammunition after it has left the launcher, refer to *Section 3.3.8*.

For all types of ammunition, the requirements related to operations and materiel as described in *Chapter 2* shall always be taken into account. Thereafter, the common ammunition requirements under *Section 4.1* and system-related requirements for munitions (different parts) are to be taken into consideration; along with warheads in *Section 4.2*, launching and propulsion systems in *Section 4.3*, fuzing systems in *Section 4.4* and packaging for ammunition in *Section 4.5*.

It is crucial that ammunition is developed in accordance with all the applications in question, and that the characteristics that are decisive for safety in a specific application are documented. As more specialised functions are incorporated in munition – such as proximity fuzes, terminal guidance, and the various advanced guidance systems used in guided weapons – increasingly comprehensive safety programs and documentation will be needed.

4.1 COMMON AMMUNITION REQUIREMENTS

This section specifies the requirements that are applicable for a complete munition. These requirements together with the other applicable weapon and ammunition safety requirements shall be incorporated in the requirement specifications.

4.1.1 Insensitive Munitions (IM)

For many years, there have been a number of major accidents internationally involving ammunition, which caused extensive injury to own personnel and damage to equipment. Modern technology in weapons development has made it possible to develop ammunition that exhibits low sensitivity to extreme but likely threats in the form of heat, shock or the impact of weapons. This increases the ammunition's durability in battle from a logistics and tactical point of view, it reduces the risk of injury to own personnel and allows for cost-efficient storage, transport and handling.

To develop and introduce low sensitivity properties is part of the general systems safety program that is being carried out for all of the Armed Forces' products.

The reduced sensitivity is often achieved as a result of the explosive substance being phlegmatized with a plastic bonding agent. These explosives are often referred to as PBX (Plastic Bonded Explosives). IM properties are not only met through measures on the explosive substance, but also mechanical or electronic design constructions are used on the ammunition. IM can also be achieved through the characteristics of the weapons installation, packaging, etc.

1.401.001 A During procurement, overhaul, or modernisation of ammunition for the Swedish Armed Forces, ammunition with sufficient IM properties shall be considered.

Comment: The desired IM properties are to be assessed in each case with regard to the threat, the desired effect (performance), the risk of injury and cost. Requirements for IM properties are to be established in the Armed Forces' Operational Requirements (SMS).

1.401.002 A The potential threats that an ammunition item could be subjected to should be determined with the help of a THA (Threat Hazard Analysis) which covers all the phases in the service life of the munition.

Comment: For each individual threat, it is necessary to identify what tests has to be conducted and the type of reactions that may be permitted in order to verify the desired level of insensitivity. The work is carried out in accordance with STANAG 4439 and AOP-39. If threats are detected which are not defined in STANAG 4439, these should also be addressed.

4.1.2 Additive manufacturing of explosives

Additive manufacturing, also called free-form manufacturing or 3D printing, has developed from the manufacture of parts in plastic and metal to also be applied in the manufacture of parts in explosive materials. In the civilian industry, additive manufacturing is used for many needs and a number of methods have been developed. There is also an interest in the military field and methods are being developed for manufacturing explosive components with additive methods.

From an ammunition safety perspective, it should be emphasized that today's requirements for warheads and propellants come from experience based on manufacturing with traditional methods (for example casting and pressing of components).

4 Ammunition

The requirements have been designed to prevent manufacturing defects associated with these methods. There are also general requirements that capture the products that are manufactured with additive methods, but new methods will be required to show that, for example, the quality system captures safety-critical errors.

4.1.3 Batteries

Batteries are used as an electrical power source in many weapon systems and various types of ammunition.

With the development of batteries and the fact that electronics have been used more for control and management in various technology solutions, the capacity of the batteries has increased as well as the need for longer operating time and higher current/voltage levels.

Battery chemistry and function can vary greatly depending on current, voltage, operating time, and more.

It should be noted that both the chemically stored energy, which in the event of a short circuit or leakage can create fire or other secondary faults, as well as high current and voltage levels can be sources of risk for both personnel and equipment. These sources of risk must be considered when implementing the chosen battery solution for a weapon system or ammunition.

- 1.401.003 T When designing weapon systems or ammunition with batteries, hazards with regard to batteries **shall** be analysed and reported.
Comment: Risk of injury due to high current and voltage levels, short circuit, leakage and more are to be taken into account.
- 1.401.004 T The structure and operating principle of batteries **shall** be reported, among other things, with regard to the constituent chemical substances and quantities thereof.
Comment: Chemical substances in batteries can affect transport classification and the possibility of co-storage, as well as measures required by chemical legislation.
- 1.401.005 T Every project that intends to use batteries in a design **shall** get assurance from an accredited authority about the possibility of co-storage with explosive goods.
Comment: In addition to risks with stored chemical energy, there may also be risks with leakage of battery electrolyte over time and compatibility problems with other substances, for example with explosive goods and risks of self-ignition.
- 1.401.006 T High temperatures generated by batteries in normal operation **shall** be considered and verified in the application where they are intended to operate.
Comment: Placing batteries near explosive products can lead to hazard ignition of the explosive, poorly thermally protected cabling can lead to short circuits and more.

4.1.4 Chemical legislation and FMV's chemical management

Ammunition is covered by two EU regulations concerning chemicals: Reach¹ and CLP². EU regulations apply directly in all Member States without first being transposed into national law.

The REACH Regulation comprises, among other things, requirements on the registration of substances, prohibitions or other restrictions on substances, requirements for authorisation for substances of very high concern and requirements on informing customers. As most ammunition contain chemical substances, these are thus covered by REACH. The requirements and obligations of industry under REACH can vary widely in scope depending on how the ammunition is classified according to the definitions in the Regulation.

The ammunition can either be classified by the industry as:

- a. a substance or mixture of chemical substances, or
- b. a combination of an article and a substance/mixture, or
- c. an article.

It is central to obtain information stated above when procuring ammunition as well as information that ensures knowledge that the supplier fulfills commitments and obligations according to REACH. This is important in order to be able to get an overview of any impact on the security of supply of the ammunition, as the effect of REACH will be, among other things that substances of very high concern will require an authorisation for use or will be completely banned in the long term.

-
1. Regulation (EC) No 1907/2006 on the registration, evaluation, authorization and restriction of chemicals (REACH).
 2. Regulation (EC) No 1272/2008 on the classification, labeling and packaging of substances and mixtures (CLP).

In support of industry classification, there is guidance from the European Chemicals Agency (ECHA)¹ and the Member States' common position on the classification of ammunition under REACH, through the European Defence Agency (EDA)².

The Candidate list is a part of REACH and comprises about 200 substances of very high concern (up to year 2020, the list is updated with new substances every six months). If an article contains more than 0.1% by weight of a substance included in the Candidate list, the supplier of the article must provide information so that the recipient can use the product safely. The information must at least include the name of the substance. This applies even if the recipient of the product cannot come into contact with the substance during use.

Authorisation for use or placing on the EU market is required for certain substances of very high concern. This applies regardless of the amount of substances handled. Substances subject to authorisation are listed in Annex XIV to REACH.

The CLP Regulation contains requirements for classification, labeling and packaging of chemical products. Ammunition may be covered due to the definition of “explosives” in the Regulation.

Ammunition that are classified as chemical products can be covered by the Swedish Chemical Products and Biotechnical Organisms Ordinance (2008:245), where, for example, obligation to report the product to the Products Register is stated. Chemical products subject to registration are those whose customs tariffs are stated in the customs tariff number list (Annex to the Ordinance). If the annual volume per product is at least 100 kg, the product must be registered by the legal person who manufactures the product or imports it to Sweden.

-
1. “Guidance on requirements for substances in articles”, <https://echa.europa.eu/en/guidance-documents/guidance-on-reach>.
 2. “EDA Member States Common Position on Ammunition Classification under REACH”, <https://www.eda.europa.eu/what-we-do/activities/activities-search/reach>.

The Defence Sector's Criteria Document – chemical substances, chemical products and articles – shall be applied throughout all FMV's activities. in accordance with the decision of the authority's management. It is a common document for the authorities in the defence sector that restricts which chemical substances may be present in articles and chemical products. Ammunition are also covered by these restrictions. The basis of the Criteria Document is the EU regulations REACH and CLP. In order to promote the development of chemical products and articles having less effect on human health and on the environment, the Criteria Document in many cases establishes stricter requirements than current chemicals legislation.

1.401.007 A With reference to the REACH Regulation (EC No 1907/2006), the supplier **shall** classify the ammunition as:

- a. a substance or mixture, or
- b. a combination of an article and a substance / mixture, or
- c. an article.

1.401.008 A Based on the classification of the ammunition according to requirement *1.401.007 A*, the supplier **shall** inform about how obligations imposed by the Reach regulation are handled, and submit such information or documentation that follows from imposed obligations.

Comment: Documentation can, for example, be safety data sheets or substances included in the candidate list.

1.401.009 T With reference to the CLP Regulation (EC No 1272/2008), the ammunition shall be labeled in accordance with CLP, if the ammunition is covered by the aforementioned Regulation.

1.401.010 A Information on chemical substances included in the ammunition **shall** be documented as follows:

1. Chemical name of the substance,
2. CAS number,
3. Concentration (percentage by weight).

Comment: The information is to be documented, for example in current register or in the appendix Environmental Plan to System Life Cycle Plan (SLCP).

1.401.011 A Information whether the ammunition contains a Candidate List substance, present in a concentration above 0.1% by weight, **shall** be documented.

As a minimum, the name of the substance and CAS number for the substance in question **shall** be documented.

Comment: The information is to be documented, for example in the Basic and Management Data or in the appendix Environmental Plan to System Life Cycle Plan (SLCP).

1.401.012 A Information whether the ammunition contains a substance included in Annex XIV to Reach **shall** be documented.

If the substance included in Annex XIV requires an authorization for use, the supplier **shall** inform how the obligations imposed by the REACH Regulation are handled, when relevant.

Comment: The information is to be documented, for example in current register or in the appendix Environmental Plan to System Life Cycle Plan (SLCP).

1.401.013 A Emissions to the surrounding environment in connection with the effects of the ammunition when used **shall** be mapped to a sufficient extent to support the needs of the Swedish Armed Forces.

Comment: The information provides a basis for assessing the environmental impact on firing ranges, etc., which may have a bearing on the Swedish Armed Forces'/FMV's environmental permit.

4.1.5 Other ammunition common requirements

1.401.014 T	<p>Data for assessment of the danger area shall be created for all combinations of launchers and ammunition.</p> <p><i>Comment:</i> Data is created by analysis and tests, for example with respect to the danger area for lasers, shrapnel, thermal radiation, and sound pressure etc.</p>
1.401.015 T	<p>The projectile and propelling charge shall be designed so that the projectile remains in the rammed position with the gun at maximum elevation without any special devices being needed on the gun.</p> <p><i>Comment:</i> The above applies for ammunition where ramming is desirable. This is particularly important when the projectile and propelling charge are separated. See also <i>Section 3.2.15</i>.</p>
1.401.016 T	<p>The function stated in requirement 1.401.015 T shall be tested using a worn barrel.</p> <p><i>Comment:</i> Refer to the definition of a worn barrel.</p>
1.401.017 T	<p>Ammunition should be designed so that clearing/unloading can be performed in a safe manner by the crew operating the weapon.</p> <p><i>Comment:</i> This also applies to clearing/unloading after an ammunition misfire.</p>
1.401.018 T	<p>Verification of requirement 1.401.017 T shall include testing of what forces can be permitted for the unloading tool in question.</p> <p><i>Comment:</i> Testing also includes the force required to achieve clearing/unloading.</p>
1.401.019 T	<p>To establish the risk of cook-off for the ammunition, the temperature/heat flux etc. for a barrel at its maximum operating temperature and for the shell shall be determined. Refer also to requirements 1.302.029 T and 1.302.030 T.</p>

1.401.020 T Driving bands, casings or equivalent **shall** be designed so that they do not inadvertently disintegrate outside the barrel when firing.

1.401.021 T Sabots and separating driving bands shall be designed to ensure safe separation.
Comment: The risk of sabot fragments and any change in projectile trajectory has to be considered.

1.401.022 T Driving bands, sabots, obturators, casings etc. should be designed so that no fragments are formed that can impact the muzzle brake (if fitted) and ricochet rearwards.

1.401.023 T Projectile **shall** be designed to achieve external ballistic stability in all permitted types of firing so that specified danger areas are still valid.
Comment: Worn barrels, driving bands, fins etc. can affect external ballistics.

1.401.024 T Explosives incorporated in the ammunition **shall** be qualified in accordance with FSD 0214 or with applicable international standard, such as STANAG 4170.
Comment: Assessments concerning the scope of qualification can be made by the Advisory Group for Explosives (Rg Expl), see *Section 2.6.3*.

1.401.025 T The ammunition should be able to withstand abnormal environments such as accidents or the effects of enemy fire so that together with the system's safety measures, it contributes by making the vulnerability of the system as low as possible.
Comment: The above is to be based on the robustness of the ammunition and the protection level of the system. Compare STANAG 4439. See also *Section 4.1.1, Insensitive Munitions (IM)*.

- 1.401.026 T Torpedoes **shall** be designed so that they do not jam in launch tubes. Compare requirement 1.303.010 T.
- 1.401.027 T Landmines, underwater mines and depth charges **shall** be designed so that they don't interfere with or get stucked in mine-laying equipment. Compare requirement 1.303.007 T.
- 1.401.028 T The safe separation distance/time **shall** be established for the severest case of operational use. Refer also to requirements 1.301.014 T, 1.402.021 T, 1.403.007 T and 1.404.014 T.
- 1.401.029 T The design and the materials used in munition **shall** be chosen to enable the casing to withstand all stresses arising, including pressure in the barrel, without exceeding acceptable deformation.
Comment: In the design of the ammunition the pressure definitions and procedures stated in STANAG 4110 are to be applied.
- 1.401.030 T Incorporated materials **shall** be compatible.
Comment: See also requirement 1.202.002 T.

4.2 WARHEADS

This section is a summary of common requirements for warheads. For each type of warhead there are additional object specific requirements that apply which are stated in other sections.

The term warhead refers to that component of the ammunition which, at a predetermined time or place (e.g. impact in target, actuation in immediate proximity of target, etc.) is intended to provide effect by, for example, pressure, fragmentation, or incendiary, or any combination of these, or any other effect of tactical importance to the user.

In certain circumstances such an effect is achieved after entry or penetration of for example, armour or, other protection element. Anti-tank projectiles which as a result of high kinetic energy penetrate armour are examples of warheads that have no explosive charge. Furthermore, there are pyrotechnic warheads (illuminating, incendiary, smoke). Most combat warheads have practice equivalents which – on impact – provide some kind of visual signal, such as a flash or smoke, to indicate point of impact and which have a lower explosive effect. There is also practice ammunition whose warheads contain little or no explosive (c.f. inert ammunition that has no explosive content at all).

Thermobaric weapons work on the principle that a mixture of metal powder and a combustible liquid is blasted out and burned in the ambient air. On combustion, the air is heated up resulting in an increase in pressure. The pressure is lower than in a conventional explosive, but with a longer duration. The effect is achieved within a well-defined area.

For multiple warheads, each submunition is considered as an individual warhead. In the case of guided and trajectory corrected weapons the warheads are covered as described in this chapter, while the guidance and trajectory correction motors are covered in *Section 4.3*. with consideration given to the actual launch environment. When initiating such motors, the same requirements are specified as for fuze systems for propulsion devices, see *Section 4.4.8.9*, if it is not proven that hazard initiation does not incur injury to personnel nor damage to property or the environment.

4.2.1 Environments for warheads

The following are examples of the consequences of mechanical stress caused by the environment:

- leakage can occur in joints,
- cracks can occur in warhead casings,
- fatigue,
- explosive dust or similar can be created and be found in more sensitive places, e.g. threaded joints and gaps where there may be a risk of initiation due to vibration or shock (e.g. during firing).

Examples of consequences resulting from the physical and chemical effects of the environment:

- high explosives can be heated to a temperature at which they deform plastically or melt. This can lead to cavities, or the high explosive migrating into threaded joints, between separating surfaces, or into cracks and crevices where it can be compressed and thus involve a risk of initiation,
- air may be pumped in and out through leaks in the warhead casing which can lead to the accumulation of condensation. The high explosive may be affected and gaseous products may form, for example in the case of high explosives with an aluminium content,
- brittle fractures can occur in the casing, especially at extremely low temperatures,
- a significant difference between the coefficients of expansion of the charge and the casing can result in the formation of cracks or cavities at low temperature, or high internal over-pressure can result at high temperature,
- reactions between incompatible materials can change the properties of explosives.

4.2.2 Joint requirements for warheads

1.402.001 T	Warheads of CBRN type (chemical, biological, radioactive, or nuclear weapons) shall not be developed.
1.402.002 T	Warheads, in which fuel is sprayed into the air and detonates owing to the oxygen in the air and where the main purpose is anti-personnel, should not be developed. <i>Comment:</i> Must meet requirements 1.203.001 A and 1.203.006 A regarding the prohibition of indiscriminate effect and firearms. May also produce effects equivalent to chemical weapons in cases where the gas is toxic and does not ignite, which is also prohibited, see requirement 1.402.001 T.
1.402.003 T	Warhead casings whose main effect is fragmentation shall be made of material that can be easily detected by X-ray.
1.402.004 T	Multiple weapons and guided weapons shall be considered as several warheads and propulsion devices. Separation charges and guidance or trajectory correction motors shall be treated as propulsion devices.
1.402.005 T	The design of and the materials used in the warhead shall be chosen to enable the casing to withstand all stresses arising, including pressure in the barrel, without exceeding acceptable deformation. <i>Comment:</i> Example of detailed requirements stipulated: Safety margin for deformation, freedom from cracks, overlaps, pores or incorrect heat treatment that can lead to hazardous events. With regard to pressure in the barrel, refer to <i>Chapter 3</i> .

- 1.402.006 T** When tempered steel is used in the casing the material and heat treatment chosen **shall** be such that hydrogen embrittlement or other dangerous corrosion does not occur.
- 1.402.007 T** The internal surface of the casing **shall** be smooth and clean.
Comment: The warhead casing must be protected from moisture and foreign particles before casting/filling of the explosive.
- 1.402.008 T** The design and composition of HE charge (High Explosive charge) and pyrotechnic charge **shall** be such that they can withstand all stresses arising without any risk of a hazardous event occurring.
Comment: Testing is carried out in accordance with FSD 0060 or other relevant international standard. See also *Section 4.1.1, Insensitive Munitions (IM)*.
- 1.402.009 T** The warhead **shall** be designed to avoid the presence of high explosive or pyrotechnic composition in threads or joints in such a quantity as to create a risk of inadvertent initiation when screwing components on or off or at launch or release.
- 1.402.010 T** Requirements *1.402.008 T* and *1.402.009 T* **shall** be verified by testing.
Comment: The parts in the warhead can be examined prior to testing by using X-ray, radiography, ultrasonic testing or other methods.
- 1.402.011 T** The warhead **shall** not be susceptible to cook-off in the event of a misfire or interruption in firing when the barrel is at its maximum operating temperature for the operational profile in question.
Comment: Refer also to requirements *1.302.029 T* and *1.403.019 T*.

- 1.402.012 T The melting point of the high explosive should be higher than the temperature reached by the ammunition in a barrel heated to its maximum operating temperature for the operational profile in question.
- 1.402.013 T The warhead in its application should not detonate in the event of fire.
Comment: This requirement is part of the IM requirements defined in STANAG 4439. See also requirements 1.401.001 A and 1.401.002 A.
- 1.402.014 T Requirement 1.402.013 T should be verified by testing.
- 1.402.015 T The warhead in its application should not detonate from bullet attack from small calibre ammunition.
Comment: This requirement is part of the IM requirements defined in STANAG 4376. See also requirements 1.401.001 A and 1.401.002 A.
- 1.402.016 T Requirement 1.402.015 T should be verified by testing.
- 1.402.017 T The design of the warhead **shall** facilitate upgrading, in-service surveillance and disposal.
- 1.402.018 T The possible identification and destruction of UXO (unexploded ammunition) **shall** be taken into account during the design of the warhead.
- 1.402.019 T The blast pressure from a detonating warhead **shall** be determined to be used to calculate the danger area.
Comment: This applies, among other things, to hand grenades, thunder flashes and spotting charges. See also *Section 3.1.7*. For applications in underwater environments, see *FM Reglemente Sjösäkerhet vapen; M7739-353134^a*.

1.402.020 A Environmental aspects arising from manufacture, use and clearance of UXO (unexploded ammunition), recovery of target materiel, and disposal **shall** be taken into account.

Comment: The information is documented in the appendix Environmental plan to System Life Cycle Plan (SLCP).

1.402.021 T A safe separation distance **shall** be established for all warheads, see also requirement *1.401.028 T*.

a. Armed Forces' Regulations for Maritime Safety Weapons, not translated to English.

4.2.3 Warheads containing High Explosive (HE)

This section contains object specific instructions for warheads containing high explosive. A breakdown of the instructions have been made for high explosive warheads for tube-launched ammunition, rockets and missiles, bombs, land mines, underwater ammunition and other munitions. In addition, the common requirements specified in *Chapter 2* apply.

4.2.3.1 High explosive warheads for tube-launched ammunition

HE warheads for tube-launched ammunition for cannons, howitzers, mortars, and recoilless tube weapons are dealt with herein.

Besides a fuze, HE shells consist primarily of a shell body filled with a high explosive which may be pressed or cast. The design is dimensioned to withstand high pressure and high acceleration and, where relevant, spin.

Exercise shells with a reduced charge are similar to HE shells but have ballast and a greatly reduced charge that on burst produces a flash and smoke to facilitate observation of the impact point. The quantity of high explosive is reduced to such an extent that neither injury to the gun crew nor damage to the gun shall occur in the event of premature detonation in the barrel. If this condition cannot be met in the design, the practice shells shall be considered in the same way as HE shells from a safety aspect.

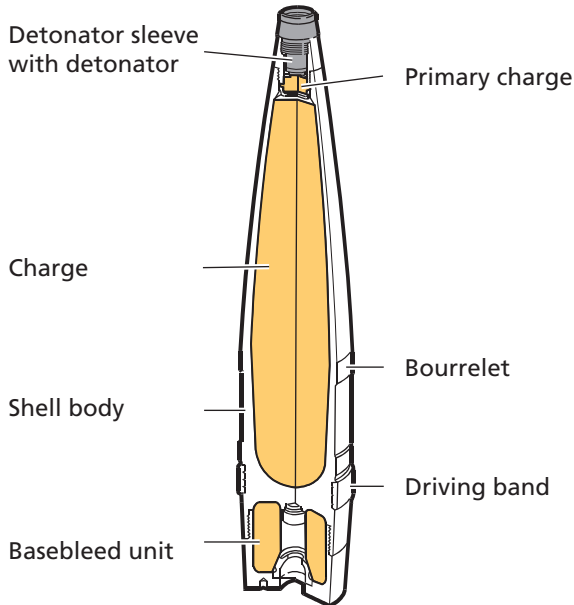

Figure 4:1 Example of high-explosive shell

Typical characteristics of tube-launched ammunition are that the projectile is subjected to high pressure, high temperature and acceleration, and often spins in the barrel, as well as aerodynamic heating while in flight. This means that the safety of the design must be examined carefully with regard to stress etc.

Material defects can have a critical effect if leakage occurs allowing hot propellant gases to enter and ignite the charge. Shell bodies may exhibit leaks in the base (so-called pipes), which is why the base is usually fitted with a metal base plate or other device that provides a seal. A coarse inner surface in the shell body may increase the risk of a hazardous event owing to increased friction.

The sensitivity of the warhead in question is significantly dependent on the quality of the high explosive, its freedom from foreign particles and its application. Pipes, cavities, and cracks (especially close to the base) may cause settling of the high explosive during firing, which in turn can lead to premature ignition by adiabatic compression (with subsequent detonation in the barrel).

The explosive charge in a shell may in the event of jamming be heated up in the barrel to a temperature above its melting point temperature so that the characteristics of the explosive charge are changed and, at worst, results in the inadvertent detonation of the explosive charge (known as cook-off).

In the case of rocket assisted projectiles it is important to consider the effects of thermal conductivity and erosion on the wall separating the rocket motor from the high explosive charge.

The driving band – usually made of copper, a copper alloy, plastic, or sintered iron – can be a safety-critical item. Defects in the material or in the manufacture of the driving band may lead to disintegration in the barrel, which in turn may cause a hazardous event.

1.402.022 T If it is likely that the material from which the shell body is fabricated may contain pipes, a base plate or equivalent **shall** be employed and be attached in a satisfactory manner.

1.402.023 T When filling a shell body with high explosive it **shall** be ensured that unacceptable pipes, cavities, gaps or cracks do not occur and that required adhesion is achieved.

Comment: The level of defects; quantity, size, etc., must be dealt with in each item according to the explosive chosen and environment specific requirements.

1.402.024 T Requirement *1.402.023 T* **shall** be verified by X-ray inspection, sawing the shell bodies, or by the use of bisectable shell bodies.

1.402.025 T Pressed shell bodies **shall** be free from explosive dust.

- 1.402.026 T Pressed explosive bodies **shall** keep the prescribed freedom from unacceptable defects such as cracks.
When pressing explosive bodies, it **shall** be ensured that unacceptable defects (for example cracks) do not occur.
Comment: Levels regarding defects, number, size and so on must be taken care of in each individual object with regard to the selected explosive and environment specific requirements.
- 1.402.027 T Any joints or splits in the shell body **shall** be satisfactorily sealed to prevent explosives in the joint/split and to prevent hot propellants from reaching the explosive.
- 1.402.028 T When installing a primary charge it **shall** be ensured that no cavity occurs that could cause inadvertent initiation.
- 1.402.029 T In shells equipped with an end screw or base fuze, the charge in the shell **shall** be well filled against the base of the shell.
- 1.402.030 T In shells fitted with a base-bleed unit, any uncontrolled base-bleed combustion **shall not** lead to deflagration or detonation of the warhead.

4.2.3.2 High explosive warheads for rockets and guided missiles

This section covers HE warheads for rockets and guided missiles. Such warheads consist mainly of a casing (sleeve, nose cone) and an HE charge. Designs differ to achieve optimum effect in the intended target. The casing is also designed to withstand calculated stresses during use. The HE charge may be cast or pressed.

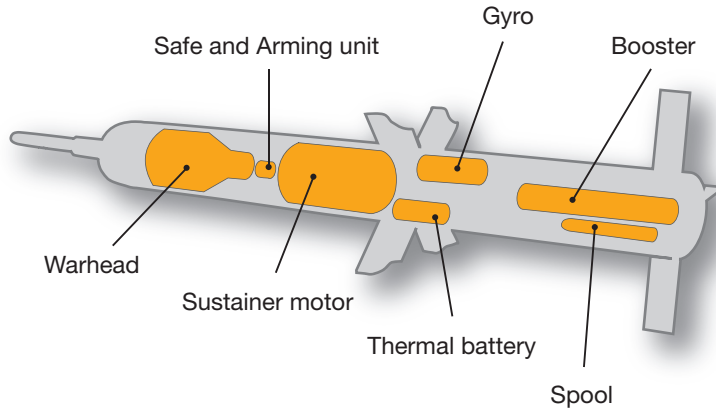

Figure 4:2 Rocket with warhead

A characteristic feature of rocket and missile warheads is that they are usually located adjacent to a rocket motor. Consequently, the safety review must take into account inter alia the likelihood of initiation of the explosive by heat from the burning propellant or by the direct ingress of propellant gases owing to their erosive effect, or because of material defects.

Some projectiles are subjected to high acceleration, such as those employing impulse rocket motors, where all the propellant is fully combusted in the launch tube. In this case the requirements concerning absence of pipes etc. in the HE charge and warhead casing are the same as for tube-launched ammunition as specified in *Section 4.2.3.1* to avoid any possibility of the high explosive settling which could cause premature initiation. Most rocket and missile warheads, however, are not subjected to such an acceleration, which is why the same stringent safety requirements do not need to be applied in respect of the casing, surface texture, or the freedom from pipes and cracks of the HE charge.

Ammunition can be subjected to aerodynamic heating of the warhead in the trajectory or during air carriage phase.

- 1.402.031 T The warhead casing should not consist of separate parts within the zone adjacent to the rocket motor in order to avoid gas leakage.
- 1.402.032 T The HE charge in the warhead should be protected from heat-generating components.

4.2.3.3 High explosive warheads for bombs

This section addresses HE warheads for bombs which herein refer mainly to those that are equipped with fins or equivalent, and are dropped from aircraft to subsequently follow a ballistic trajectory. For bombs that contain devices to guide the bomb to the target or to correct the final phase of the trajectory, the applicable parts of *Section 4.2.3.1* and *4.2.3.2* apply.

Bomb warheads mainly consist of a casing and an HE charge. The casing is sometimes designed to provide fragmentation effect. The casing also has to be designed to withstand calculated stresses during use.

The bomb casing is equipped with a suspension device and fins, and is usually completely filled with high explosive. This may be cast or pressed, or consist of liquid high explosive. The casing may also contain the bomb fuze system. For the fuze the requirements specified in *Section 4.4, Fuzing systems* apply.

A feature of warheads in HE bombs is that they usually contain large quantities of high explosive which means that an inadvertent detonation can cause extensive injury and damage.

Bombs are usually not subjected to high rates of acceleration which is why less stringent safety requirements can be stipulated regarding the structural strength, homogeneity etc. of the explosive charge.

Environmental stress factors such as vibration and aerodynamic heating occur in high-speed flight.

1.402.033 T If the casing consists of separate parts, there **shall** be a sufficiently good seal to ensure that the ingress of moisture or the leakage of explosive does not occur.

1.402.034 T Where separated charges are used the intervening space **shall** be filled with an appropriate filler material.

4.2.3.4 High explosive warheads for land mines

This section includes equipment specific instructions for warheads for land mines, which herein mainly denotes those that are laid manually and those laid by a mechanical minelayer. In addition, the common requirements specified in *Section 4.2.3.1* apply.

For warheads that are ejected or transported to the target zone by some kind of carrier, the relevant parts of previous sections of this chapter apply.

Land mine warheads mainly consist of a casing and HE charge. The casing is sometimes designed to provide fragmentation effect. The casing also has to be designed to withstand calculated stresses during use. In some cases the warhead has no casing, but the HE charge is then reinforced with fibreglass, either homogeneous or surface reinforced.

The casing is usually completely filled by the HE charge which may be cast or pressed. The casing may also contain the mine fuze system. For the fuze the requirements specified in *Section 4.4, Fuzing systems* apply.

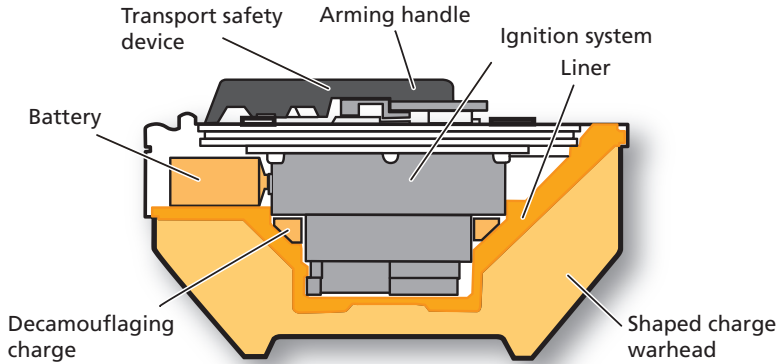

Figure 4:3 Example of a land mine warhead

In terms of safety, warheads for HE land mines are usually characterised by containing relatively large quantities of high explosive, which means that an inadvertent detonation can cause extensive injury and damage.

Land mines are normally not subjected to high rates of acceleration which is why less stringent safety requirements can be stipulated concerning their structural strength, homogeneity etc.

1.402.035 T If the casing consists of separate parts there **shall** be sealing to prevent the ingress of moisture.

1.402.036 T Metal casings **shall** be protected against corrosion.

4.2.3.5 Warheads containing high explosive for depth charges, underwater mines and torpedoes

This section contains object specific requirements for warheads used in underwater mines, depth charges and torpedoes. For small underwater weapons, such as anti-submarine grenades, refer to *Section 4.2.3.6*. In addition, the common requirements specified in *Section 4.2.3.1* apply.

When designing underwater mines that are intended for deployment in peacetime it should be taken into account the possible risk for inadvertent initiation – owing for instance to gas formation in the warhead or collision with a surface vessel or submarine – or lightning/thunderstorm charge even after a long period of deployment.

Warheads for underwater mines, depth charges and torpedoes are designed to provide overpressure effects and consist mainly of an explosive charge, the casing and a space for the fuzing system. Some torpedoes are designed to carry a shaped-charge warhead. The casing is designed for the calculated stresses during handling and the actual launch stresses, but great attention must also be paid to corrosion resistance and resistance to the ingress of water/moisture, both in salt water and in a salt water atmosphere.

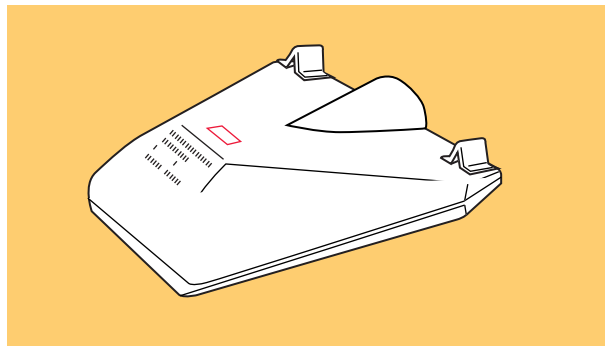

Figure 4:4 Example of an underwater mine

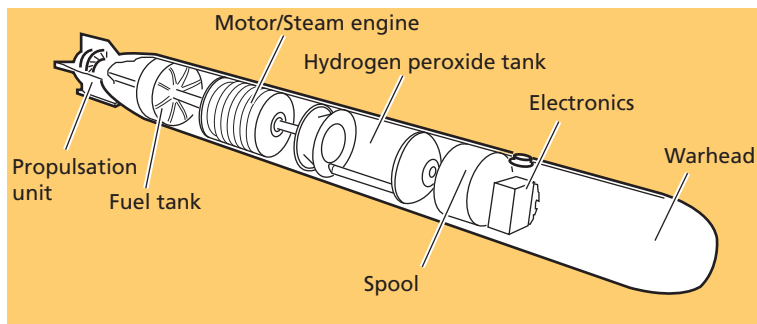

Figure 4:5 Example of a torpedo

4 Ammunition

A characteristic feature of high explosive warheads for underwater mines, depth charges, and torpedoes is that they usually contain extremely large quantities of HE which is why an inadvertent detonation can cause extensive injury or damage. The high explosive may contain aluminium powder and ammonium perchlorate to increase the pressure effect. This generally means that stringent requirements must be stipulated concerning water tightness since ingress of moisture may cause gases to form. In certain cases ventilation must be enabled. These warheads are subjected to lower rates of acceleration than tube-launched ammunition which is why less stringent safety requirements can be stipulated concerning the structural strength of the high explosive, its adhesion, and its freedom from cavities and cracks. However, there is enhanced risk when there are through-cracks in large charges contained in elastic casings or in casings with low structural strength.

Explosives in practice warheads for underwater weapons should be avoided. If the pedagogical nature of the training does not allow total exclusion of high explosives, it is vital that the quantity of any explosive used shall be small enough so that an inadvertent initiation entails a minimum of risk of injury to personnel or damage to equipment. Instead, other types of indication should be employed such as buoys or pyrotechnic spotting charges for smoke or light signals.

1.402.037 T If there is a risk of overpressure in the warhead it **shall** be possible to remove plugs or other seals without risk of injury to personnel, such as during in-service surveillance of ammunition.

1.402.038 T Fuzes that are installed from the outside **shall** form a seal with the casing or have a sealed seat/location.

1.402.039 T Metal casings **shall** be protected against corrosion internally and externally.

1.402.040 T Where separate charges are used, any intervening space **shall** be filled with an appropriate filler material.

1.402.041 T Explosives in warheads **shall**, when adequate sealing cannot be guaranteed, be compatible with surrounding media.

Comment: This should be taken into account even if good sealing can be guaranteed.

1.402.042 T Explosives in warheads should be easy to inspect with respect to environmental impact, such as moisture.

Comment: This especially applies to ammunition that is intended to be used internationally and then returned to Sweden.

4.2.3.6 High explosive warheads for other ammunition

This section states equipment specific requirements for other types of ammunition containing HE charges than those dealt with elsewhere in this chapter. In addition, the common requirements specified in *Section 4.2.3.1* apply. This section addresses HE ammunition that is not readily categorised as having HE warheads designed for tube-launched ammunition, bombs, rockets, guided missiles, land mines, underwater mines, or torpedoes.

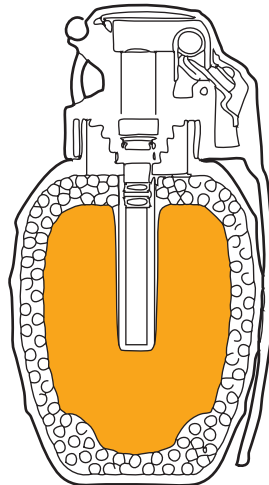

Figure 4:6 Example of a hand grenade

4 Ammunition

Ammunition covered in this section is normally used statically with the exception of for example hand grenades and line charges, which can be deployed either by hand or by means of a rocket. Initiation is either delayed (e.g. safety fuze with detonator or delay detonator) or remotely controlled (e.g. lanyard with percussion cap, rapid or PETN fuze, or electrically).

Examples of such ammunition are hand grenades, mine clearing ammunition, PETN fuzes, cylindrical or prismatic shaped charges and demolition charges such as Bangalore torpedoes and linear charges.

A characteristic feature of such HE ammunition is that it often incorporates high explosive in containers of elementary design or without a casing, and that if a hazardous event occurs can deflagrate or detonate to cause incendiary, fragmentation and pressure effects.

Safety during use is mainly based on regulations, and instructions for use. Refer also to *Section 4.4, Fuzing systems*.

1.402.043 T Ammunition should be such that co-storage and joint transportation with other types of ammunition are in accordance with IFTEX and the 'UN Recommendations on Transport of Dangerous Goods, Model Regulations' can be permitted.

Comment: Choice of packaging can affect the classification.

4.2.4 Pyrotechnic warheads

This section addresses warheads whose main effect is based on pyrotechnic charges. Other warheads incorporating pyrotechnics (e.g. as tracers or as components in priming devices) are addressed in relevant subsections. The same applies to warheads with comparable effect achieved by agents other than pyrotechnic (e.g. instantaneous smoke by ejection of substances that themselves are not explosives). Incendiary warheads containing a charge of high explosive incendiary composition shall be considered as HE warheads from the safety aspect.

Pyrotechnic charges contain pyrotechnic compositions that can be in powder form, granulated to a particular shape, or pressed (with or without a binding agent) to form pellets. They are usually encased in moisture-proof containers. Where appropriate, the casings are resistant and sealed such as for warheads for high explosive tube-launched ammunition, rockets and bombs.

Pyrotechnic warheads can be incorporated in:

- illuminating ammunition used for illuminating the battlefield,
- smoke ammunition for degrading enemy visibility,
- incendiary ammunition,
- signal ammunition, utilising light and/or smoke,
- spotting and practice ammunition simulating real weapon effect.

A characteristic feature of most types of pyrotechnic ammunition is that it often contains flammable pyrotechnic compositions which, when ignited, emit hot combustion products that can cause fire. Depending on the casing, such pressure may arise that rapid deflagration, or even detonation, occurs in which case the casing can burst with subsequent fragmentation effect. Pyrotechnic compositions can be sensitive to shock, especially if composition dust is present or can occur.

There is a risk of friction ignition if such composition dust migrates to, or during manufacture becomes present in, threads or joint surfaces where it may initiate when the fuze is screwed on or off or when subjected to equivalent stress such as bump, shock or vibration. It is of vital importance that pyrotechnic charges are adequately encapsulated to prevent risks of this type. Even cracks in compressed pellets can entail a risk of friction initiation or violent burning if subjected to environmental stress.

Some parts of inadequately mixed compositions may be more sensitive to percussion than normal.

Pyrotechnic compositions that are hygroscopic may change their properties as a result of moisture ingress. Gases may form and create such an increase in pressure that the casing can burst. Escaping gases (such as hydrogen) can form an explosive mixture with air.

4 Ammunition

The ingress of moisture can also entail a risk of spontaneous combustion (e.g. for smoke compositions containing zinc).

Generally, smoke compositions contain inert zinc which does not involve a risk of spontaneous combustion.

Pyrotechnic charges or their combustion products can be toxic, especially smoke charges. Attention must also be paid to ensuring compatibility between the various compositions and the other components in a pyrotechnic warhead. The stability of the compositions used when subjected to various environmental conditions shall also be taken care of.

- | | |
|-------------|--|
| 1.402.044 T | Pyrotechnic ammunition should be designed and the compositions selected such that co-storage with other types of ammunition in accordance with IFTEX and the 'UN Recommendations on the Transport of Dangerous Goods, Model Regulations' can be permitted. |
| 1.402.045 T | The charge shall meet the prescribed moisture content. |
| 1.402.046 T | The charge shall meet the prescribed purity from foreign particles. |
| 1.402.047 T | The pyrotechnic composition used should have good storage stability. |
| 1.402.048 T | Compressed pellets shall meet the prescribed structural strength. |
| 1.402.049 T | Insulation adhesion shall meet the prescribed value. |
| 1.402.050 T | Requirement 1.402.049 T shall be verified by testing, if necessary by destructive testing. |
| 1.402.051 T | Insulation shall be free from cracks, cavities and symmetry deviations. |
| 1.402.052 T | The charge casing shall be sealed. |

4.2.4.1 Pyrotechnic warheads for tube-launched ammunition

This section contains object specific requirements for pyrotechnic warheads for tube-launched ammunition. In addition, the common requirements where applicable, specified in *Section 4.2.3.1* apply.

This section addresses pyrotechnic warheads for illuminating, smoke or incendiary effects (or a combination thereof) used in guns (including signal pistols). Such warheads mainly consist of a shell body (cargo shell) which is designed to withstand the high pressure and subsequent high acceleration and, where appropriate, spin and spin acceleration for the weapon specified, together with a pyrotechnic charge (or charges).

Additionally, in most cases there are one or more parachutes, spin brakes and bourrelets. Effect is achieved in the form of illumination, smoke screen, setting the target on fire, or by signal effect.

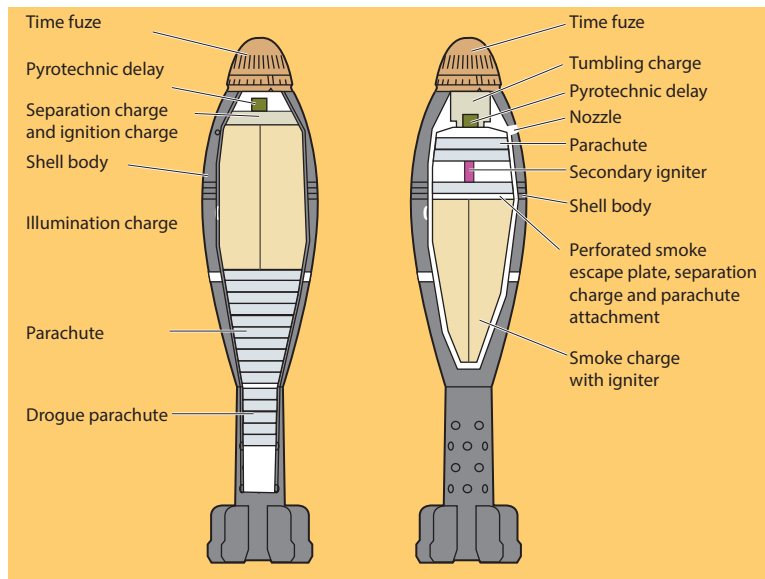

Figure 4:7 Example of a shell for illuminating and smoke effect

A characteristic feature of pyrotechnic warheads for tube-launched ammunition is that they are subjected to high pressures and temperatures by the propelling charge during the barrel phase. In most cases the shell body is provided with an expellable base, which is expelled together with the pyrotechnic charge at a predetermined point in the trajectory. Unsatisfactory sealing of the base or material defects that may allow the ingress of hot propellant gases can cause a hazardous event if the charge is ignited in the barrel.

Furthermore, the structural strength of the charge and the charge casing is vital from a safety aspect, because if the charge disintegrates during acceleration, or if there is loose composition dust present, friction initiation and an uncontrollable burning process may occur.

1.402.053 T The base of the shell **shall** be completely sealed against hot propellant gases, moisture etc. and against composition dust.

1.402.054 T At final assembly the charge **shall** have the correct moisture content.

Comment: If necessary the charge may need to be dried before final assembly.

4.2.4.2 Pyrotechnic warheads for rockets and bombs

This section contains object specific requirements for pyrotechnic warheads for rockets and bombs. In addition, applicable sections of the common requirements stated in other sections pertaining to warheads for rockets and bombs also apply.

This section addresses pyrotechnic warheads for illuminating, smoke or incendiary effect, or combinations of these, for rockets and bombs. The warheads mainly consist of a casing and a charge (or charges) containing pyrotechnic composition, and a parachute or equivalent. In rockets the warhead is integrated with the rocket motor (or motors) while bombs are generally ballistic units that are dropped onto the target from aircraft.

A characteristic feature of pyrotechnic warheads for rockets is that they are usually located adjacent to a heat-generating rocket motor. The safety review must therefore take into account the risk for ignition of the pyrotechnic composition by the ingress of hot propellant gases or by heating the dividing wall. Such ingress of propellant gases can occur through defective sealing, material defects or erosion.

Most warheads for rockets and bombs are not subjected to high rates of acceleration which is why stringent requirements do not need to be applied for the structural strength of the charge. However, loose composition dust in threads or joint surfaces may ignite by friction when the fuze is inserted or removed, or if there is shock stress. Aerodynamic heating of the warhead can occur in airborne ammunition during high-speed flight.

1.402.055 T The dividing wall (partition) between the warhead and rocket motor **shall** be sealed and insulated so that ignition of the composition does not occur through the ingress of propellant gases or by heat transmission.

1.402.056 T At final assembly the charge **shall** have the correct moisture content.

Comment: If necessary the charge may need to be dried before final assembly.

4.2.4.3 Other pyrotechnic warheads

This section contains object specific requirements for other pyrotechnic systems than warheads in tube-launched, rocket or bomb ammunition. In addition, the common requirements specified in *Section 4.2.3.1* also apply.

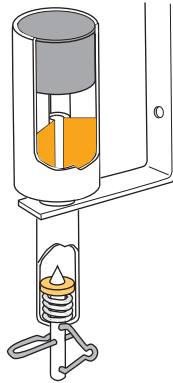

Figure 4:8 Example of a trip flare

This section addresses pyrotechnic systems with illuminating, infrared (IR), smoke, incendiary or acoustic effects, or combinations thereof. Such ammunition is usually used statically with the exception of smoke hand grenades and tracers, for example, and is ignited either with a delay (e.g. a fuze) or from a distance (lan-yard, trip-wire or by electric triggering).

The following are examples of such pyrotechnic ammunition: trip flares, smoke hand grenades, smoke candles, electron incendiary bombs, spotting rounds, thunder flashes and burst simulators.

A characteristic feature of the pyrotechnic ammunition listed above is that it contains a pyrotechnic charge inside a container of elementary design (waxed paper, plastic or sheet-metal containers), and that it constitutes a fire hazard and can provide pressure and/or fragmentation effects. Safety is based mainly on safety regulations and regulations for use.

There are no specific requirements except for the requirements stated in *Section 4.2.4*.

4.2.5 Other warheads

This section contains object specific requirements for other warheads than those containing high explosives and pyrotechnic compositions. In addition, applicable parts of *Section 4.2.1*, *4.2.2*, *4.2.3* and *4.2.4* also apply. This section also addresses warheads with payloads consisting mainly of non-explosives. Warheads may however contain explosives for ejecting such items as instantaneous smoke, radar-reflecting chaff, radio jamming devices, meteorological sondes, etc. Such warheads can also contain other substances that are toxic, corrosive or inflammable, possibly with the capacity for spontaneous ignition on contact with air or water (moisture) such as titanium tetrachloride, chlorosulfonic acid (a smoke-producing agent) or phosphorus. Such substances must be confined in such a way that their harmful effects are prevented. The ammunition addressed in this section need not contain any explosives (such as napalm and gas for training purposes).

1.402.057 T Applicable parts of the requirements specified for pyrotechnic charges in *Section 4.2.4* shall apply.

4.3 LAUNCHING AND PROPULSION SYSTEMS

This section specifies the common requirements for launching and propulsion systems, referred to below as propulsion devices. In addition, the equipment specific requirements stated in the relevant subsection for the various types of propulsion devices also apply.

The purpose of propulsion devices in ammunition is to produce sufficient impulse to transport the warhead to the target. Examples of propulsion devices are charges for tube-launched weapons, which provide projectiles with the correct muzzle velocity, reaction engines for the propulsion of missiles and rockets and charges to launch countermeasures.

For barrel launched munitions only solid propellants are used. Rocket engines use solid propellants as well as single, double or triple base liquid propellants. Air-breathing rocket engines use low-oxidiser propellants (in ramjet and ram rocket engines/motors), solid fuels without oxidiser and liquid fuels (ordinary ramjet and turbojet engines).

Propellants, like other types of explosives, are characterised by a very rapid generation of energy irrespective of their surroundings. On the other hand, heat generation per unit mass is low (approximately 10% of the heat generated compared with when the corresponding quantity of petrol/gasoline in air).

Ignition of propellants is achieved by using various types of priming devices containing an initiator that is initiated mechanically or electrically, or by some other type of energy supply. The priming device usually contains a pyrotechnic booster charge adjacent to the initiator (e.g. percussion cap, electric primer) to ensure rapid, reproducible ignition of the propellants. Artillery primers in cartridge cases, base-bleed initiators and rocket engine initiators are examples of such priming devices.

Gas generators use solid or liquid propellants. These are designed to produce gas flow under pressure and are used for various purposes in ammunition, such as to pressurise fuel and oxidiser tanks in liquid fuel rocket engines etc. Gas generators are used as power sources for subsystems in guided missiles and torpedoes, or as devices in projectiles for reducing drag, so-called base-bleed units.

From a safety point of view it should be noted that propellants can be inflammable, highly reactive, toxic, and explosive. Combustion speed increases usually with pressure, i.e. the casing conditions. If the rise in pressure is uncontrolled there is a risk of a hazardous event. Inadvertent initiation can occur through friction, discharge of static electricity, heating to ignition temperature, or by inadvertent actuation of the priming device (by impact, shock, heat or electric fields). Additionally, propellants can be susceptible to deterioration through ageing so that the ignition temperature becomes lower or chemical instability arises for example.

Several countries are developing propellants that are less sensitive to fire and bullet attack. Such propellants are designated LOVA propellant (Low Vulnerability).

4.3.1 Environment for launching and propulsion systems

Examples of the consequences of the environment's mechanical impact include cracks, debonding/separation, formation of propellant dust, damage to propellant insulation or other defects that considerably increase the burning surface, may occur in propelling charges. This means that the pressure during combustion will be higher than that for which the ammunition casing is designed.

The following are examples of the consequences of physical and chemical stress from the environment:

- If stored at high temperature and/or in high humidity there is a risk that the rate of burn of the propelling charge may be affected so that an excessive pressure arises. This applies particularly to unbonded charges and can, in unfavourable cases for example, result in blockage of the exhaust nozzle in rocket motors or base-bleed units by charge particles that have debonded/separated.
- When using a case-bonded/cast charge a permanent deformation may be induced because of differences in the coefficients of expansion between the casing and the charge. This can – in some cases after a long duration – result in cracks in the charge (relaxation until fracture) or cause debonding between the

charge and its insulation. The risks are enhanced when the casing is subjected to pressure at initiation. Risks may also arise as a result of temperature variations.

- Reactions in the propellant, or between the propellant and other materials (compatibility problems), can change the properties of the propellant itself. An example of this is decay in the rheological properties which can lead to the formation of cracks in the propellant when used at low temperatures. Another example is degraded chemical stability which, in severe cases, can lead to self-initiation of the propellant. A further example involves changes in internal ballistic properties, which can cause the combustion process to differ from what is intended, particularly at high or low temperatures. Furthermore, the propellant can affect other materials, such as the igniter cup, causing the material to embrittle and rupture.
- Liquid fuel propellants with a higher coefficient of expansion than the surrounding fuel tank casing can, when overheated, rupture the casing or the integral bursting discs, whereby the propellant can be expelled into the reaction chamber and/or the surroundings.
- Propellant devices with electrically non-conducting casings, and propellants containing metallic powders such as aluminium, can be subject to inadvertent initiation caused by electrostatic discharge. Electrical charging of the casing can occur during use. This applies specifically at low humidity. The field emanating from the electric charge can be amplified in the propellant and cause discharge between the metallic grains thus causing inadvertent initiation. A number of accidents caused by ESD (electrostatic discharge) have occurred in the USA. All have occurred in systems containing large charges (Pershing, Peacekeeper).

4.3.2 Joint requirements for launching and propulsion systems

- 1.403.001 T** The design of, and materials in, a propelling charge casing **shall** be selected so as to ensure that the casing resists all specified loads without exceeding the permissible deformation or stress.
- 1.403.002 T** Adjacent materials, and materials in the propellant, **shall** be compatible. These materials may comprise internal protective paint, sealing agents, insulation materials, combustion catalysts, wear protectants, etc. Refer also to requirements *1.202.002 T*, *1.202.003 T* and *1.202.004 T*.
- 1.403.003 T** When using hardened steel the material and heat treatment chosen **shall** be such that neither hydrogen brittleness nor detrimental corrosion occurs.
- 1.403.004 T** The propelling charge **shall** be of a type, quality, and size to ensure that the required safety margin for permissible maximum pressure in all specified environments is not exceeded.
- Comment:* The requirement applies to both tube-launched ammunition (limited by the strength of the barrel) and rocket motors (limited by the strength of the casing), see also the guideline text in the first paragraph in *Section 4.3*.
- 1.403.005 T** The propulsion force development and pressure–time curves **shall** be reproducible within the stated requirement specification.
- 1.403.006 T** Propelling charge should be designed to minimise fragments propelled rearwards from e.g. the base plate or nozzle plug.
- 1.403.007 T** The safe separation distance/time **shall** be established for all propulsion systems for the most unfavourable operating conditions. Refer also to requirement *1.402.017 T*.

1.403.008 T	Metal additives, if any, shall not be able to block the exhaust nozzle.
1.403.009 T	The propelling charge casing shall be sealed as required.
1.403.010 T	The propelling charge casing shall withstand handling throughout its service life.
1.403.011 T	The composition of the propellant should be such that itself, its components and its combustion products are of minimal toxicity and have as little environmental impact as possible. This applies to manufacture, use, clearance of UXO and disposal. <i>Comment:</i> See also <i>Section 4.1.4</i> .
1.403.012 T	The design should facilitate disassembly (e.g. for upgrading, in-service surveillance and disposal).
1.403.013 T	The propulsion device in its tactical application should not detonate when subjected to the specified attack from bullets, fragments etc. <i>Comment:</i> This requirement is part of the IM requirements defined in STANAG 4439.
1.403.014 T	Requirement <i>1.403.013 T</i> should be verified by testing.
1.403.015 T	The propulsion device in its tactical application should not detonate if subjected to fire. <i>Comment:</i> Compare also general IM requirements.
1.403.016 T	A fuel fire test should be performed to verify requirement <i>1.403.015 T</i> .

4.3.3 Propulsion devices in tube-launched ammunition

This section contains equipment specific requirements for propellants in the form of solid propellant for tube-launched ammunition. In addition, the common requirements specified in *Section 4.1* also apply.

Nitrocellulose-based propellants are normally used in tube-launched ammunition. The following factors must be taken into account when designing a propelling charge: the size of the combustion chamber, length of the barrel, dynamic strength of the barrel (elasticity), mass of the projectile, driving band force, method of initiation, and the temperature. The pressure development is dependent on these factors as well as on the type of propellant and the size and shape of the burning surface.

Propellant dimensions are usually such that the propellant has burnt out before the projectile exits the muzzle, since the aim is to achieve low dispersion of velocity and to minimise the muzzle flash.

Propellants are normally encased either in fabric (i.e. bag charge), or in a cartridge case or separate case to form a propelling charge of designated type and dimensions.

Bag charges are used where an incremental/modular charge system is required, such as for howitzers and mortars. Bag charges can then be used in combination with separate charge cases, made of metal or plastic, to facilitate simultaneous loading of the shell and propelling charge.

Small arms and automatic weapons, for example, use unitary ammunition with a single propelling charge in a metal cartridge case.

Combustible cartridge cases are also available, consisting mainly of nitrocellulose. The combustible case burns together with the propellant.

Priming devices normally consist of an artillery detonator (electrically or mechanically actuated), and usually pressed into the base of the cartridge case. It may be short or can extend through a large section of the loading chamber in order to achieve simulta-

4 Ammunition

neous initiation of the entire propelling charge. Bag charges (modular charges) often have a booster charge of black powder or finely granulated porous propellant attached in order to achieve the same effect.

Artillery primers are used as priming devices in howitzers that use bag charges. The artillery primer is inserted into the breech mechanism of the weapon.

The propulsion agent for small arms ammunition is ignited by a percussion cap or equivalent.

ETC (electro-thermal-chemical launching) is being studied for possible introduction into future weapon systems. This technology is providing opportunities for increased muzzle velocity of the weapon. More stringent requirements will thereby be applied for heat resistance and structural strength in the combustion chamber and barrel. Considerably higher combustion temperatures and pressures will be achieved.

The rapid discharge of large quantities of stored energy in the capacitor bank of the weapon increases risks in the form of high electric and magnetic fields and currents.

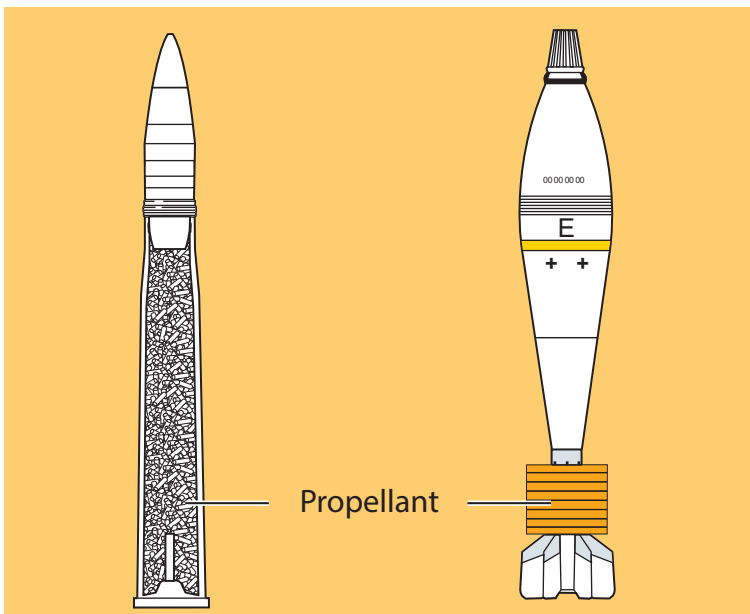

Figure 4:9 Examples of propelling charges

Characteristics of propelling charges are that they are air-independent, and that their rate of combustion depends, in part, on the propellant type and the shape of the powder grain.

Some propellants, under certain circumstances, can be brought to detonation. Factors that tend to increase their proneness to detonation are strong tamping/confinement, small particle size, high rate of porosity, high nitroglycerine content and large charge quantities.

In addition to the hazard initiation stated in *Section 4.3*, (next to last paragraph) accidents can occur if the incorrect charge (incorrect type of propellant, incorrect dimension or quantity) is used, or if an incorrect or defective projectile is used.

1.403.017 T Within the permitted temperature range the propelling charge **shall** produce a pressure (MOP) that is lower than the permitted maximum value for the barrel and shell.

Comment: In the design of the ammunition the pressure definitions and procedures stated in STANAG 4110 must be applied.

1.403.018 T For recoiling barrels the combustion of the propelling charge should be designed so that the charge has burnt out before the projectile exits the muzzle. This is to avoid giving rise to back-flash/secondary combustion when the weapon's breach is opened.

1.403.019 T Maximum fire engagement with regard to the risk of cook-off when firing is interrupted for a barrel at its maximum operating temperature **shall** be determined.

Comment: Refer also to requirement 1.302.029 T.

1.403.020 T The cartridge case **shall** seal against the chamber seat so that unpermitted gas leakage does not occur.

1.403.021 T When using percussion caps in artillery primers etc., the impact surface **shall** be countersunk so that the risk for inadvertent initiation during use is minimised.

4.3.4 Propulsion devices and gas generators for rockets, guided missiles, unmanned vehicles, torpedoes, etc

This section contains equipment specific requirements for propulsion devices and gas generators used in rockets, guided missiles, torpedoes, etc. A common factor of these devices is that they all contain propellants that constitute hazard factors (fire, explosion or toxic hazards). These devices are incorporated in various types of propulsion systems, and can be subdivided into the following three groups:

- reaction engines (see *Figure 4:10*),
- gas generators,
- propulsion devices for torpedoes.

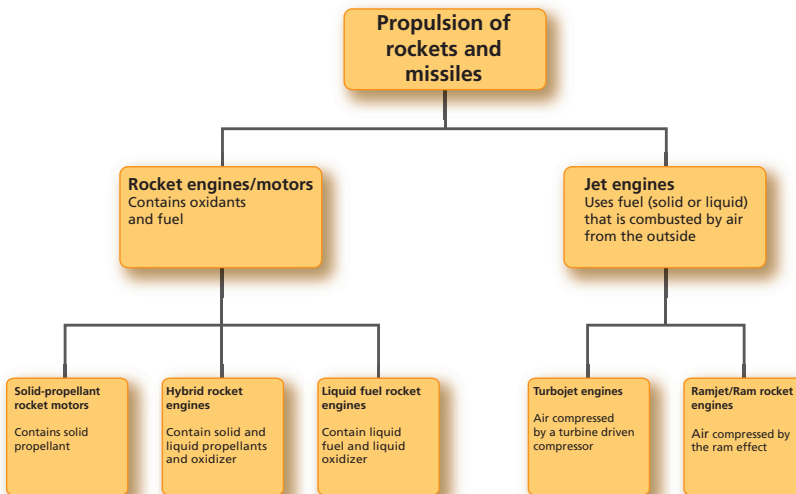

Figure 4:10 Subdivision of rocket and missile propulsion

4.3.4.1 Solid propellant rocket motors and gas generators

Rocket motors and gas generators use solid propellants confined in a casing incorporating one or more nozzles and the necessary initiating devices.

As the propellant burns, hot gases are formed that exit through the nozzle.

Because the rate of combustion is dependent on the temperature of the propellant, the pressure is usually higher in a hot engine than in a cold one.

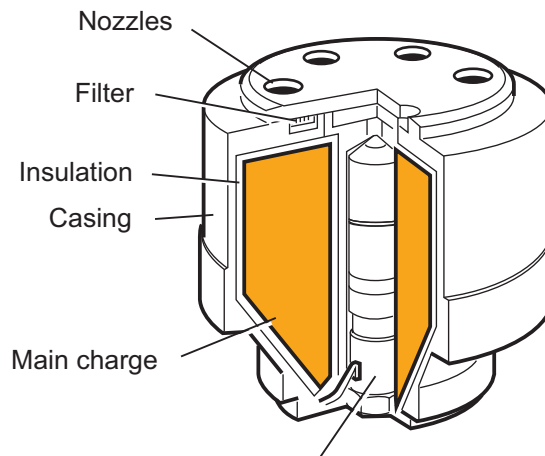

Figure 4:11 Solid propellant gas generator

In a solid propellant gas generator the pressure may be controlled by releasing the gas flow that is not consumed for the designed purpose through one or more valves.

The charge(s) in a solid propellant rocket motor is/are usually designed according to one of two main principles:

- unbonded in the engine casing, for example in the form of tubes or rods, see *Figure 4:12*,
- case-bonded by casting propellant directly into the engine casing which is provided with an internal layer of bonding and insulating material, see *Figure 4:13*.

Those sections of the inner walls of the engine casing that are subjected to hot combustion gases during combustion are usually protected by insulation.

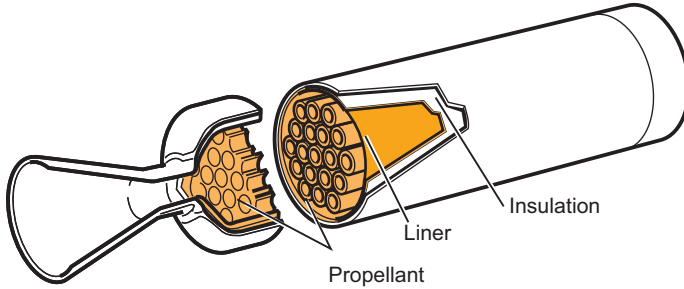

Figure 4:12 Unbonded tubular propellant, all-round combustion

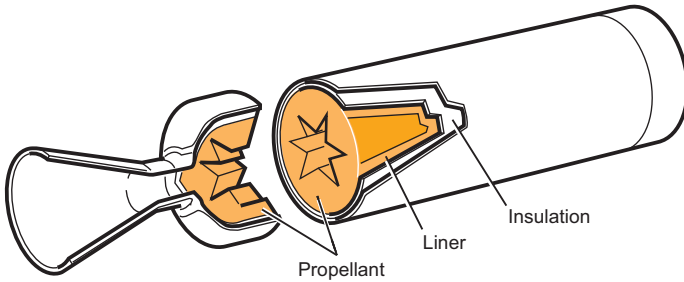

Figure 4:13 Case-bonded charge, combustion in the propellant channel

Defects in propellant motors, such as cracks in the propelling charge(s) and/or debonding between the charge and the insulation, may, due to the enlargement of the burning surface, lead to such high pressure that the casing ruptures. Defective propellant or insulation, may therefore, depending on the application, be a single fault which may lead to a catastrophic event. In these cases, for example if a missile is uploaded onto an aircraft, it is important that the design and production control are such that established failure rates in the safety analysis are not exceeded.

High pressure can also result from the unstable combustion of propellant owing to high frequency pressure oscillations in the motor.

Rupture or leakage at normal operating pressure can also occur owing to degradation of the strength of the casing material, or because of corrosion or defects in the internal heat insulation.

Usually the propellant dies down if the casing ruptures, but it can be reignited if it for instance comes into contact with hot surfaces.

1.403.022 T Propulsion devices should be designed such that the pressure vessel does not burst or detonate as a result of the impact of shrapnel from fragment-forming ammunition (or equivalent).

Comment: This requirement is part of the IM requirements defined in STANAG 4439.

1.403.023 T Propulsion devices should be designed such that if the pressure vessel bursts a minimum of dangerous fragments are formed.

1.403.024 T Propulsion devices **shall**, with regard given to transport and storage, be designed such that a specified fire does not cause uncontrolled flight.

1.403.025 T Propulsion devices containing propellants with metallic powder **shall** be analysed with regard to risks in the event of electrostatic charging.

4.3.4.2 Liquid propellant rocket engines and gas generators

Rocket engines and gas generators using liquid propellants are based on propellants usually in hermetically sealed containers (tanks). Propellants may be made of one or several components. Each component is stored in a separate tank. Combustion usually takes place spontaneously when the propellants are mixed in:

- the tank system,
- the feed system,
- the reaction chamber,
- the exhaust nozzle.

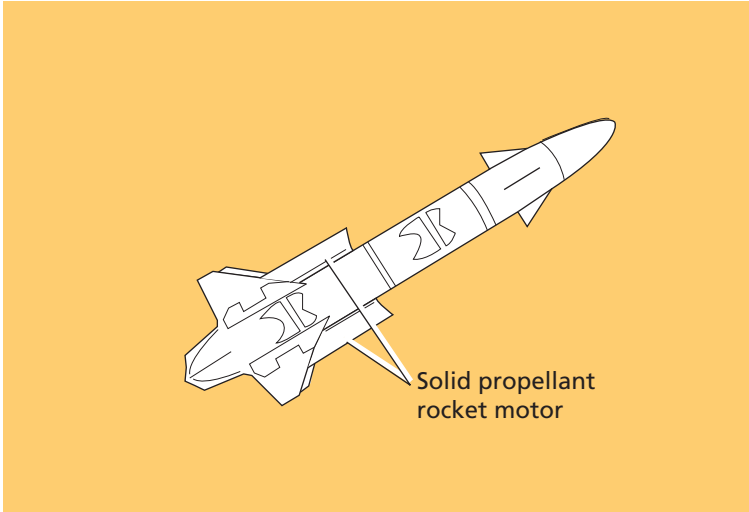

Figure 4:14 Example of solid propellant rocket motor (booster)

Propellants are often highly reactive and toxic. Liquid fuel rocket engines usually contain propellant gas generators with relevant initiating devices. The following hazardous events can occur:

- poisoning or injury to the skin upon contact with propellant that has leaked out in liquid or gaseous phases,
- fire in the event of contact between propellant that has leaked out and combustible or catalytic substances,
- spontaneous or delayed reaction in the event of contact between propellants.

1.403.026 T Requirements 1.403.015 T, 1.403.016 T, 1.403.022 T and 1.403.023 T shall apply.

1.403.027 T The tank system shall be designed such that direct contact between propellants cannot occur inadvertently.

1.403.028 T Tanks for propellants shall have adequate space for the expansion of the liquids.

1.403.029 T Leakage of propellants shall not cause the engine to start.

1.403.030 T Leakage of propellants shall not cause the pressure vessel to burst.

4.3.4.3 Jet engines

Turbojet and ramjet engines usually use liquid fuel, but ramjet engines can also use a solid fuel charge located in the combustion chamber of the engine. Missiles that have liquid fuel engines are usually kept in storage with their fuel tanks filled.

Vehicles powered by turbojet engines can be air or ground launched (or launched from ships). In the latter case one or more booster rocket motors are used that are jettisoned after burnout. Turbojet engines are normally started after the weapon is released or launched. A special safety aspect concerning turbojet engines is that the fuel can cause fuel fire through leakage or inadvertent fuel feed.

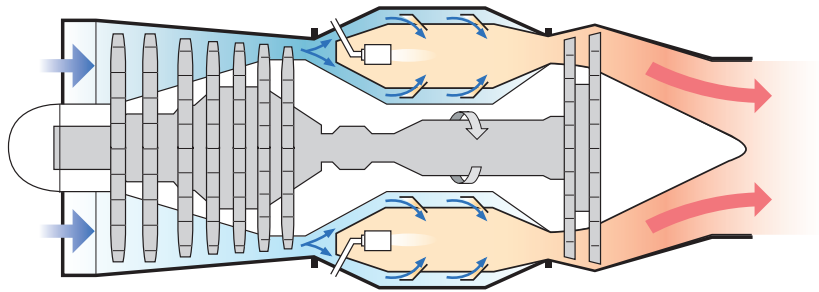

Figure 4:15 Turbojet engine

Vehicles powered by ramjet engines are normally accelerated to approximately twice the speed of sound to achieve satisfactory ramjet engine function. This is generally achieved by using a propelling charge in the combustion chamber of the ramjet engine (i.e. an integrated booster). The booster nozzle located in the ramjet engine exhaust nozzle is jettisoned after burnout, and either the front end of the combustion chamber is opened or special sealing elements are ejected to enable air to enter for the ramjet engine to start. The booster exhaust nozzle can be eliminated in certain cases by designing the propelling charge in a specific way (a so-called nozzleless booster).

From the safety aspect an integrated ramjet engine is characterised – apart from the risk of fuel fire – by the same hazards as those inherent in solid propellant rocket motors owing to the propellant located in the combustion chamber. Other hazards that

must also be taken into account with both types of engines are those that arise when engine parts such as intake and exhaust covers, rocket motor exhaust nozzles, and separate burnt-out booster rocket engines are discarded after launch.

1.403.031 T Requirements *1.403.013 T*, *1.403.015 T*, *1.403.016 T* and *1.403.022 T* shall apply.

1.403.032 T The quantity and size of discarded parts (debris) at the start of ramjet function should be minimised.

1.403.033 T The number of components containing pyrotechnic or explosive charges should be minimised.

4.3.4.4 *Ram rocket engines*

A ram rocket engine consists of a gas generator in which a gaseous fuel is generated, and an afterburner where the fuel is burnt after mixing with air from the atmosphere.

The gaseous fuel is generated through combustion or pyrolysis of a solid propellant.

A ram rocket engine usually has a solid propellant rocket charge located in the afterburner to achieve the required flight velocity in the same way as an integrated ramjet engine. It has a similar system of sealing elements in the front end near the air intake, and a propellant rocket nozzle aft that is jettisoned when the propellant has burnt out. The solid fuel (i.e. propellant with a large excess of fuel) in the gas generator can be initiated and be burning already during the rocket engine phase, thus contributing in a minor way to the mass flow and thereby to the thrust.

However, it is more usual to have the airway between the gas generator and afterburner closed during this phase. At transition, that is when the boost phase is over and when the duct between the gas generator and the afterburner is open, the seal in the air intake is opened at the same time. The gas generator is initiated by its own igniter and begins to produce gas in the afterburner where it mixes with incoming air to be subsequently ignited by the afterburner igniter.

From a safety aspect, ram rocket engines are equivalent to solid propellant rocket motors and gas generators, as well as ramjet engines.

1.403.034 T Requirements 1.403.013 T, 1.403.015 T, 1.403.016 T, 1.403.022 T, 1.403.032 T and 1.403.033 T shall apply as should requirement for ram rocket engines.

1.403.035 T Fire tests for verification of requirement 1.403.015 T shall be carried out for ram rocket engines.

4.3.4.5 *Propulsion devices for torpedoes, self-propelled mines, and torpedo mines*

There are two types of energy platforms for propulsion of torpedoes:

- Thermal system for generating propulsion gas for a thermal motor. Currently Swedish torpedoes use high-test peroxide, HTP, with a concentration of 85% (Swedish: “VP 85”) as an oxidation agent and primarily paraffin is used as fuel.
- Electrical energy stored in rechargeable or thermal batteries and an electric motor for propulsion.

Propulsion devices for Swedish thermal torpedoes are based on piston engines that are driven by high-pressure steam from a steam generator. To start the engine, compressed air or gases from a solid propellant gas generator may be used.

The steam generator is in principle a combustion chamber in which fuel and an oxidiser react while heat is generated. At the same time an appropriate quantity of water is injected so that the propellant gas for the engine consists of dry high-pressure steam mixed with combustion products, usually carbon dioxide, as well as nitrogen in the case of air propulsion.

Propellants are stored in separate tanks. Compressed air is used as an oxidiser as well as for pressurising the propellant tanks.

4 Ammunition

The hazard factors that apply to propulsion devices with the propellant combinations of ethyl alcohol/air and paraffin (kerosene)/air are the same as those that apply to liquid fuel rocket engines and gas generators (see that section). The instability and powerful oxidising effect of highly concentrated hydrogen peroxide, HTP (Swedish: “VP85”), constitutes the most significant hazard factor in systems where it is used as propellant.

If highly concentrated hydrogen peroxide leaks out and comes in contact with organic/combustible material, these materials can ignite spontaneously and the fire process can become fast and powerful. If highly concentrated hydrogen peroxide comes into contact with catalytic material, a reaction occurs which releases large amounts of energy and oxygen. Highly concentrated hydrogen peroxide that has been heated and converted to vapour is explosive.

More information about properties and risks with highly concentrated hydrogen peroxide as well as instructions and requirements regarding handling, transport and more can be found in *HANDBOK VÄTEPEROXID*, M7780-252981¹.

In smaller torpedoes electric motors are often used for propulsion.

Electrically propelled torpedoes, self-propelled mines, and torpedo mines can be equipped with primary or secondary (rechargeable) batteries. Torpedo batteries have very high energy content, so risk factors such as gassing and short-circuiting must be taken into account with regard to design and use. Contact between battery acid, and other substances used in the explosives, and the warhead can lead to hazard initiation.

1. Swedish MANUAL for HYDROGEN PEROXIDE (not available in English).

- 1.403.036 T Requirements 1.403.005 T, 1.403.015 T, 1.403.016 T, 1.403.022 T, 1.403.023 T, 1.403.027 T and 1.403.028 T **shall** all be applied as shall-requirements for torpedo systems.
- 1.403.037 T Water leakage or battery failure **shall not** lead to the inadvertent start of the torpedo.
- 1.403.038 T Torpedoes **shall** be designed in such a way that any inadvertent contact between battery acid and explosives does not occur.
- 1.403.039 T Short circuits which can lead to a battery explosion **shall not** be able to occur.
- 1.403.040 T Explosive gases formed during the self-discharge or charging of batteries **shall** be ventilated away and/or disposed of in order to avoid initialisation occurring.

4.3.4.6 *Systems for highly concentrated hydrogen peroxide*

Hydrogen peroxide (H_2O_2) is often used as a bleaching agent in industry or for, for example, teeth whitening. Higher concentrations of hydrogen peroxide are corrosive and oxidizing.

For technical use, hydrogen peroxide is available in concentrations of 30–70%. The most extensive use of hydrogen peroxide in Sweden is industrial bleaching of pulp.

Hydrogen peroxide with a concentration above about 80% can also be used as a fuel for rockets and turbines. The mode of operation is that hydrogen peroxide under pressure may decompose over a catalyst, which may, for example, consist of silver mesh, to hot oxygen and water vapour. The hot gas mixture gives rise to a reaction force when it passes at high speed through a rocket nozzle or a turbine. For example, 85% hydrogen peroxide is used as an oxygen carrier for the engines in the Swedish heavy torpedoes.

Highly concentrated hydrogen peroxide is a strongly oxidizing, unstable compound that decomposes into oxygen and water/water vapour. The decomposition takes place exothermically, i.e. during the release of heat where the decomposition rate is temperature and material dependent. This means that elevated temperature or contact with catalytic materials has a significant effect on the decomposition rate. Highly concentrated hydrogen peroxide that comes into contact with, for example, liquid fuels or organic solvents can give rise to rapid fire processes or explosions, especially if it occurs in simultaneous contact with catalytic materials. These properties mean that there are risks that need to be considered with regard to handling, transport, storage and use of highly concentrated hydrogen peroxide.

- 1.403.041 T Highly concentrated hydrogen peroxide (HTP) **shall** meet quality requirements and undergo regular inspections specified in *HANDBOK VÄTEPEROXID*, M7780-252981.
- 1.403.042 T HTP tanks **shall** be equipped with adequate relief and drainage devices.
- 1.403.043 T Materials in HTP tanks **shall not** contain catalytic substances that can lead to a reaction by HP.
- 1.403.044 T Spaces in buildings or on board vessels where HTP or HTP-filled torpedoes are handled or stored **shall** be designed in accordance with the instructions and requirements in *HANDBOK VÄTEPEROXID*, M7780-252981.
- 1.403.045 T Materials and components included in systems that store or consume HTP or handle the drainage of HTP **shall** be designed in accordance with the instructions and requirements in *HANDBOK VÄTEPEROXID*, M7780-252981.
- 1.403.046 T HTP **shall** meet quality requirements and undergo regular inspections specified in *HANDBOK VÄTEPEROXID*, M7780-252981.

4.4 FUZING SYSTEMS

The following sections apply to all fuzing systems that are designed to initiate warheads or propelling charges.

The requirements in STANAG 4187 more or less fulfil the requirements specified in this chapter.

For electrical or laser initiation of propulsion devices for rockets and missiles, STANAG 4368 can be used as support for setting requirements.

For fuzing systems for land mines and ‘other ammunition’, i.e. hand grenades, support for requirements can be obtained in STANAG 4497 (“Hand Emplaced Ammunition”).

Warheads and propulsion devices must be initiated by a fuzing system if they are to function as intended. Hence it follows that the safety of the fuzing system is a decisive factor in the safety of the entire weapon system. The fuzing system therefore has its own safety system whose task is to prevent inadvertent initiation throughout all phases in the life of the ammunition with the necessary degree of safety.

The integral safety system of a fuze may contain one or more mutually independent safety features. Each safety feature is subject to one or more arming conditions, each of which must be satisfied for the fuze to arm. It is necessary for all the safety features to be removed to enable the warhead to be initiated.

The more safety features that prevent initiation or transmission in an explosive train at any given stage, the greater is the degree of safety against inadvertent initiation. On the other hand, a large number of safety features can degrade the reliability of the fuzing system with regard to its intended function. This means that the design of a fuzing system must seek a balance between adequate safety as opposed to inadvertent initiation and high functional probability. High functional probability is essential in order to meet the need for effect, and is increasingly important today in the light of the growing demands to, as far as possible, prevent the occurrence of unexploded ordnance (UXO).

4 Ammunition

The principal element of a fuzing system consists of one or more transmission safety devices, the design and location of which are dependent on the method of initiation. There are two groups of transmission safety devices *Figure 4:16* and *Figure 4:17*):

- Transmission safety devices for systems with a so-called out-of-line explosive train (safety device). The explosive components in the explosive train are separated by a mechanical interrupter.

The explosive train is initiated by a detonator when it receives the signal to initiate. The fuze generally contains a detonator with a sensitive explosive.

- Transmission safety devices for systems with a so-called in-line explosive train. There is no mechanical interrupter between the explosive components of the explosive train. The transmission safety device can be electrical (circuit breaker) or optical, for example.

The explosive train is initiated by a detonator when it receives the signal to initiate. The fuze generally contains an electric detonator which requires an ignition voltage of at least 500 V and secondary explosives (explosives that are approved for use after an interrupter).

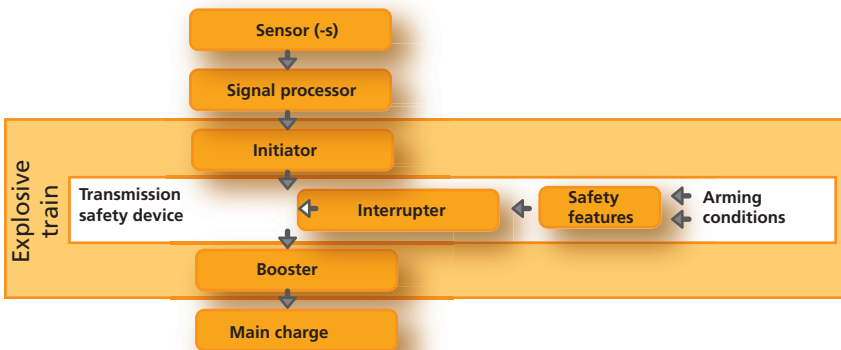

Figure 4:16 Fuzing system with interrupted explosive train ('out-of-line')

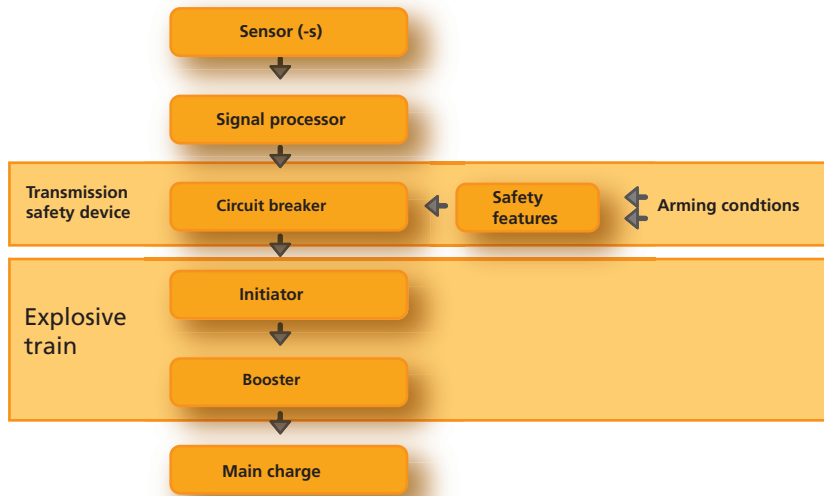

Figure 4:17 Fuzing system with uninterrupted explosive train ('in-line')

When all requirements for the arming process cannot be met, such as when environmental conditions are not available, the safety level can be achieved in certain cases by enabling the fuzing system – or an essential part thereof – to be assembled/installed immediately before use.

Electric fuzing systems have become increasingly widely used among other things due to the increasing use of electronics in sensors and signal processing. These systems can be sensitive to electromagnetic interference which can cause inadvertent initiation. Moreover, it is often difficult to predict the presence and propagation of electric energy. During the safety analysis of the fuzing system, it is therefore often necessary to take into account the design of the entire weapon system in question and its safety features.

Total safety when using a fuzing system is based on two factors: firstly, very carefully considered technical solutions and, secondly, instructions on how to use the system. Together these two factors shall give a tolerable safety level.

When dealing with risks, the aim shall be (through technical design) to minimise or completely eliminate a risk and only when necessary rely on operating instructions.

Requirements governing the need for safety features in a fuzing system must, to a large extent, be related to the severity of the hazard and the related probability.

To understand the concepts of risk and safety related to indirect fire, see *Figure 4:18*.

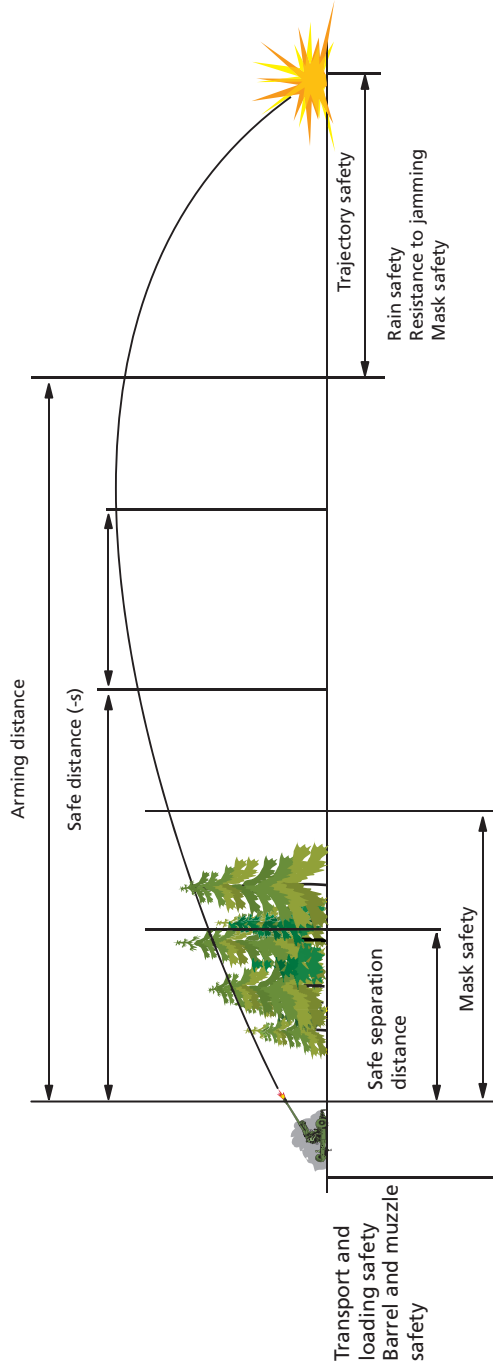

Figure 4:18 The safety concepts

4.4.1 Environments for fuzing systems

Certain faults can be detected by subjecting the fuzing system to special testing during development. Such testing shall simulate the predicted environment to which the fuze shall be exposed during its life. Faults discovered at this stage can often be remedied by relatively straightforward actions.

Examples of faults and events that can result from environmental stress and that can adversely affect safety are listed in the subsections below. The list should not be considered as comprehensive.

New designs and materials may entail new hazard factors.

4.4.1.1 *Mechanical stress*

Examples of the effects of mechanical stress:

- Leakage.
- Cracks in materials.
- Pulverisation of explosives that can subsequently migrate to a position where initiation can occur through shock or vibration.
- Local heating caused by friction between moving parts.
- Mechanical parts of the fuzing systems can be damaged or broken so that initiation occurs during transportation, or prematurely during loading or firing.
- Electric interruptions or short circuits can occur through damage to leads or connections. Sneak paths can also be created by foreign objects. The risk of complex short circuits on printed circuit boards and in connectors, for example, should be particularly considered.
- Cracks in micro-electronic circuits can result in failure effects that are difficult to evaluate.

- Batteries and electrolytic capacitors can be damaged causing leakage of electrolyte that may cause spontaneous ignition of explosives or make them more sensitive.
- During transportation, loading and firing, warheads are subjected to acceleration levels that can disable safety features temporarily or permanently.

4.4.1.2 *Physical and chemical stress*

Examples of the effects of physical and chemical stress:

- Explosives can be heated to such a high temperature that they melt or flow plastically. This can result in explosives get trapped in screw threads or cavities where they may later be affected and inadvertently initiated.
- Explosives can be heated to such a high temperature that they are initiated (cook-off).
- Air can be pumped in and out through leaks whereby water vapour enters the fuzing system. Most explosives are adversely affected by water and become either more sensitive or more inert. Gaseous products can be formed from the reaction that can cause damage to constituent parts, and sometimes may also react with them to form more sensitive compounds (such as copper azide).
- The structural strength, elasticity, and dimensions of the materials from which the fuze is manufactured are affected by temperature so that damage from shocks and vibrations at extremely low temperature, for example, is more likely to occur.
- Extreme variations in pressure can occur that can damage confined parts and thereby affect their function.
- Where there are great differences between the coefficients of linear expansion of explosives and their encasing material, leaks and ruptures can be caused in the casing or cracks may be formed in the explosive.
- Gases or fluids (desirable or undesirable) in the equipment can cause corrosion or other physical changes to constituent materials in the fuzing system.

- Reactions between incompatible materials.
- Condensation and deposits on electrical components and leads can result in sneak-paths and changed electrical characteristics. Corrosion can occur where there is galvanic contact between different metals.

With the introduction of the RoHS Directive (Restrictions of Hazardous Substances), the use of lead in solder and plating materials is forbidden. This means an increased risk of short circuits caused by metal threads (so-called “whiskers”). The directive exempts military products, but since the production of civilian and military electronics can be carried out in the same production facility, the problem shall be addressed.

- Most types of memories (EPROM, Flash, OTP) are based on data being stored capacitively. The life expectancy (so-called “data retention”) of these memories is dependent on temperature and must be addressed since many military systems must have a long service life.
- An inadvertent supply of energy to electric or laser initiators, possibly caused by some environmental factor, can cause initiation.
- An inadvertent supply of electric energy, such as discharge of static electricity, can result in electronic components being damaged in such a way that safety is affected.
- Electrostatic discharge can, in unfavourable cases (in inappropriate designs), directly or indirectly initiate the initiator in the fuzing system.
- An electric potential difference can occur between the ammunition and nearby objects or earth/ground. The risks are greatest when the potential difference is equalized in conjunction with a connection – mechanical or electrical – to the weapon platform or test equipment.
- When connecting and disconnecting electrical equipment, high transient currents can occur inadvertently such as when disconnecting the power source after testing.
- Nuclear radiation can cause malfunctions in electronic components.

4.4.2 Common requirements for fuzing systems

This section presents common requirements for fuzing systems. The section is divided into a number of areas such as design requirements, requirements relating to testing, requirements specific to use, requirements relating to neutralisation, deactivation, recovery and disposal, as well as international legal requirements.

4.4.2.1 Design requirements

1.404.001 T Fuzing systems **shall** be designed to enable safety analysis to be performed.

1.404.002 T The safety level of the fuzing system should be specified numerically as a probability and should be verified by analysis.

Comment: An analysis can be carried out with the help of the FTA (Fault Tree Analysis) and FMECA (Fault Modes, Effects and Criticality Analysis).

1.404.003 T Single failures that can lead to inadvertent initiation of explosives after the interrupter or circuit safety device within the arming distance/time **shall not** occur.

Comment: For some applications, the requirement for redundancy to prevent inadvertent initiation can be resolved so that a system failure results in a fail-safe state.

1.404.004 T Explosive trains containing primary explosives or sensitive explosives (not approved for use after an interrupter) **shall** have at least one mechanical interrupter. Only explosives in accordance with requirement *1.404.005 T* are permitted after that interrupter.

Comment: Refer also to requirements *1.404.142 T*, *1.404.143 T* and *1.404.144 T*.

- 1.404.005 T Explosives after the interrupter or for use in systems without an interrupter **shall** be qualified for such use as specified in FSD 0214 or STANAG 4170 or other relevant international standard.
- 1.404.006 T Fuzing systems should not contain stored energy, such as mechanical, pyrotechnical or electrical, for removing the interrupter towards an armed position in the explosive train.
Comment: Energy for removing an interrupter can best be provided by some unique environmental factor after launch/release.
- 1.404.007 T Stored energy **shall not** be used for both disabling safety features and removing interrupters.
- 1.404.008 T The probability of inadvertent initiation of an explosive after the interrupter or circuit safety device **shall not** be higher than the probability for inadvertent arming.
Comment: A failure must thus not lead to initiation unless all the steps normally required for arming have been completed.
- 1.404.009 T Encapsulation of the explosive train **shall** be designed such that hazard initiation of the explosive train before the interrupter while the interrupter is in unarmed mode does not lead to ejection of fragments or other effects that can cause injury or damage to personnel, property or the environment.
- 1.404.010 T Fuzing systems **shall** be designed and documented in such a manner as to facilitate an effective production control and quality inspection.
- 1.404.011 T All constituent materials **shall** be selected and combined such that no effects detrimental to safety occur during the life of the fuzing system, e.g. as a result of corrosion, mechanical fatigue, mutual interference, or insufficient chemical stability resulting in the formation of copper azide for example.

- 1.404.012 T All explosives **shall** be encapsulated and/or be fixed so that they remain intact when subjected to specified environmental severities.
- 1.404.013 T The initiator in the ignition system **shall not** inadvertently be triggered by a specific external environmental factor such as electrical, mechanical or climatic.
- 1.404.014 T The safe separation distance/time **shall** be established with regard to warhead effect and intended tactical use. Refer also to requirements 1.301.014 T and 1.401.028 T.
Comment: Three different cases can be identified:
 - a. The safe separation distance is so great that the risk to friendly forces is tolerable in the event of a burst occurring when that distance has been reached. No evasive action is assumed.
 - b. The safe separation distance is shorter than in case a. above owing to tactical reasons. Evasive action or taking cover is assumed.
 - c. The safe separation time is sufficiently long to allow for leaving the danger area.
 See definition of safety distance/time in *Appendix 1 Definitions*.
- 1.404.015 T Fuzing systems should be designed so that a failure in the system results in a fail-safe state.
Comment: This requirement can lead to a degradation of any deactivation or self-destruction function.
- 1.404.016 T Fuzing systems should be designed such that incorrect assembly of safety-critical parts is not possible.

1.404.017 T The possibility of final assembly of, or installing, a fuzing system when armed **shall** be prevented. This is achieved when at least one of the following conditions are met.

- a. It **shall** be so designed that during manufacture it is not possible to complete the assembly of an armed fuzing system.
- b. It **shall** be so designed that installing a fuzing system when armed on the ammunition is not possible.
- c. It **shall** be equipped with an indicator which clearly indicates whether the fuzing system is armed or safe.

Comment: Arming may have occurred without being detected as a result of incorrect assembly during manufacture or maintenance, or because the SAI/SAU was not returned to its safe state after final testing.

1.404.018 T If there is a requirement for system testing after manufacture (AUR testing), functions for reliable testing **shall** be built into the fuzing system so that tests can be carried out in a safe manner.

1.404.019 T Fuzing systems **shall** be designed so that maintenance, upgrading, in-service surveillance, disposal and destruction can be carried out safely.

Comment: Necessary instructions etc. for dismantling has to be prepared during the development work.

1.404.020 T The composition and integration of the booster should be such that it does not detonate or deflagrate before the main charge when subjected to heating (e.g. by fire).

1.404.021 T Well-proven components should be used.

1.404.022 T Arming **shall** occur, at the earliest, when the safe separation distance/time is reached.

- 1.404.023 T The arming process should be as simple as possible.
- 1.404.024 T The arming process should be functionally and physically separated from other processes in the system.
- 1.404.025 T Inadvertent arming **shall** be prevented by at least two mutually independent safety features.
Comment: The safety features can be:
 a. mechanical safety features in an interrupter,
 b. mechanically operated electric switches,
 c. relays,
 d. semiconductor switches.
- 1.404.026 T If a system with only two safety features is used, both **shall** be mechanical.

4.4.2.2 Requirements regarding testing

- 1.404.027 T Constituent components and subsystems that are vital to the safety of the fuzing system **shall** undergo separate safety qualification (type testing).
- 1.404.028 T Fuzing systems **shall** undergo safety qualification as specified in FSD 0213, STANAG 4157 or equivalent.
Comment: Safety-critical functions should be monitored during testing and be inspected after testing.
- 1.404.029 T Testing **shall** be performed at a safety level at which arming is not permitted.
Comment: Safety level, in this case, means the stress level which exceeds, by an acceptable margin, the most severe level reached during transport, operation, ramming or the firing/launch process. Testing is intended to verify requirement 1.404.037 T. See also comment to requirement 1.404.039 T.

- 1.404.030 T** The choice of materials in a fuzing system **shall**, if it is considered necessary, be verified by testing that demonstrates with acceptable probability that no effects detrimental to safety occur during the life of the fuzing system. Refer also to requirements 1.202.002 T, 1.202.003 T and 1.202.004 T.
- 1.404.031 T** Testing **shall** be performed to demonstrate whether the design used for encapsulation of the explosives meets the stipulated requirements.
Comment: With this testing, dimensions, compacting pressure and other properties are selected within their respective tolerance range such that the probability for failures is considered to be highest. Testing is to be performed in the environment (within the operating range of the fuzing system) that is considered to be the most unfavourable from a safety aspect.
- 1.404.032 T** Testing **shall** be performed to verify that the fuzing system does not initiate within the safe separation distance/time owing to passage through mask, impact with the sea surface, contact with the seabed, broaching, or collision with objects.
Comment: The concept of ‘inherent safety’ is used for torpedoes.
- 1.404.033 T** Testing **shall** be performed to establish the distance or time from launch or equivalent at which the transmission safety feature arms. If there are other safety features in the explosive train, they **shall** be removed prior to testing.

- 1.404.034 T Testing **shall** be performed to verify that the fuzing system does not initiate in flight or after deployment after the arming process is completed as a result of the environmental stress specified in the requirement specification for the object.
Comment: This requirement applies primarily to ammunition with a split danger area.
- 1.404.035 T Fuzing systems shall be designed to enable the required functional testing to be performed safely.

4.4.2.3 *Requirements for systems with available application-specific environmental factors*

- 1.404.036 T Fuzing systems should be designed so that safety is not dependent upon operating procedures.
- 1.404.037 T Arming **shall** only be possible during use.
Comment: The lower limit for arming must exceed, by a good margin, the maximum stress level experienced during operation, transport and other relevant environmental conditions.

1.404.038 T Arming **shall** only take place if two mutually independent, application-specific, environmental conditions are satisfied, provided that reasonable such conditions are available.

Comment: Examples are stated below of environmental conditions that can be used to activate arming and/or as sources for arming energy:

- a. acceleration,
- b. angular acceleration,
- c. spin,
- d. sensing of launching/mine-laying device (e.g. barrel bore-ride). This is not considered as a good condition, but may be accepted,
- e. dynamic pressure,
- f. drag (via a turbine or parachute for example),
- g. hydrodynamic and hydrostatic pressure,
- h. lanyards,
- i. back pressure.

All conditions to be considered before the most suitable are selected.

1.404.039 T If only one realistic environmental condition is available, or two dependent conditions, there **shall** be at least one manual operation (such as removal of a safety pin) required for arming prior to loading/launching.

Comment: When safety relies entirely on one environmental condition after the manual operation has been performed, a major effort must be made to verify practically and theoretically that this condition cannot occur inadvertently after the manual operation, such as if a shell is dropped during loading.

1.404.040 T A manual operation or safety pin **shall** also block the function controlled by the only available environmental condition.

- 1.404.041 T At least one of the safety features **shall** lock the interrupter during the arming phase until the munition has left the launcher/laying device.
- 1.404.042 T In systems with one or more unique application-specific environmental conditions available, at least one of these **shall** be used. At least one of the safety features **shall** be removed after the launcher/release device has been cleared and the safe separation distance has been reached.

4.4.2.4 Requirements for systems without access to unique application-specific environmental factors

- 1.404.043 T If a fuzing system requires human intervention to start the arming process, there **shall** be a device that provides unambiguous indication of whether the system is in the safe state.
- 1.404.044 T During mechanical deployment of ammunition (such as when laying mines with a minelayer) the arming **shall** take place at the earliest when the mine leaves the laying device.
- 1.404.045 T Fuzing systems **shall** be designed such that the packaged ammunition and fuzing systems remain safe during storage, transport, handling and use. This applies until the point in time when the ammunition is deployed, or when the fuzing system or initiator is installed and arming or activation is performed in accordance with the specified operating instructions.
- 1.404.046 T Incorrect installation of a fuzing system should not be possible.
- 1.404.048 T At least two different and almost simultaneous manual operations **shall** be required for arming to take place.
Comment: These manual operations should be sequential, i.e. carried out in a predefined order.

- 1.404.049 T Electric ignition energy **shall not** occur in the firing circuit until after the specified arming delay or safe separation time has elapsed.
- 1.404.050 T Fuzing systems **shall** be equipped with a device which, after arming, provides sufficient safety time for the operator to leave the danger zone.
- 1.404.051 T The probability of incorrect connection of fuzing systems to explosives, signal and spotting charges owing to a mistake, clumsiness or carelessness **shall** be taken into account.
- 1.404.052 T In cases where safety is based on operational procedures, operating instructions **shall** accompany the packaging or the ammunition.
- 1.404.053 T The fuzing system and components of the fuzing system **shall** be designed such that installation of the initiator can be performed as the final operation in the readiness procedure.
- 1.404.054 T An intentional manual operation, such as removing a safety pin, **shall** be necessary before initiation of the warhead can take place.
Comment: The safety pin is to be designed so that it is not inadvertently removed during normal handling of the ammunition.
- 1.404.055 T The initiation device for demolition charges **shall** be designed so that the connected system can be disassembled safely after connection and be reused if so stipulated.
- 1.404.056 T When the application permits, fuzing systems for demolition charges should incorporate an interrupter that is remotely controlled from the initiation device.

1.404.057 T Time fuzes should incorporate an interrupter that arms after the fuze is set and after personnel have taken cover. The initiation device is armed when the interrupter is removed from the explosive train.

Comment: Where application-specific environmental conditions are available (such as hydrostatic pressure for underwater time fuzes) they have to be used. For other time fuzes manual time-delayed arming, for example, can be used.

1.404.058 T Ignition cables **shall** be long enough to enable connection of the initiation device without it being necessary for personnel to be inside the danger area of the warhead.

1.404.059 T If requirement 1.404.057 T cannot be met, the initiation device **shall** incorporate a time function that provides a delay in arming of sufficient duration to enable the operator to leave the danger area or take cover.

1.404.060 T Initiation devices should be designed so that the risk of ignition failure is minimised.

Comment: Consequently, it should be equipped with a continuity tester and an indicator to show that it can deliver sufficient ignition energy.

1.404.061 T To minimise the risk of inadvertent initiation, initiation devices **shall** be designed so that at least two manual operations are required to enable firing.

1.404.062 T There **shall** be at least one mechanical/galvanic interrupter in the firing circuits of initiation devices.

Comment: The output on the initiation device can also be short-circuited up to the moment of firing (e.g. by one or more electromechanical switches).

4.4.2.5 *Neutralisation, deactivation, recovery and disposal*

- 1.404.063 T Firing capacitors **shall** be equipped with duplicate discharge (bleeder) circuits. At least one of these circuits **shall** be physically located as close to the firing capacitor as possible.
- 1.404.064 T The leakage resistance of firing capacitors, or for grounding in twin conductor systems, **shall** be as low as the system permits.
- 1.404.065 T Fuzing systems incorporating a deactivating function **shall** contain a device that indicates in an unambiguous way whether the system is safe.
- 1.404.066 T Deactivation **shall** provide at least the same level of safety as when the system was initially in safe mode.
- 1.404.067 T Deactivation should not require special tools.
- 1.404.068 T Deactivation should remove all initiation energy.
- 1.404.069 T The fuzing system should be designed such that deactivation/neutralisation is not prevented by a malfunction in any part of the fuzing system that is not used for deactivation/neutralisation.
- 1.404.070 T If clearance for disposal or recycling is intended the fuzing system **shall** be designed for subsequent safe handling.

4.4.2.6 Requirements of International Law

1.404.071 T Land mines **shall** have a self-destruction, neutralisation or deactivation function that renders the mine safe after a certain time. This function can be automatic or remotely controlled.

1.404.072 T Drifting mines **shall** have fuzing systems that ensures that the mine is rendered safe one hour after deployment at the latest.

1.404.073 T Moored mines **shall** be neutralised as soon as the mine is no longer moored.

1.404.074 T Torpedoes **shall** be neutralised if they do not hit the target.

1.404.075 T For ammunition with submunitions, these **shall** meet the requirements of the “Convention on Cluster Munitions”.

Comment: The definition of Cluster Munitions includes all ammunition with explosive submunitions under 20 kilograms weight. Ammunition is explicitly excluded from the definition of cluster munitions which, “in order to avoid indiscriminate effect over a surface”, has the following five characteristics:

- the ammunition consists of less than ten explosive submunitions,
- each explosive submunition weighs more than four kilograms,
- each explosive submunition is designed to detect and strike a single target,
- each explosive submunition has an electronic self-destruct mechanism,
- each explosive submunition is equipped with electronic deactivation.

- 1.404.076 T Submunitions **shall** be equipped with auto-destruction.
Comment: See requirements in *Clause 4* of the Convention's definition in requirement 1.404.075 T above.
- 1.404.077 T Submunitions **shall** be equipped with a neutralisation/sterilisation function which renders the submunition safe after a certain period of time.

4.4.3 Mechanical subsystems

- 1.404.078 T The interrupter **shall** prevent the booster charge in the fuzing system from initiating in the event of an inadvertent initiation of the explosive train before the interrupter.
- 1.404.079 T The interrupter **shall**, in the safe position, be locked by at least two independent safety features.
- 1.404.080 T The interrupter in an explosive train should, before arming, remove the sensitive explosive (out-of-line) from the explosive train.
- 1.404.081 T Each of the safety features **shall** individually retain the interrupter in the safe position.
- 1.404.082 T Safety features in an interrupter should lock directly into the interrupter, not via any linkage or similar device.
- 1.404.083 T Testing **shall** be performed to establish that an interrupter remains locked in the safe position with sufficient margin when subjected to the most severe load (Compare the environmental specification) when only one safety feature is installed. The safety features are to be tested separately.

1.404.084 T Testing **shall** be performed to establish that explosives located after the interrupter are not initiated by the detonator while the safety device is in the safe state.

Comment: The following is to be taken into consideration:

- the critical thickness of a mechanical barrier,
- the critical charge quantity and compacting pressure of a detonator located before the interrupter,
- the critical gap and dimensions etc. of gas passages through or around the interrupter. The term ‘critical’ denotes the value when transmission in some form takes place. Testing can be supplemented by calculations.

1.404.085 T Testing **shall** be performed to determine at which point transmission is achieved when the interrupter is gradually moved from safe to armed position. Dimensions **shall** be chosen within each tolerance range so as to facilitate transmission. Between safe position and the limit position for transmission, any ejection of fragments, deformation or fragmentation **shall** not entail a risk of injury.

Comment: For interrupters with an instantaneous arming motion, testing can be performed in fewer positions (at least one) between safe and armed positions.

4.4.4 Electrical subsystems

Consideration shall be given to the following factors inter alia when designing fuzing systems to achieve protection against inadvertent function:

- Selection of components
 - Arming relays to be selected such that an electric current maintains the relay in armed state, and any break in voltage supply results in the relay returning to safe state.
 - Mechanical initiators for thermal batteries are to be selected such that they do not activate the batteries in the event of a failure. When selecting components all the environmental factors to which the system can be subjected are to be taken into account.
- Static electricity
 - Any uncontrolled discharge of static electricity can cause inadvertent initiation of the fuzing system. The design must ensure that the electrostatic discharge can occur via a resistor or in some other way.
- Electromagnetic energy
 - The design must provide the best possible protection from electromagnetic influences including lightning, EMP (electromagnetic pulse) and HPM (high power microwaves). Protection can be achieved in the following ways:
 - Metallic shielding of sensitive components. Storage containers can give considerable protection against electromagnetic energy.
 - HF shielding of openings where there are controls and connectors.
 - Filtering of HF signals, especially at cable feed-throughs.
 - Circuit breakers (relays) and connectors that are insensitive to HF energy shall be located as close as possible to the protected components to preclude use of long cables that assimilate energy.
 - Shielded connections shall be of low resistance and shall be fully shielded at all connection points.

- Earth/ground currents
The design shall ensure that earth/ground loops are avoided and that earth/ground currents are kept at a safe level during operation, loading and testing.
- Connectors and cables
Connectors and cables are to be designed and located to achieve maximum protection against short-circuiting resulting from ingress of moisture and foreign matter, e.g. connections can have insulating combs between connection points. Connectors are to be designed such that they cannot be assembled incorrectly nor be incorrectly connected.

1.404.086 T	Fuzing systems should not be capable of accumulating sufficient energy to initiate the warhead within the safe separation distance/time.
1.404.087 T	Connector pins in external connectors connected to an EED should be semi-enclosed.
1.404.088 T	The casing of an external connector should make contact and provide electromagnetic shielding before the pins engage.
1.404.089 T	The shielding of ignition cables should be connected to the casing of the connector around the complete circumference of the cable. <i>Comment:</i> This is particularly important with the casing of an EED to obtain good high frequency protection. The connection pins in a connector should not be used to connect shields.
1.404.090 T	The switch that finally connects an EED to the electric supply should be located as close to the initiator as possible.
1.404.091 T	The lead/leads between the switch and the EED shall be shielded from external electromagnetic fields and be protected against static electricity.
1.404.092 T	The capacitance across the switch should be kept sufficiently low to prevent initiation by electrostatic discharge.

- 1.404.093 T Twin conductors should be twisted.
- 1.404.094 T If one pole of an EED is grounded, the ground path should be as short as possible to the shield that surrounds it.
- 1.404.095 T Ignition cables **shall not** be located in the same shield as other conductors.
- 1.404.096 T An EED **shall** be tested according to FSD 0112, STANAG 4560 or equivalent.
- 1.404.097 T Fuzing systems containing EEDs **shall** be system tested in accordance with FSD 0212, STANAG 4157 or equivalent.
- 1.404.098 T EED used in fuzing systems with an in-line explosive train intended for warheads **shall** have an ignition voltage of at least 500 V.
- 1.404.099 T When two electric signals are used for arming at least one of them **shall** be dependent on a continuous current supply.
- 1.404.100 T If the current supply ceases before arming is completed the fuzing system **shall** be neutralised or deactivated.
- 1.404.101 T In a system where the arming process is controlled by electrical safety features, at least two of them **shall** be in the form of an interruption from the current supply.
- 1.404.102 T Fuzing systems in which arming is performed by connecting the circuit to earth/ground (single conductor system) should be avoided.
- 1.404.103 T Arming **shall not** occur as a result of plausible short circuits such as short circuits between adjacent leads in harnesses, in connectors, on PCBs and in integrated circuits.

- 1.404.104 T Arming **shall not** occur as a result of a plausible interruptions caused by, for example, soldering defects, oxidised connector surfaces, or cracks in PCBs or substrates.
- 1.404.105 T For systems with only semiconductors as safety features, at least three independent ‘closings’ **shall** be required at system block level for arming.
Comment: The closings are best actuated by different signal levels.
- 1.404.106 T A system containing only semiconductors **shall not** be able to arm as a result of static failures in the safety features (failure mode either closed or open), which can mean that at least one of the safety features requires a dynamic signal.
Comment: The dynamic signal must be of such a nature that it cannot reasonably occur inadvertently.
- 1.404.107 T The safety analysis of a fuzing system **shall** be performed by at least one independent party. For system solutions with semiconductors only, the analysis should be performed by at least two independent parties.
Comment: A special system safety function within the company that designed the system can be considered to be an independent party.

The following requirements apply to electronic circuit safety devices:

1.404.108 T A fuzing system with an in-line explosive train intended for warheads **shall** be initiated only by a signal that is unique and cannot be emulated by any undesired internal or external signal.

Comment: Usually only high power systems (such as EFI) are used in systems containing only electronic fuzes.

1.404.109 T Charging of a firing capacitor or equivalent should only be started after the safe separation distance/time has been reached.

1.404.110 T The voltage of a firing capacitor or equivalent **shall** be below the lower initiation voltage (maximum-no-fire) until the arming distance/time is reached.

Comment: This is analogous to the conventional case with one interrupter that moves slowly and enables transmission in the explosive train at some point before final position. Complete arming is achieved when the voltage of the firing capacitor reaches the minimum-all-fire level of the electric igniter.

4.4.5 Electronic and software controlled subsystems

Technological developments have led to the replacement of mechanical and electromechanical designs with electronic circuits. This trend is driven by the major advantages afforded by electronics such as high performance, low weight, great flexibility and low price. Modern electronics is characterised by programmability and by shrinking geometries.

The use of electronics in fuzing systems, however, is far from trouble-free. Often any failure in the electronics will affect not only function but also safety. Consequently, there are good reasons for exercising great caution as analysis and verification as a rule are complex activities.

In fuzing systems with an out-of-line explosive train, transmission in the explosive train is certainly prevented, but if the interrupting function as such is controlled by electronics only, the system should be considered as an electronic fuzing system from a safety point of view.

The increasing use of complex electronic circuits and software in safety-critical applications creates a need for rules and guidelines concerning the development of such systems. Those used for the design of conventional electronics are not directly applicable.

Conventional safety analysis deals with the consequences of component failures or the fact that they are missing. The behaviour of the system in various failure modes can hence be predicted. Software does not normally change in such a way that failures occur after the system has been developed. However, there is a risk that the system still does not, for all intents and purposes, behave as intended; bugs in the software may have been introduced during the development or modification of the system. Unfortunately, it is not usually possible to prove afterwards that an existing software program is free from bugs in all respects. Safety requirements must therefore be satisfied via a systematic work process throughout the design, development, testing, configuration management, and documentation.

Safety shall be built into the system's architecture from the outset. By starting with possible failure modes in the system at block diagram level, a fault tree can be constructed and practicable and verifiable requirements can thereafter be formulated for the individual basic events in the fault tree (component faults). Safety-critical functions shall be designed so that they can be easily analysed, which also results in a reduced risk of introducing failures when future modifications are made of the function.

In safety-critical systems, software may constitute a useful tool for the monitoring and control of safety functions. The software can then detect faults in these safety functions, and if a fault is detected, appropriate measures can be taken to reduce the probability of a hazardous event

There are different types of logical circuits in electronic fuzing systems which are used to implement safety features and arming and firing functions.

The most common types of logic circuits are:

- Programmable logic:
 - Complex Programmable Logic Devices (CPLD),
 - Field Programmable Gate Arrays (FPGA),
 - Programmable Logic Devices (PLD),
- Application Specific Integrated Circuits (ASIC),
- Microcontrollers/Microprocessors,
- Discrete logic.

Some of these circuits are programmable, which puts demands on the software's design and on the methodology used in its design.

Software for safety-critical systems has to be stored in non-volatile memories (firmware), such as ROM, EPROM and flash memory. The stored program is usually executed in a microprocessor. Logic functions can also be implemented directly in programmable logic such as CPLD, FPGA, PLD, or in an ASIC.

ISP (In System Programming) of flash memories should be blocked so that it is not possible to easily reprogram the memory.

1.404.111 T All safety-critical functions in electronic circuits **shall** be implemented in firmware or hardware.

1.404.112 T It **shall not** be possible to easily change the software after it has been installed in the circuit.

4.4.5.1 Radioactive impact

The development of electronic components results in that smaller and smaller geometries are being used, trace widths and components are reducing in size. With lower and lower capacitance for every stored bit there is an increased risk of disturbances occurring e.g. Single Event Upsets (SEUs) caused by radiation.

The radioactive particles that can cause the greatest damage in a microcircuit are neutrons and alpha particles. The circuit types that are most susceptible to radiation are microprocessors, and SRAM (Static Random Access Memory) based circuits. The errors that occur (SEU) can vary from temporary memory faults that are corrected through a restart of the system to faults that cause the system to fail completely.

By selecting the appropriate electronic components as well as introducing redundancy and error correction, the risks of radiation induced faults can be reduced. The risks of alpha radiation can be reduced through the appropriate choice of solder and integrated circuit packaging material.

1.404.113 T Data in firmware **shall not** be able to be changed by any environmental impact which the system can otherwise withstand.
Environmental impact includes the effects of radiation.

4.4.5.2 Redundancy

The risk of manufacturing faults or environmental dependent faults (Common Cause) is reduced if different types of circuits are used. The risk can be further reduced if different brands of circuits are selected.

1.404.114 T If all safety features are implemented with logic circuits, at least two of these **shall** be implemented with different types of logic circuits.

4.4.5.3 *Unused features and environmental durability*

The manufacturer's specifications and recommendations for the chosen logic circuits shall be followed. The circuit manufacturers' specifications may sometimes be changed when more knowledge of the circuit or the manufacturing process has been acquired. Current data sheets shall therefore always be used. An example of a parameter that can be chosen by the designer is the system's clock frequency. The maximum permitted frequency is a function of the temperature and of the supply voltage and shall not be exceeded under any operating conditions.

All unused inputs and outputs as well as other unused features shall be terminated in the manner prescribed by the manufacturer. The environmental durability specified for the components shall always be complied with by a good margin.

1.404.115 T The component manufacturer's specifications and recommendations **shall** be followed.

Comment: The requirement may for example be verified by minutes from completed design reviews.

4.4.5.4 *Risk of short circuits*

The probability of short circuits in the system directly or indirectly leading to safety features being removed can be reduced by physically separating the various subsystems. The causes of short circuits may be that moisture is formed, or has penetrated the system, or that metal wires (whiskers) are formed. The risk of whiskers forming increases if lead-free solder is used. In wires that are pinched there is a risk that the insulation is softened and after a long time causes a short circuit.

1.404.116 T The design **shall** be such that the likelihood of short circuits occurring at circuit board level is minimised.

Comment: The use of lead-based solder is in conflict with the RoHS Directive.

4.4.5.5 Competence of the supplier

To ensure that knowledge of the system is available in order to carry out additional analyses and changes, even if a designer leaves the assignment, at least one more person shall possess detailed knowledge of the system. This also provides a certain degree of control that the system is designed in accordance with the specification.

1.404.117 T At least two people at the manufacturer **shall** in detail be familiar with the functionality of the hardware and software, as well as what tests that have been carried out on the system.

4.4.5.6 Service life of stored information

The service life of a memory chip, i.e. how long it can retain its information, is determined by several parameters. The most important factor is the process in which the memory has been manufactured (Flash, EPROM, ROM, EEPROM etc.), the storage and operating temperatures and the number of write operations that are made. The service life of a memory can be expressed as the number of years the chip retains the memory content intact at a specified temperature (Data Retention), as well as the number of write and erase cycles that can be carried out on each memory cell without any data being lost (Endurance).

If it is necessary to extend the life of a memory by reprogramming the chip (Refresh) this can be done by using the original file or data being read from the memory, the data is then written onto the chip. After this operation has been performed, the ISP should once again be blocked.

1.404.118 T The content of the memory circuits **shall** have a service life that with a margin exceeds the system's projected service life if reprogramming (Refresh) is not possible.

Comment: Service life relates to both how long a memory cell can retain its information in the current operational profile (measured in years), and the number of write operations that can be performed on each individual memory cell.

4.4.5.7 Power supply

The power supply in safety-critical subsystems shall be robust, designed so that load variations or disturbances do not cause faults that could result in inadvertent arming or initiation. To avoid faults in other parts of the system affecting the fuzing system, the power supply for the logic systems which implements safety features, should be separated as far as possible from the rest of the system (e.g. the communications system). The power supply for the logic systems which implements the safety features shall be connected as late as possible in the arming process.

1.404.119 T The power supply for the logic system that implements safety features **shall** be designed so that a fault in the power supply does not result in one or more safety features being removed.

4.4.5.8 System restart, RESET

In order for the electronic components to function as intended, the supply voltage shall never fall below the minimum voltage specified by the manufacturer for the operating environment in question. If the voltage drops below the minimum specified level, the microprocessor may not execute the instructions correctly and the contents in RAM, registers and the input and output ports may become corrupt. Similarly, the functioning of a FPGA (Field Programmable Gate Array) may become unpredictable.

To ensure that the system is working properly, a restore function is required, RESET, which keeps the circuit in a defined state when an under-voltage condition occurs, and then restarts the circuit correctly when the voltage reaches the specified level. Even very short voltage interruptions or transients can stop a programmable circuit from working. Most microprocessors and gate arrays (e.g., FPGA, CPLD) contain a built-in reset circuit to ensure that it starts correctly. These internal circuits are rarely designed to handle complex voltage fluctuations, transients or a slow varying supply voltage. Internal reset functions are activated

when programming the chip (fuse bits) or by code being executed at start-up which makes it difficult for an external reviewer to determine whether the feature is enabled.

Any logic circuit which implements a safety feature shall have its own independent reset function so that a single fault or a Common Cause fault do not lead to an unsafe condition. The various reset functions should be implemented by using different techniques.

Reset function shall be robust and able to handle all the various types of disturbances that occur on the supply voltage.

Even discrete logic, such as latches and registers, shall be started in a defined state.

The system shall always start in a safe state. Even when the system shuts down (intentionally or because the supply voltage disappears) it shall do so in a controlled manner.

1.404.120 T The system shall assume a safe state at disturbances in the power supply and at start and stop.

4.4.5.9 *Self-test*

Immediately after start, a self-test shall be conducted that verifies that all safety-critical components have been initialised to a safe state. In microprocessors, a self-test shall be carried out to ensure that critical parts of the processor do not contain faults. In some situations, a comprehensive test at start-up may take too long to carry out, then the parts to be tested should be prioritized so that at least the most critical parts are tested.

RAM is tested to verify that no memory cells are stuck at 1 or 0, it is also important to test that writing and reading a cell does not affect adjacent memory cells. RAM is also tested to make sure that the address decoder works by checking that data is written to and read from the correct address.

ROM is tested to verify that the program memory is unchanged. This is usually done by calculating a checksum or a CRC on the entire content of the memory. The result has then to be compared to a stored reference value.

EEPROM is tested in the same way as ROM, except that the content may have changed while the system is in operation. The calculated reference value must in this case be updated each time the content of the memory is changed.

The clock frequency should be tested at start-up if the frequency is safety-critical, for example if it is used for the calculation of an arming delay. A serial communications link or an independent oscillator can be used for the frequency test. A Watch Dog Timer (WDT) should if possible be tested directly after start.

All ports and registers shall be tested so that they have been initialised properly.

A/D converters are tested by connecting a reference voltage to the input. For A/D converters embedded in a microprocessor, the internal band gap voltage reference may be used.

1.404.121 T After start, a self-test **shall** be carried out which verifies the function and condition of as many safety-critical components as possible with regard to time and performance requirements.

4.4.5.10 Program flow control, Watch Dog Timer (WDT)

In order to ensure that the microprocessor executes the program instructions in the sequence that is expected, the system shall include a monitoring function, commonly called a Watch Dog Timer or referred to simply as Watchdog.

The Watchdog, in its simplest form, consists of an independent external counter that automatically counts up until it is reset by a command from the microprocessor. If the counter is not reset within a certain time interval it generates a restart (Reset) of the microprocessor. The WDT should only be reset if the reset signal is generated within a defined time window. Advanced watchdogs can be implemented in a gate array or in a separate microprocessor, which in that case shall have a separate system clock.

The Watchdog shall not be reset from inside an interrupt routine because this can be executed even if the main program is stuck in an uncontrollable loop. However, it may be appropriate that the Watchdog is reset through a combination of instructions which can in part be placed in an interrupt routine.

Even discrete logic circuits such as latches and registers shall be forced to a defined state following a reset by the WDT.

Microprocessors usually have a built-in WDT. A problem with these built-in counters may be that they are activated by executing instructions in code and that it cannot be verified that the WDT really has been started. It is also uncertain how independent these built-in WDTs are from other functions in the circuit.

1.404.122 T Programmable circuits shall have a monitoring function that puts the system in a safe state if the program execution is disrupted.

4.4.5.11 Software

The requirements of this section are applicable to electronic fuzing systems which are wholly or partly controlled by software. Software here is referring to coded instructions that are stored in a memory and executed sequentially in a microprocessor. Even the software that defines the configuration of programmable logic circuits is subject to the following requirements where applicable.

Even if the software in a microprocessor or equivalent represents only one of several safety features to prevent arming and firing, stringent requirements shall be applied to the software's design and development. The reference lists in *Appendix 3* and *4* include examples of standards, textbooks and design principles for how software in safety-critical systems shall be designed. If no standard has been specified in the requirement specifications for development methodology and process, the manufacturer shall choose to apply H ProgSäk 2018, Chapter 2 or a suitable standard for the design of the software. When verifying the fulfilment of requirements, the choice of development standard shall be presented and justified.

1.404.123 A Software development **shall** be carried out systematically and in accordance with a recognised standard or manual. The choice of developing standard **shall** be presented and justified.

1.404.124 A For safety-critical systems, software and development methodology **shall** be reviewed by an independent third party.

Comment: An independent auditor may be a person in the same company that developed the software, but who was not involved in the development.

The function of microprocessors and programmable logic circuits shall be specified; all inputs and outputs shall be defined and described. The function of inputs which can be set to outputs by the software shall be analysed with respect to the risk of a port inadvertently sourcing current; an input may, due to a fault, be changed to an output.

All modules shall be described in the source code, and safety-critical functions shall be highlighted and described in order to prevent them from being removed or changed accidentally.

An analysis shall be carried out to ensure that the processor's capacity is not exceeded; there shall be a margin which will allow for changes during development.

The software shall be developed with systematic and documented methods. The manufacturer shall justify the choice of programming language and the choice of development tools. Only tools recognised and accepted by the circuit manufacturer shall be used. If a high-level language is used, only well-known and well-proven compilers shall be used. The compiler shall be able to generate an assembly listing making it possible to analyse the code generated by the compiler.

In order to achieve adequate performance, it may be necessary to use assembly language. This may also be necessary if the memory space is limited, or if a direct control of external hardware is

required. If all or part of the programming is done in assembly language, it shall be possible to easily analyse the program flow, preferably with the help of flow charts.

During development, all changes shall be made in the source code. Changes directly to the object code, so-called patching, must not occur. (Such changes may often remain undocumented.)

The software shall be subdivided in modules, so-called subroutines or functions. The consequences of a fault in each module shall be analysed. Each module shall also be defined and described with regard to its function, input and output parameters, as well as variables and registers used and modified.

An advantage of microprocessors is that it is easy to make changes in the code. After the software has been developed and validated through extensive testing, the same validation process must be carried out after a change has been made, so-called regression tests.

In order to easily be able to determine which version the program has, a revision identification shall be stored as a constant in ROM or as a label on the circuit board.

1.404.125 T Configuration control **shall** be implemented for all developed software and the revision identification can preferably be included as a constant in the program memory or as a label on the circuit board.

1.404.126 T Software for safety-critical systems **shall** be designed and documented so that it is possible to analyse its function.

1.404.127 T The developed software **shall** be tested extensively. The choice of test method shall be documented and justified.

1.404.128 T Software in safety-critical systems **shall** be as straightforward as possible.

Interrupts can be an effective way to control the program flow, but interrupt handling must be strictly controlled. Recursive interrupts may result in the program flow being non-deterministic or that the stack overflows. A hardware failure can lead to a continuous stream of interrupt requests, which in turn can lead to the prevention of a normal execution.

1.404.129 T Interrupts **shall not** be able to cause stack overflow, disruptions to the program execution, inadvertent changes to variables, or a non-deterministic behaviour.

1.404.130 T The program execution **shall** be deterministic.
Comment: An example of a deterministic system is a state machine where each new state is predictable and only depends on the current state and input signals.

A temporary disturbance can result in a call of an undefined interrupt routine.

1.404.131 T All interrupt vectors **shall** be defined and the vectors that are not used **shall** lead to a safe state, such as RESET.

Even ports that are initialised with a specific value at start-up are to be periodically updated if possible to ensure that a disruption does not change the port data during operation. Other registers that are normally initialised automatically at start-up are also to be checked regularly during operation, such as the data direction registers for the ports.

1.404.132 T Registers that are important for the function **shall** be verified during operation.

1.404.133 T If an error is detected during a self-test or during operation, a planned action **shall** be available and performed.

Incoming data may be digital signals, or analogue signals which are A/D converted externally or internally in the microprocessor. Each incoming value which is of importance for safety shall be evaluated to ensure that it comes at a reasonable point in time and that the value is reasonable.

1.404.134 T All input signals to the processor **shall** be assessed for reasonability.

A common mistake in software development is that routines that are used for developing and testing are left in the code but are made inaccessible and never called. There may also be routines that are used in other variants of the system. The same programmed circuit can then be used in different systems but with different routines depending on in which system the circuit is installed. This so-called dead or sleeping code must not be used in a safety-critical system. The dead code may contain functions that have not been analysed and tested and which may therefore create a risk in a safety-critical system. A disturbance may cause the program pointer to incorrectly force the processor to execute this dead or sleeping code.

1.404.135 T Code that will never be used, so-called dead or dormant code, **shall not** be present.

If a fault causes the processor to try to execute code in an unused area of the memory, it may lead to uncontrolled program execution. Unused program memory space shall therefore be filled with data which, if executed as instructions, shall result in a restart or a safe state. It is usually not sufficient to rely on a Watchdog resetting the system if it gets stuck in an infinite loop. A poorly designed Watchdog may be prevented from restoring the system if the Watchdog reset is generated in an interrupt routine.

1.404.136 T Unused memory space **shall** be programmed with code so a jump to such space results in a safe state, e.g. a restart.

A software error which is difficult to locate arises if the index in an indexed memory operation is calculated incorrectly. If the processor attempts to address memory outside the physical memory area, phenomena may occur which are difficult to explain.

1.404.137 T All indexed memory operations **shall** be checked so that the index assumes permitted values.

Values that define a safety-critical state should be coded so that at least four bits are unique. Example: If ARM is indicated with a Hex “a”, SAFE shall be indicated with Hex “5”.

1.404.138 T One, two or three bit errors **shall not** be able to lead to dangerous malfunction in the software, for example arming of an ignition system.

1.404.139 T Arming **shall** require that a sequence is executed where the previous state is a necessary condition for the subsequent arming condition to be executed.

4.4.6 Subsystems with wave-borne signals

If an arming system uses a signal transmitted via a carrier the system will be open to all signals – intentional as well as unintentional – that reach its input. It must thus be ensured that only the correct signal can result in arming, and that the probability of an unauthorized signal reaching the system is made sufficiently low. This can be achieved, for example, by:

- using a sufficient number of combinations and a sufficiently narrow bandwidth,
- limiting the transmitted signal strength and adding directivity,
- selecting codes so that only a limited number of objects can be armed by the same code,
- changing the signal before the next operating occasion,
- varying the signal when repeating commands to the same object,
- being able to vary codes or data for signal configuration when deploying the object,

- ensuring the code cannot be deciphered despite wide knowledge of the safety system,
- incorporating a time-dependent parameter in the signal in cases where arming will take place at a later occasion after deployment.

1.404.140 T In systems with wave-borne signals the probability of unauthorized arming/influence **shall** be sufficiently low with regard to the field of application.

1.404.141 T If a signal outside the ammunition is used for arming, the fuzing system **shall** verify the signal before arming takes place.

4.4.7 Laser fuzing systems

A laser fuzing system in its most elementary form consists of a laser, optical fibre, and a detonator. It is also possible to transmit laser energy directly to the detonator without an optical fibre.

For a system without an interrupter in the explosive train, the laser must be prevented from releasing initiation energy to the detonator before the safe separation distance/time has been reached/has elapsed.

This can be prevented by:

- separating the laser from the detonator by a barrier introduced into the beam, or by blocking the laser cavity. The requirements for the barrier/blocking then become the same as for an interrupter,
- safety features to prevent the electronics from activating the laser.

For laser systems with an interrupter in the explosive train, the standard requirements for an interrupter apply.

4.4.8 Fuzing systems for other types of ammunition

Fuzing systems with an in-line explosive train have been traditionally accepted for use in demolition devices, signal and spotting charges, hand grenades, and mine disposal ammunition such as mine clearing charges, explosive cutters and acoustic explosive sweeps, even though sensitivity requirements are not met for such fuzing systems. The initiator usually consists of a primer or detonator that is initiated by electrical or mechanical energy. Safety is mainly based on the observance of regulations governing use. For new procurement of such ammunition, however, the requirements in this section should also be applied.

4.4.8.1 *Explosives*

Demolition devices (such as plastic explosives, demolition sticks, Bangalore torpedoes and linear charges) are initiated by initiation devices and fuzing systems consisting of, for example, a safety fuze, PETN fuze, non-electric fuze, or solely a detonator with electrical or mechanical initiation. It is vital that fault-free materiel and only the prescribed initiation device are used to prevent hazard initiation.

4.4.8.2 *Signal and spotting charges*

Signal and spotting charges are ignited by devices such as a primer in combination with a safety fuze, or percussion primer with wire actuation.

Signal rounds for underwater use can have explosives which, in the event of hazard initiation in air, can cause great damage. For this reason they should have a safety system to which the requirements in this section are applied to the greatest possible extent.

4.4.8.3 Hand grenades

Hand grenades are of different types such as smoke or high-explosive grenades. The latter are the most dangerous, having on many occasions caused injury during training.

In the most common hand grenade types, there is an ignition system containing a detonator, which is initiated mechanically (hand grenade fuze). The hand grenade fuze is stored separately and is installed only when the grenade is to be used. In this case, the separated detonator acts as a “transport safety device”. If the detonator is stored mounted, it leads to higher demands on the ignition system to maintain safety during the transport and storage phase.

For newly procured hand grenades, however, the requirements in this section should be applied to the greatest possible extent. Alternatively, STANAG 4497 may be applied.

4.4.8.4 Counter mining charges and explosive cutters

Counter mining charges and explosive cutters are initiated by a fuzing system consisting of a mechanically initiated detonator. In addition to a transport safety device they incorporate a safety device that requires them to be submerged in water (water pressure).

4.4.8.5 Auto destruction

If the fuzing system contains an integrated auto destruction or anti-tamper device etc., this function shall have the same degree of safety against hazard initiation as the rest of the system.

4.4.8.6 Submunitions

Fuzing systems in submunitions are subject to the same basic requirements as other fuzing systems. Submunitions can have special functions and characteristics for which it is important to observe the following:

- That the safety features are removed in the proper sequence. This can be crucial, for example, for a submunition in an artillery shell in which the first safety feature is removed when the shell is fired, the second safety feature is removed when the submunition is ejected.
- That the safety features are removed as late as possible with regard to available environmental conditions. For an air-carried pod system it could, for example, be unsuitable to remove the first safety feature when the pod is released from the aircraft since the aircraft is often close to the pod for a long time after separation. Instead, the separation of submunitions from the pod and the drag force from the parachute etc. should be used as conditions for safety features. Separation from the aircraft may, however, be used as an 'extra' safety condition and as a prerequisite for removing the other safety features.

For submunitions containing high explosives, it is often necessary to include auto destruct function because the risk of obtaining unexploded ordnance is relatively high. In addition, unexploded submunitions are usually difficult to detect.

4.4.8.7 Multi-purpose ammunition

Multi-purpose ammunition is a special type of tube-launched ammunition that exists mainly in the 12.7 – 40 mm calibre range. A characteristic feature of this type of ammunition is that it lacks a conventional fuzing system, and that the explosive reaction is rather deflagration than detonation. The explosives in the warhead are initiated solely by the transfer of energy that occurs when the shell hits the target.

The safety measures intended to prevent inadvertent initiation can therefore only be regulated to a certain extent by applying the requirements in this section. Instead, safety must be verified by testing tailored to the operational environment of the object.

A safety margin can be achieved by increasing the level of severity during testing in relation to the operational environment. In addition, FMEA testing ought to be performed with regard to the possible malfunctions that can cause safety hazards.

4.4.8.8 Tandem systems

The requirements stated in this section shall apply to the initiation of each warhead in systems containing several warheads (i.e. tandem systems).

The warheads can have separate or common fuzing systems.

4.4.8.9 Propulsion devices

A propulsion device is usually made up of a propellant or a pyrotechnic composition. Existing fuzing systems for propulsion devices often lack a transmission safety device despite the fact that the propulsion device itself in the event of an inadvertent initiation can cause great damage, and even in some cases can indirectly activate the fuzing system for the warhead.

For newly designed fuzing systems for propulsion devices, it is desirable that the requirements stated in this section be applied. In order to assess all of the safety measures designed to prevent hazard initiation, it is often necessary to consider and analyse the design of the entire weapon system and all of its safety functions.

For electric or laser initiation of propulsion devices for rockets and missiles, STANAG 4368 applies.

1.404.142 T There **shall** be a transmission safety device in the explosive train of propulsion devices if inadvertent initiation of the propelling charge leads to activation of the fuzing system in the warhead.

Comment: Guidelines as to when the transmission safety device must exist in other cases, for example when an inadvertent initiation can cause great harm, can be found in STANAG 4368.

1.404.143 T The electric igniter in the propulsion device **shall** be sufficiently insensitive so as not to be initiated leading to inadvertent initiation by any radiated interference or static electricity.

Comment: The aim must be that an electric igniter can be subjected to a current of 1 A and a power of 1 W for a minimum duration of five minutes. An analysis of the safety of the complete safety and arming system must, however, as a rule be carried out.

1.404.144 T The explosive in a booster charge after an interrupter, or in an initiator in a system without an interrupter, should not be more sensitive than the explosives in the propelling charge.

1.404.145 T It should be possible to install the fuzing system into a propulsion device as late as possible before operation.

1.404.146 T It should be possible to check easily whether the fuzing system is installed in a propulsion device.

1.404.147 T The fuzing system should be easily accessible for replacement.

1.404.148 T The fuzing system **shall** be designed so that normal firing takes place within the specified time-frame (i.e. abnormal delay is prevented).

4.5 PACKAGING FOR AMMUNITION

To ensure that the characteristics of the ammunition are maintained during transport and storage it is essential that ammunition be protected by appropriately designed packaging whose task is:

- to protect its contents against the adverse effects of the relevant environmental factors,
- to protect the surrounding environment.

For packaged ammunition, two separate environmental concepts are used, the external environment, in which environmental factors affect the ammunition, and the internal environment (also called the micro environment) which relates to the environment inside the packaging.

It is essential that packages are clearly marked to enable rapid and safe identification (even under stressful conditions) to prevent dangerous mix-ups during handling.

It is important to consider the question of packaging at the earliest possible stage during the development of ammunition to enable the specified safety level to be achieved in the most appropriate way. Comprehensive data must be prepared for the study of environmental factors, properties of materials, resistance to various environments, and the possibilities of co-storage with other types of ammunition etc. The required safety level is achieved by choosing the packaging design and materials enabling the critical environmental factors in the internal environment to be taken into consideration.

Packaging consists of a collective part that surrounds one or more units as protection against prevalent environmental stresses. Components like shock absorbers, barriers (against humidity, gases, etc.), and protection against electrical interference etc. are included herein.

There are various types of packaging for once-only (i.e. disposable) or repeated use. In some cases the packaging is designed to have a secondary function such as a launcher or other type of launch device.

4.5.1 Environmental factors

The risks of damage to packaged ammunition are determined by mechanical, electrical, chemical, climatic and biological environmental factors. The risks may exist during all phases of the life of the ammunition. If the packaging is damaged it may result in unpredictable impact on the environment.

Mechanical environmental factors comprise, for example, dynamic stresses from shock or vibration, or stresses caused by static load (such as when stacking).

Electrical environmental factors comprise, for example, electromagnetic radiation (e.g. from radio or radar transmitters), static electricity (e.g. thunderstorms or hovering helicopters), or electromagnetic pulse in conjunction with a nuclear weapon engagement, and high power pulsed microwave radiation.

Chemical environmental factors such as the effect of gases, vapours, fluids or particles in the external or internal environment can cause damage or hazardous events.

Climatic environmental factors such as extreme high or low temperatures, changes in barometric pressure, thermal shock, relative humidity, rain, hail, etc. can cause damage or hazardous events.

Biological environmental factors such as different life forms (such as rodents, insects, fungi and bacteria) can cause damage or hazardous events.

According to an EU directive, the introduction of wood from non-EU countries is regulated. This is important to consider for munitions and packaging used in international operations outside the EU. This is to avoid bringing home harmful organisms.

4.5.1.1 *Mechanical environmental stress*

Examples of the consequences of mechanical stress:

- Leaks in joints can occur through fatigue, shock or other mechanical stress.
- Cracks, debonding, explosive dust, damage to surface treatment, indications of ruptures or other degradation of material strength can occur as a result of mechanical stress or fatigue.
- Initiation of detonators containing impact-sensitive pyrotechnic compositions can occur through inadvertent impacts.

4.5.1.2 *Electrical environmental stress*

An example of the consequences of the electrical impact may be that electric igniters are inadvertently initiated. This may occur if the electrical and electromagnetic environments are more severe than the specified test level. This also applies in the case of electrostatic discharge.

4.5.1.3 *Chemical environmental stress*

An example of chemical impact may be that corrosion is caused through the action of non-compatible materials. This may occur if these substances come in contact with moisture, either through direct contact or through any gases or liquids generated.

4.5.1.4 *Climatic environmental stress*

Examples of the consequences of climatic environmental stress:

- Variations in temperature during storage can cause condensation on the surfaces of materials with high thermal capacity incurring a risk of moisture damage and corrosion, for example.
- Variations in temperature of high amplitude can cause such high stresses in materials or joints that ruptures occur.
- Air can be pumped in or out through leaks in packaging enabling moisture to be transported into the internal environment where it causes damage to the munition such as corrosion.

4.5.1.5 Other environmental impacts

An example of the consequence of other environmental impacts may be that explosive substances are initiated as a result of unintentional heating (e.g. in the event of a fire).

4.5.2 Joint requirements for packaging for ammunition

- | | |
|-------------|---|
| 1.405.001 T | The packaging shall be able to withstand the tests and meet the requirements set out in the UN Recommendations on the Transport of Dangerous Goods - Manual of Test and Criteria.
<i>Comment:</i> The requirements relate to selection of materials, packaging design, marking and labelling, etc. |
| 1.405.002 T | The packaging shall protect the ammunition against the environments to which it is predicted that the system will be subjected throughout its life. These environments are stated in the environmental specification.
<i>Comment:</i> Requirements governing the protective properties of the packaging can be related to the inherent resistance of the ammunition. Furthermore, the packaging must not create an environment the ammunition cannot withstand. |
| 1.405.003 T | Constituent materials in the packaging shall be selected and combined so that effects detrimental to safety do not occur.
<i>Comment:</i> Such effects can, for example, be caused by corrosion, incompatibility or instability. |
| 1.405.004 T | Packaging should be designed to prevent mass detonation.
<i>Comment:</i> This requirement can be achieved by adequate separation of the explosive units as well within a packaging as between packaging. |

- 1.405.005 T Packaging should be designed such that the consequences of an inadvertent initiation of the constituent explosive is limited.
Comment: In the event of a fire a propulsion device, for example, can create a ‘gun effect’ if the package is in the form of a metallic tube.
- 1.405.006 T The design of, and materials for, packaging **shall** be selected to prevent detrimental effects from handling and storage environments.
- 1.405.007 T When re-using packaging it **shall** be ensured that they from a safety aspect are equivalent to new ones.
- 1.405.008 T When selecting materials for packaging, consideration **shall** be given to the applicable regulations for recycling.
- 1.405.009 T The prescribed material recycling symbols **shall** be marked on constituent components.

4.5.3 Common requirements for ammunition in packaging

- 1.405.010 T** Packaging and their contents **shall** be F-classified (“F-coded”) in accordance with IFTEX.
- 1.405.011 T** Packaging and their contents **shall** be classified in accordance with the UN classification.
- 1.405.012 T** Packaging and their content **shall** be provided with distinct and durable markings in accordance with applicable regulations governing transport and storage to enable rapid and safe identification of the contents.
- 1.405.013 T** If it follows from the REACH Regulation (EC No. 1907/2006) that the supplier must provide a safety data sheet, this **shall** be attached to the audit documentation.
- Comment:* Reference to requirement 1.401.008 A. The safety data sheet must be designed in accordance with REACH (EC No 1907/2006). The classification should be in accordance with CLP (EC No 1272/2008). The safety data sheet must be written in Swedish, with the following accepted exceptions: if the chemical product is not placed on the Swedish market and does not have a Swedish safety data sheet, the safety data sheet must be written in English.

5

SUMMARY OF REQUIREMENTS/ CHECKLIST

5.1 COMMON

The tables on the following pages are to be used by the projects to manage compliance of the requirements.

The entire set of requirements can be downloaded as a changeable Word file on FMV's home page. The Word file includes a requirements fulfillment column.

When making presentations to FMV's advisory groups, the lists should be completed (see *Section 2.6*).

Whether a requirement is fulfilled or not, or if it is not applicable, is to be noted in the fulfilment column (Yes, No or Not applicable).

In the column "Remarks" it shall be noted as to how the requirement is fulfilled or why it is not applicable.

5.2 REQUIREMENTS IN CHAPTER 2 SAFETY ACTIVITIES AND REQUIREMENTS COMMON TO ALL EQUIPMENT

Section 2.1 Safety Activity Requirements

Req.no	Content
1.201.001 A	System safety requirements shall be specified in the Request for Proposal (RFP) in accordance with <i>Section 2.5</i> .
1.201.002 A	For explosives, advice shall be obtained from FMV's Advisory Group for Explosives. See also <i>Section 2.6.3</i> .

5 Summary of requirements/Checklist

Req.no	Content
1.201.003 A	Advice from FMV's other advisory groups for ammunition safety shall be obtained when appropriate. See <i>Section 2.6</i> .
1.201.004 A	Safety testing shall be performed by the supplier as part of the safety verification. See also <i>Section 2.7</i> .
1.201.005 A	Test directives for safety inspections (part of the In-Service Surveillance of Ammunition) shall be produced in conjunction with the procurement. See also <i>Section 2.8</i> and the <i>FMV Handbook of Regulations for In-Service Surveillance of Ammunition</i> .
1.201.006 A	Supply classification data shall be provided and registered in current register.
1.201.007 A	Draft handling, maintenance and user instructions shall be provided.
1.201.008 A	Safety Statement shall always be submitted for ammunition

Section 2.2 Requirements Common to all Equipment

Req.no	Content
1.202.001 T	Incorporated explosives shall be qualified in accordance with FSD 0214, STANAG 4170 or equivalent. <i>Comment:</i> Assessments relating to the scope of the qualification are carried out where appropriate by FMV's Advisory Group for Explosives, see <i>Section 2.6.3</i> .

Req.no	Content
1.202.002 T	<p>Incorporated materials shall be compatible so that the product remains safe during its lifetime.</p> <p><i>Comment:</i> Incompatible materials are to be avoided even if their reaction products are harmless. During compatibility testing, all of the organic materials used in the explosives along with other safety critical components are often analysed. This applies to materials that are in direct contact with each other or that can be affected via exchange of gases or liquids.</p>
1.202.003 T	<p>The product shall retain its safety properties for at least as long as its specified service life.</p>
1.202.004 T	<p>Service life and compatibility testing shall be carried out in accordance with FSD 0223 or equivalent.</p>
1.202.005 T	<p>Environmental requirements shall be specified as part of the procurement. The Defence Sector's criteria documentation shall be followed and any exceptions approved and documented.</p>
1.202.006 T	<p>When procuring or modifying ammunition or explosive goods, information and/or reference materiel shall be procured so that ammunition surveillance monitoring according to <i>FMV Handbook of Regulations for In-Service Surveillance of Ammunition (FMV H AmÖ)</i> is made possible.</p>

Section 2.3 Requirements of International Law

Req.no	Content
1.203.001 A	<p>Weapons and ammunition shall not be so designed that they violate applicable international law and conventions to which Sweden has acceded.</p> <p><i>Comment:</i> Thus, there is a ban on weapons that have an indiscriminate effect, that unnecessarily aggravate suffering or cause unnecessary damage.</p>
1.203.002 A	<p>Each project concerning the study, development, new acquisition or modification of weaponry or methods of warfare shall be reported to the Delegation for Supervision of Weapon Projects.</p> <p><i>Comment:</i> Notification to the delegation must be carried out at an early stage and in cooperation with the Armed Forces.</p>
1.203.003 A	<p>Booby traps that look like civilian utility goods, or which are marked with internationally recognised safety symbols, shall not be developed.</p>
1.203.004 A	<p>Laser weapons mainly for use against people (anti-personnel laser weapons) shall not be developed.</p>
1.203.005 A	<p>Weapons intended to poison shall not be developed.</p>
1.203.006 A	<p>Incendiary weapons that have a non-discriminatory effect, or are mainly intended for anti-personnel use, shall not be developed.</p>
1.203.007 A	<p>Weapons that are difficult to aim at a specific target shall not be developed.</p> <p><i>Comment:</i> This requirement applies, among other things, to weapons used for carpet bombing.</p>
1.203.008 A	<p>Weapons that may cause extensive, long-term, severe damage to the natural environment shall not be developed.</p>

Req.no	Content
1.203.009 A	High explosive shells designed primarily for anti-personnel purposes shall have a minimum weight of 400 grams.
1.203.010 A	Mines shall not be designed to be of similar appearance to civil utility goods, neither may they be marked with internationally recognised safety symbols.
1.203.011 A	Bullets shall not be easily expanded or flattened in the human body.
1.203.012 A	Bullets shall have a full metal jacket and not have notches (compare dum-dum bullets).

5.3 REQUIREMENTS IN CHAPTER 3 WEAPONS

Section 3.1.1 Danger Area

Req.no	Content
1.301.001 T	Based on analysis and testing, an assessment of the danger area for all current combinations of weapons, ammunition, and firing procedures shall be determined. <i>Comment:</i> Refer also to the relevant hazard, e.g. blast pressure, fragmentation, toxic substances.

Section 3.1.2 Safety of friendly forces

Req.no	Content
1.301.002 T	<p>There shall be an emergency stop function for laying and firing when the ordinary stop function is not sufficient to prevent injury to a person or damage to property.</p> <p><i>Comment:</i> Compare standard SS-EN ISO 13850:2008.</p>
1.301.003 T	<p>The emergency stop function for laying and firing should be designed and operate in such a way that the energy source can be disconnected.</p>
1.301.004 T	<p>The emergency stop function for laying and firing should be located as close to the energy source as possible.</p>
1.301.005 T	<p>It shall be possible to unload a loaded weapon (the removal of the ammunition from the chamber, magazine and equivalent).</p> <p><i>Comment:</i> Some disposable weapons are not possible to unload.</p>
1.301.006 T	<p>It should be possible to manually override automatic functions.</p>
1.301.007 T	<p>It shall be possible for gun crews to wear specified equipment while at their operator station.</p> <p><i>Comment:</i> Such equipment may comprise personal protective clothing such as gloves, a helmet, eye protectors (e.g. protective mask, anti-laser goggles) and CRBN protective clothing.</p>
1.301.008 T	<p>Monitors/VDUs should be designed to enable them to be viewed with existing lighting, even outdoors in direct sunlight or in darkness.</p>
1.301.009 T	<p>Symbols and texts on switches and other controls shall be legible and unambiguous in accordance with applicable standards.</p>

Req.no	Content
1.301.010 T	In weapon systems where several operators can fire the weapon, it shall be possible for each operator to render the weapon safe independently.
1.301.011 T	Steps and footholds shall be fitted with appropriate anti-slip surfaces.
1.301.012 T	Locking devices shall be provided to ensure that heavier hatches and doors remain in the open position, see also requirements 1.303.023 T and 1.303.024 T.
1.301.013 T	Ventilation and heating/air conditioning systems should be incorporated if applicable.
1.301.014 T	A safe separation distance shall be established for all relevant types of ammunition in the most unfavourable firing conditions. <i>Comment:</i> Protective features on the weapon are to be taken into consideration, compare requirement 1.401.028 T.
1.301.015 T	The firing mechanism shall have a transport safety device.
1.301.016 T	Firing system shall have a safety device for the transport and operating phases.
1.301.017 T	It shall be possible to render the system safe to prevent inadvertent firing during loading/unloading and during transport of the system. <i>Comment:</i> For example, it must be possible to reassemble a transport safety device.
1.301.018 T	The necessity of using a specific stance when firing a weapon shall be documented in the Safety Restrictions.
1.301.019 T	When fitting external equipment onto the weapon, consideration shall be given to the effect of possible muzzle blast.

5 Summary of requirements/Checklist

Req.no	Content
1.301.020 T	Muzzle blast shall not cause injury to the gunner.
1.301.021 T	The weapon should not produce such a muzzle blast that personal protective equipment is required for the crew.

Section 3.1.3 Toxic substances

Req.no	Content
1.301.022 T	The concentration of hazardous substances, such as air pollutants, shall be lower than the permissible values stated in AFS – Hygienic limit values.
1.301.023 T	Emissions during firing shall be documented. <i>Comment:</i> The information provides a basis for assessing how users can be exposed to chemical substances and relates to the requirements in AFS – Hygienic limit values.
1.301.024 T	Requirement 1.301.022 T shall be verified for the worst possible firing conditions and at field conditions.

Section 3.1.4 Electrical and magnetic fields

Req.no	Content
1.301.025 T	The susceptibility of electrical circuits to interference shall be analysed with regard to safety.
1.301.026 T	The levels of electrical and magnetic fields to which the crew and equipment are subjected shall be determined.

Section 3.1.5 Robustness to extreme climatic conditions

Req.no	Content
1.301.027 T	<p>Weapons shall be verified from a safety point of view for the climate zones stated in the specification for the system.</p> <p><i>Comment:</i> Stricter requirements normally apply to safety than to requirements specified for function. For data on climate, see NATO AECTP 230.</p>
1.301.028 T	<p>The design of weapons and ammunition shall be formulated in a way that handling is possible also when operators are wearing protective clothing and using other equipment.</p>

Section 3.1.6 Fire

Req.no	Content
1.301.029 T	<p>In the event of fire in a weapon platform or in equipment (ammunition or other) stowed in a confined space the crew should be protected by specific design measures and/or escape routes.</p>

Section 3.1.7 Sound pressure

Req.no	Content
1.301.030 T	<p>The sound pressure level shall be determined for the personnel concerned. Measurements shall be carried out in accordance with the Armed Forces' regulations for the measurement of impulse noise from weapons and blasting in open areas as well as in built-up areas in accordance with Armed Forces' regulations. The results of measurements form the basis for the type of personal protective equipment required and the number of exposures (rounds) the crew concerned may be subjected to over a specified period of time.</p> <p><i>Comment:</i> Regulations in accordance with HKV document ref. FM2019-25521:1 dated 2019-12-05 or equivalent replacements. The Swedish Armed Forces is conducting continuous work in this area; regulations will therefore most probably be updated. On this basis, checks have to be made to ensure that current regulations are applied. Proposals for requirements for the acquisition of new technical systems and for modification of existing systems are stated in the design rule "Requirements for sound levels and sound quality in technical systems", 14FMV10020-65:1, 2018-12-06.</p>
1.301.031 T	<p>The use of protective devices and the location of the crew relative to the launcher shall be stated in the Safety Instructions.</p>

Section 3.1.8 Back blast

Req.no	Content
1.301.032 T	The back blast (propellant gases and unexpended gunpowder) from the muzzle brake or equivalent via the rear opening during firing shall not have such high particle and energy content that it can cause injury to personnel or damage to equipment outside the specified danger area.
1.301.033 T	Requirement 1.301.032 T shall be verified by calculation and testing.

Section 3.1.9 Vibration dose

Req.no	Content
1.301.034 T	Personnel shall not be exposed to a harmful vibration dose. <i>Comment:</i> Commonly used requirements for exposure to body vibration are stated in AFS 2005:15.

Section 3.1.10 Pressure

Req.no	Content
1.301.035 T	When establishing the dimensions and design of the barrel, breech mechanism and other parts exposed to pressure, the pressure definitions and procedures stated in STANAG 4110 or equivalent standard shall be applied.

Section 3.1.11 Spring forces

Req.no	Content
1.301.036 T	It shall be possible to determine whether a spring contains stored energy.
1.301.037 T	Spring forces that alone, or in combination with other hazards, can result in an accident shall be analysed.
1.301.038 T	Spring forces that can cause an accident shall either be provided with double locking devices or protective covers that prevent inadvertent release of the spring forces.
1.301.039 T	Any spring that constitutes a component in a locking device which, in the event of malfunction, can cause injury, shall be analysed with regard to failure modes and characterised.
1.301.040 T	Fastening elements shall be analysed with regard to failure modes and characterised together with the spring.
1.301.041 T	The characteristics, according to requirements <i>1.301.039 T</i> and <i>1.301.040 T</i> , shall be maintained between inspection intervals for preventive maintenance purposes, so that safety is not impaired.
1.301.042 T	Springs and their attachment elements that can affect safety shall be protected so that inadvertent contact by personnel or the environment around the system does not degrade their safety.
1.301.043 T	Springs and their attachment elements that can cause a serious injury in the event of malfunction should have a duplicate (redundant) function or have a fail-safe function.

Section 3.1.12 Hydraulic and pneumatic forces

Req.no	Content
1.301.044 T	It shall be possible to determine whether a hydraulic or pneumatic design contains stored energy.
1.301.045 T	Accumulated pressure shall be monitored and equipped with a device for pressure equalisation if inadvertent actuation in the system can lead to injury during operation, unloading and/or maintenance.
1.301.046 T	Monitoring as specified in requirement 1.301.045 T should be duplicated (instrument and control lamp) or have a fail-safe function.
1.301.047 T	Hydraulic hoses and components should be located outside confined crew compartments.
1.301.048 T	Hydraulic fluid should be prevented from penetrating into crew compartments.

Section 3.1.13 Recoil forces

Req.no	Content
1.301.049 T	The danger area around recoiling and recoilless systems shall be determined and specified in the Safety Instructions (SI). <i>Comment:</i> The actions of the gun crew in all situations (emergency firing, unloading, etc.) are to be considered.
1.301.050 T	If overpressure can occur in the recoil brake and recuperator hence constituting a hazard, they shall be equipped with a device for relieving the pressure before disassembly.
1.301.051 T	The recoil forces in a recoilless system shall be determined by calculation and testing.

Section 3.1.14 Other forces

Req.no	Content
1.301.052 T	Rotating and other moving parts should be located so as to minimise the risk of injury. <i>Comment:</i> This requirement can be satisfied by the provision of safety guards or by preventing the presence of personnel inside the danger area.
1.301.053 T	It shall not be possible for loading devices to be controlled by anyone other than the person performing the loading.
1.301.054 T	Crew shall be protected against the ejection of empty cartridge cases.

Section 3.1.15 Lasers

Req.no	Content
1.301.055 T	The laser should be equipped with a device to ensure that it is not activated in unintentional high power mode, as the power of the laser is so high that it is justified.
1.301.056 T	It should be possible to equip high power lasers with optical attenuators.
1.301.057 T	Lasers with higher class than laser class 1 shall be equipped with warning sign. <i>Comment:</i> For lasers with physical dimensions that make marking with a warning sign impossible, the warning text must be presented in the instruction manual and marking must be done on the laser's packaging.

Req.no	Content
1.301.058 T	Sights, prism windows etc. should either have built-in laser protection filters or be designed in such a way that it allows the operators to wear laser safety goggles.
1.301.059 T	New lasers shall be delivered with a classification certificate. <i>Comment:</i> The classification is based on requirements from AFS 2009:7 with current updates and SSMFS 2014:04. Competence that ensures that classification is carried out can be found within FMV.

Section 3.1.16 Mechanical stability

Req.no	Content
1.301.060 T	The stability of the chassis, platform, controls, eye-piece, launcher etc. shall be such that there is adequate stability during firing.
1.301.061 T	It shall be possible to secure doors and hatches in the closed and open position.
1.301.062 T	Weapons/weapon platforms shall be designed so that stowed equipment and ammunition cannot move or be dislodged from their designated places during use. <i>Comment:</i> Requirements regarding resistance to mine shock are to be taken into account.

Section 3.1.17 Transport

Req.no	Content
1.301.063 T	Racks and bins shall be designed so that the environmental impact during transport and movement shall not exceed the specified robustness of the ammunition.

Section 3.2.1 **Weapon installation**

Req.no	Content
1.302.001 T	<p>Launchers controlled by electronics systems shall meet the requirements that apply to electronics and software-controlled subsystems in <i>Section 4.4.5</i> and in accordance with relevant requirements in <i>H ProgSäk</i>.</p> <p><i>Comment:</i> See also the requirements for ignition systems for propulsion devices in <i>Section 4.4.8.9</i>.</p>
1.302.002 T	<p>Clearance between the elevating system and other parts at maximum recoil within the entire laying range in traverse and elevation shall be sufficient to prevent damage to the system.</p>
1.302.003 T	<p>Protective barriers and covers should be fitted to prevent crew members from being injured by moving system parts (i.e. within the range of movement of the recoil system, etc).</p> <p><i>Comment:</i> “Dangerous area” is to be marked.</p>

Section 3.2.2 **Breech mechanisms**

Req.no	Content
1.302.004 T	<p>It shall be possible to operate the breech mechanism from outside the zone of motion of the recoil system to prevent injury to crew members by squeezing.</p>
1.302.005 T	<p>When the breech mechanism is fully closed it shall be locked in its position.</p>
1.302.006 T	<p>The breech mechanism shall not open as a result of vibration caused by firing or motion/transport.</p>
1.302.007 T	<p>It should not be possible to assemble any component of the breech mechanism in an incorrect manner that could cause injury/damage or lead to an unsafe condition.</p>

Req.no	Content
1.302.008 T	When the breech mechanism is operated automatically the firing mechanism shall automatically become inactive before the breech mechanism is released from its locked position.
1.302.009 T	It shall be possible to indicate or observe the status of the breech mechanism.
1.302.010 T	It shall not be possible to fire the weapon if the breech mechanism is not fully closed.

Section 3.2.3 Firing mechanism

Req.no	Content
1.302.011 T	It shall be possible to make the firing mechanism safe from outside the zone of motion of the recoil system.
1.302.012 T	The weapon shall be fired by an active operation from outside the zone of motion of the recoil system.
1.302.013 T	If an electromechanical device is used it shall be protected from radiated or conducted interference that could cause unintentional firing of the system.
1.302.014 T	If firing button, pedal, lever or similar device is employed it shall be provided with protection against inadvertent operation such as by a trigger guard.
1.302.015 T	Electrical firing systems shall not be susceptible to radiated or conducted interference generated by other electrical installations within the weapon system, or from external sources of interference (radio, radar etc.) that could result in inadvertent firing of the system.

5 Summary of requirements/Checklist

Req.no	Content
1.302.016 T	The firing system should be designed in such a way that the electrical connector does not make contact with the base connector of the artillery primer until intended firing.
1.302.017 T	There should be at least one mechanical safety device that directly prevents the striker from actuating. This feature should not be a part of the firing linkage.
1.302.018 T	There shall be a separate manually operated safety switch that breaks the electrical firing circuit.
1.302.019 T	The safety switch specified in requirement <i>1.302.018 T</i> shall be located outside the zone of operation of the recoil system.
1.302.020 T	The safety switch specified in requirement <i>1.302.018 T</i> shall be marked with actual position/mode such as: S for safe, P for single round, and A for automatic fire.

Section 3.2.4 Breech ring

Req.no	Content
1.302.021 T	For a given load profile, the life of the breech ring shall be established by calculation and material testing.

Section 3.2.5 Obturation

Req.no	Content
1.302.022 T	Obturation shall be designed to ensure that the crew is not exposed to either hot gases or harmful concentrations of toxic fumes.

Section 3.2.6 Secondary combustion

Req.no	Content
1.302.023 T	Secondary combustion, which may cause injury to personnel, shall not occur.

Section 3.2.7 Barrel wear

Req.no	Content
1.302.024 T	The barrel shall not constitute an increased risk (such as by imparting extra stress on ammunition or incorrect trajectory) when the ammunition in question is fired in either a new or worn barrel. <i>Comment:</i> A barrel is defined as worn when it has less than 25% left of its total service life.
1.302.025 T	Requirement 1.302.024 T shall be verified by testing.

Section 3.2.8 Barrel fatigue

Req.no	Content
1.302.026 T	Fatigue life span shall be determined and verified. Theoretical calculations may be used. <i>Comment:</i> See STANAG 4516 and STANAG 4517.

Section 3.2.9 Barrel rupture

Req.no	Content
1.302.027 T	The barrel shall not rupture when firing with a specified amount of snow, sand or gravel in the barrel.
1.302.028 T	Requirement 1.302.027 T should be verified by testing. <i>Comment:</i> The requirement applies primarily to small-calibre weapons but if the system is used in such a way that there is a high probability that foreign matter may enter the barrel it may also apply to larger calibre weapons. Testing is performed by filling the barrel with various quantities of sand and gravel to determine the durability of the weapon.

Section 3.2.10 Cook-off

Req.no	Content
1.302.029 T	Cook-off shall not occur during the maximum specified fire engagement in combination with jamming involving rammed ammunition. <i>Comment:</i> Refer also to requirements 1.401.020 T, 1.402.011 T and 1.403.019 T.
1.302.030 T	To determine the risk of cook-off, the temperature and heat flux etc. for a hot barrel shall be established. <i>Comment:</i> The Safety Restrictions must state the permitted rate of fire, the permitted number of rounds per salvo, and/or the permitted duration for fire. If different types of ammunition are used in the weapon, this should be taken into account in the test. Refer also to requirement 1.401.019 T.

Section 3.2.12 Muzzle brakes, flame guards and recoil amplifiers

Req.no	Content
1.302.031 T	The muzzle brake should prevent rearward ricochets of driving bands, sabots, obturators, etc.
1.302.032 T	During modification in the design, or new development, of ammunition or weapons relating to driving bands, sabots, obturators, jackets etc., or in the event of changed rifling pitch in the barrel or a new muzzle brake, testing shall be performed to determine the occurrence of fragmentation.

Section 3.2.13 Muzzle flash

Req.no	Content
1.302.033 T	When fitting external equipment onto the weapon or weapon platform, consideration shall be given to the effect of possible muzzle flash.

Section 3.2.14 Sub-calibre barrels

Req.no	Content
1.302.034 T	Applicable requirements stated in <i>section 3.2.7–3.2.10</i> above shall apply.
1.302.035 T	It shall not be possible for a correctly fitted sub-calibre barrel to detach during firing.
1.302.036 T	It shall be possible to inspect a sub-calibre barrel for cracks and other defects.

Req.no	Content
1.302.037 T	<p>Sub-calibre barrels shall not produce different levels of stress on ammunition, if the barrel length of the practice weapon differs from its original design.</p> <p><i>Comment:</i> If, for example, a sub-calibre barrel is longer than a standard barrel, other acceleration and spin stresses may arise. It must be determined whether the ammunition is designed for such stresses.</p>
1.302.038 T	<p>Requirements 1.302.035 T and 1.302.037 T shall be verified by test firing using the actual propelling charges and types of ammunition.</p>

Section 3.2.15 Ramming

Req.no	Content
1.302.039 T	<p>The rammer should be provided with safety devices that prevent injury to personnel.</p>
1.302.040 T	<p>The ramming environment for the weapon in question shall be verified by testing. Testing shall also be performed at the extreme temperatures that are specified as a basis for the requirements of the ammunition.</p> <p><i>Comment:</i> Compare requirement 1.404.037 T.</p>

Req.no	Content
1.302.041 T	<p>During driving in terrain in accordance with specified conditions, the ammunition should not fall back from the rammed position.</p> <p><i>Comment:</i> This requirement should be verified by testing with a barrel that has 50% or less of its service life remaining in terms of wear.</p>
1.302.042 T	<p>The system should withstand rounds being fired with ammunition that is not rammed in a correct manner (i.e. in fall-back position).</p> <p><i>Comment:</i> Gas leakage around the ammunition can damage both the ammunition and the barrel. Compare requirement 1.401.015 T.</p>

Section 3.2.16 Recoil brakes

Req.no	Content
1.302.043 T	The system shall be designed so that the static pressure of the recoil buffer is retained.
1.302.044 T	Leakage of recoil buffer fluid and gas should be minimised.
1.302.045 T	The design of the recoil brake shall be of such type, quality and dimension that the required safety margin against exceeding the maximum permitted recoil stress exists in all specified environments.
1.302.046 T	Maximum recoil stresses shall be verified.
1.302.047 T	Forced recoil equipment shall withstand recoil forces with a safety margin.
1.302.048 T	<p>If gas dampers are included in the recoil system, there shall be indication for recoil brake pressure.</p> <p><i>Comment:</i> The requirement refers to, among other things, inspection before shooting and preparation for maintenance.</p>

Section 3.2.17 Composite and compound barrels

Req.no	Content
1.302.049 T	When designing non-metallic and compound barrels, consideration shall be given to expected changes over time of material properties.
1.302.050 T	When designing fastening of external parts onto non-metallic barrels, consideration should be given to the influence of mountings that are permanently attached for example by winding, so that elongation properties are not negatively affected.

Section 3.2.18 Recoilless weapons and rocket systems

Req.no	Content
1.302.051 T	Applicable requirements stated in <i>Section 3.2.3</i> above shall apply.
1.302.052 T	Any residual recoil for recoilless launch tubes and rocket systems should be directed rearwards.
1.302.053 T	Recoil forces shall be established. This can be carried out by means of calculation and/or testing.
1.302.054 T	Back blast from a recoilless weapon, rocket or missile motor shall not cause injury to the operator/crew.
1.302.055 T	Requirement <i>1.302.054 T</i> shall be verified by testing.

Section 3.3.1 Minelayers for anti-tank mines

Req.no	Content
1.303.001 T	If the minelayer arms the mine via a mechanical device it shall be equipped with an automatic monitoring system.

Req.no	Content
1.303.002 T	A monitoring system as specified in requirement 1.303.001 T, shall emit both a light and sound signal when a mine becomes jammed in the minelayer. The alarm shall be reset manually.
1.303.003 T	A minelayer that mechanically arms the mine shall enable access to a mine that becomes jammed without the necessity for the use of any tools.
1.303.004 T	It shall be possible to decouple a minelayer that mechanically arms the mine from the towing vehicle to enable personnel and the towing vehicle to be moved out of the danger area of the mine within the duration of the safety delay including a safety margin. <i>Comment:</i> If the above safety delay is 5+1 minutes it should be possible to decouple the minelayer from the towing vehicle and to move the personnel (with vehicle) outside the mine's danger area within two minutes.
1.303.005 T	The minelayer should be designed so as to minimise the risk of a mine becoming jammed during laying. <i>Comment:</i> The shape of the mine should also be taken into consideration.

Section 3.3.2 Launching equipment for underwater mines/
depth charges

Req.no	Content
1.303.006 T	The launching equipment shall not arm the mine before the mine leaves the mine laying device.
1.303.007 T	The launching equipment shall be designed so that the mine cannot jam during launch. <i>Comment:</i> The configuration of the mine is also to be taken into account, see requirement 1.401.027 T.
1.303.008 T	For self-propelled mines and torpedo mines that are launched or dropped from surface vessels, submarines or helicopters, requirements in accordance with <i>Section 3.3.3</i> , launching devices for torpedoes and <i>Section 3.3.4</i> , beams and shovels shall apply.

Section 3.3.3 Launch devices for torpedoes

Req.no	Content
1.303.009 T	Torpedo tubes shall be equipped with sensors that indicate that the torpedo has left the tube after it has been launched.
1.303.010 T	Torpedo tubes shall be so designed that the torpedo cannot jam on its way out of the tube or in the torpedo room of submarines. <i>Comment:</i> The design of the torpedo is also to be taken into account.
1.303.011 T	It shall not be possible for the testing of a launcher to cause inadvertent launch. <i>Comment:</i> The test system is normally separated from the launch system.

Req.no	Content
1.303.012 T	Power up (such as at system check, simulation or before launch) of a torpedo shall not lead to inadvertent launch.
1.303.013 T	For torpedoes incorporating hydrogen peroxide, the torpedo tubes and standby storage shall be equipped with a draining system connected to the hydrogen peroxide system of the torpedo.
1.303.014 T	Material and components used in the drainage system shall be chosen so that they are compatible with highly concentrated hydrogen peroxide. <i>Comment:</i> See instructions and requirements in HANDBOK VÄTEPEROXID, M7780-252981.
1.303.015 T	The drainage system shall be designed for the maximum number of torpedoes used on board. <i>Comment:</i> When designing/dimensioning drainage systems on board submarines, the probability of abnormal decay of VP85 must be taken into account. See also instructions and requirements in HANDBOK VÄTEPEROXID, M7780-2529811.
1.303.016 T	In an emergency situation, it shall be possible to jettison the torpedoes from a helicopter, emergency launch from a surface vessel and emergency launch with the use of a separate back-up firing panel from a submarine.
1.303.017 T	For torpedoes, requirements 1.302.001 T and 1.302.018 T shall apply.

Section 3.3.4 Launchers and pylons

Req.no	Content
1.303.018 T	A pylon/launcher shall enable a transport safety device in the form of an indicator or equivalent to be clearly visible while the munition is in transport safe mode.

5 Summary of requirements/Checklist

Req.no	Content
1.303.019 T	A pylon/ launcher as specified in requirement 1.303.018 T should enable the transport safety device to be carried together with the munition. <i>Comment:</i> This enables replacement of the transport safety device if the aircraft lands at a different site from the ammunition preparation site.
1.303.020 T	Pylons/launchers shall enable separation of the weapon system or munition in such a way that there is no risk of collision with weapon platforms. <i>Comment:</i> This includes incorrect manoeuvring of the ammunition.

Section 3.3.5 Weapon platforms

Req.no	Content
1.303.021 T	The platform shall satisfy applicable traffic regulations for civil and military use. <i>Comment:</i> Dispensation may be given.
1.303.022 T	Sound pressure from the launch/firing shall be acceptable for the crew. Verification is required, see <i>Section 3.1.7</i> .

Section 3.3.6 Openings/hatches and doors

Req.no	Content
1.303.023 T	The locking/bolt mechanism shall be designed to withstand the stresses arising during operational use.

Req.no	Content
1.303.024 T	The locking/bolt mechanism should be accessible and manoeuvrable from both inside and outside.
1.303.025 T	Locks on hatches and doors should be manoeuvrable by crew wearing regulated personal protective equipment at all extreme temperatures.

Section 3.3.7 Sights and aiming systems

Req.no	Content
1.303.026 T	There shall be devices to prevent the armament being aimed or fired in prohibited directions such as towards fixed obstacles. <i>Comment:</i> During maintenance, it is permissible to aim in prohibited directions.

Section 3.3.8 Guidance and control systems

Req.no	Content
1.303.027 T	Sources of radiation aimed at the launch unit from the guided weapon/munition should be so designed that they do not require any danger zones at the launch unit.
1.303.028 T	Sources of radiation for guidance that can have a dangerous effect shall be indicated to the operator when transmission is in progress.
1.303.029 T	During exercises the indication specified in requirement 1.303.028 T should also be visible to anyone anywhere in the vicinity.
1.303.030 T	It shall not be possible for guidance signals to the weapon/munition to initiate motor or warhead igniters.

5 Summary of requirements/Checklist

Req.no	Content
1.303.031 T	<p>The guided weapon/munition should incorporate a function which, in the event of a target miss, or if a malfunction is detected which definitively precludes effect in the target, renders the weapon safe.</p> <p><i>Comment:</i> This can be achieved, for example, by self-neutralisation, self-destruction, or sterilisation.</p>
1.303.032 T	<p>There should be a system for function monitoring and fault detection for the guidance system. This may result in self-neutralisation or sterilisation of the weapon, etc.</p>
1.303.033 T	<p>The guidance system shall be designed and documented in a way that enables a safety analysis to be performed.</p>
1.303.034 T ^a	<p>The safety analysis shall be performed or audited by a party that is independent of the designer.</p> <p><i>Comment:</i> Another department or special safety function within the same company may be considered as an independent party.</p>
1.303.035 T	<p>All materials incorporated shall be selected and combined in such a way that effects detrimental to safety do not arise during the life of the guidance system, for example as a result of corrosion, ageing, chemical change or short-circuits.</p>
1.303.036 T	<p>Data transfer between the weapon and fire control, both before and after launch, should conform to standardised communication protocols.</p>
1.303.037 T	<p>Data transfer between the weapon and fire control, both before and after launch, shall be subject to function monitoring.</p> <p><i>Comment:</i> Function monitoring can, for example, be by means of parity checking or a ‘watch-dog’ function.</p>

- a. Please note that this requirement was given the wrong number (1.303.033 instead of 1.303.034) in the printed, Swedish version, July, 2020. However, this has been corrected in the digital edition and requirement checklist.

Section 3.4.1 Pressure vessels

Req.no	Content
1.304.001 T	Pressure vessels shall be type approved in accordance with the Swedish Work Environment Authority's regulations.

Section 3.4.2 Lifting devices

Req.no	Content
1.304.002 T	<p>Lifting devices intended for use in military equipment shall undergo a process similar to that of the CE marking.</p> <p><i>Comment:</i> The process is the same as for CE marking of products according to EU directives, with the only difference that the products that follow the process are not marked with the letters "CE" on the product's nameplate. See also <i>H SystSäk</i>, the Machinery Directive, and AFS.</p>
1.304.003 T	<p>The danger area for a lifting device shall be established and taken into consideration when formulating Safety Restrictions.</p> <p><i>Comment:</i> The danger area is greater than the area immediately beneath a hanging load, for example.</p>

5.4 REQUIREMENTS IN CHAPTER 4 AMMUNITION

Section 4.1.1 Insensitive Munitions (IM)

Req.no	Content
1.401.001 A	<p>During procurement, overhaul, or modernisation of ammunition for the Swedish Armed Forces, ammunition with sufficient IM properties shall be considered.</p> <p><i>Comment:</i> The desired IM properties are to be assessed in each case with regard to the threat, the desired effect (performance), the risk of injury and cost. Requirements for IM properties are to be established in the Armed Forces' Operational Requirements (SMS).</p>
1.401.002 A	<p>The potential threats that an ammunition item could be subjected to should be determined with the help of a THA (Threat Hazard Analysis) which covers all the phases in the service life of the munition.</p> <p><i>Comment:</i> For each individual threat, it is necessary to identify what tests has to be conducted and the type of reactions that may be permitted in order to verify the desired level of insensitivity. The work is carried out in accordance with STANAG 4439 and AOP-39. If threats are detected which are not defined in STANAG 4439, these should also be addressed.</p>

Section 4.1.3 Batteries

Req.no	Content
1.401.003 T	<p>When designing weapon systems or ammunition with batteries, hazards with regard to batteries shall be analysed and reported.</p> <p><i>Comment:</i> Risk of injury due to high current and voltage levels, short circuit, leakage and more are to be taken into account.</p>
1.401.004 T	<p>The structure and operating principle of batteries shall be reported, among other things, with regard to the constituent chemical substances and quantities thereof.</p> <p><i>Comment:</i> Chemical substances in batteries can affect transport classification and the possibility of co-storage, as well as measures required by chemical legislation.</p>
1.401.005 T	<p>Every project that intends to use batteries in a design shall get assurance from an accredited authority about the possibility of co-storage with explosive goods.</p> <p><i>Comment:</i> In addition to risks with stored chemical energy, there may also be risks with leakage of battery electrolyte over time and compatibility problems with other substances, for example with explosive goods and risks of self-ignition.</p>
1.401.006 T	<p>High temperatures generated by batteries in normal operation shall be considered and verified in the application where they are intended to operate.</p> <p><i>Comment:</i> Placing batteries near explosive products can lead to hazard ignition of the explosive, poorly thermally protected cabling can lead to short circuits and more.</p>

Section 4.1.4 Chemical legislation and FMV's chemical management

Req.no	Content
1.401.007 A	<p>With reference to the REACH Regulation (EC No 1907/2006), the supplier shall classify the ammunition as:</p> <ol style="list-style-type: none"> a substance or mixture, or a combination of an article and a substance / mixture, or an article.
1.401.008 A	<p>Based on the classification of the ammunition according to requirement 1.401.007 A, the supplier shall inform about how obligations imposed by the Reach regulation are handled, and submit such information or documentation that follows from imposed obligations.</p> <p><i>Comment:</i> Documentation can, for example, be safety data sheets or substances included in the candidate list.</p>
1.401.009 T	<p>With reference to the CLP Regulation (EC No 1272/2008), the ammunition shall be labeled in accordance with CLP, if the ammunition is covered by the aforementioned Regulation.</p>
1.401.010 A	<p>Information on chemical substances included in the ammunition shall be documented as follows:</p> <ol style="list-style-type: none"> Chemical name of the substance CAS number Concentration (percentage by weight). <p><i>Comment:</i> The information is to be documented, for example in current register or in the appendix Environmental Plan to System Life Cycle Plan (SLCP).</p>

Req.no	Content
1.401.011 A	<p>Information whether the ammunition contains a Candidate List substance, present in a concentration above 0.1% by weight, shall be documented. As a minimum, the name of the substance and CAS number for the substance in question shall be documented.</p> <p><i>Comment:</i> The information is to be documented, for example in the Basic and Management Data or in the appendix Environmental Plan to System Life Cycle Plan (SLCP).</p>
1.401.012 A	<p>Information whether the ammunition contains a substance included in Annex XIV to Reach shall be documented.</p> <p>If the substance included in Annex XIV requires an authorization for use, the supplier shall inform how the obligations imposed by the REACH Regulation are handled, when relevant.</p> <p><i>Comment:</i> The information is to be documented, for example in current register or in the appendix Environmental Plan to System Life Cycle Plan (SLCP).</p>
1.401.013 A	<p>Emissions to the surrounding environment in connection with the effects of the ammunition shall be mapped to a sufficient extent to support the needs of the Swedish Armed Forces.</p> <p><i>Comment:</i> The information provides a basis for assessing the environmental impact on firing ranges, etc., which may have a bearing on the Swedish Armed Forces’/FMV’s environmental permit.</p>

Section 4.1.5 Other ammunition common requirements

Req.no	Content
1.401.014 T	<p>Data for assessment of the danger area shall be created for all combinations of launchers and ammunition.</p> <p><i>Comment:</i> Data is created by analysis and tests, for example with respect to the danger area for lasers, shrapnel, thermal radiation, and sound pressure etc.</p>
1.401.015 T	<p>The projectile and propelling charge shall be designed so that the projectile remains in the rammed position with the gun at maximum elevation without any special devices being needed on the gun.</p> <p><i>Comment:</i> The above applies for ammunition where ramming is desirable. This is particularly important when the projectile and propelling charge are separated. See also <i>Section 3.2.15</i>.</p>
1.401.016 T	<p>The function stated in requirement <i>1.401.015 T</i> shall be tested using a worn barrel.</p> <p><i>Comment:</i> Refer to the definition of a worn barrel.</p>
1.401.017 T	<p>Ammunition should be designed so that clearing/unloading can be performed in a safe manner by the crew operating the weapon.</p> <p><i>Comment:</i> This also applies to clearing/unloading after an ammunition misfire.</p>
1.401.018 T	<p>Verification of requirement <i>1.401.017 T</i> shall include testing of what forces can be permitted for the unloading tool in question.</p> <p><i>Comment:</i> Testing also includes the force required to achieve clearing/unloading.</p>

Req.no	Content
1.401.019 T	To establish the risk of cook-off for the ammunition, the temperature/heat flux etc. for a barrel at its maximum operating temperature and for the shell shall be determined. Refer also to requirements 1.302.029 T and 1.302.030 T.
1.401.020 T	Driving bands, casings or equivalent shall be designed so that they do not inadvertently disintegrate outside the barrel when firing.
1.401.021 T	Sabots and separating driving bands shall be designed to ensure safe separation. <i>Comment:</i> The risk of sabot fragments and any change in projectile trajectory has to be considered.
1.401.022 T	Driving bands, sabots, obturators, casings etc. should be designed so that no fragments are formed that can impact the muzzle brake (if fitted) and ricochet rearwards.
1.401.023 T	Projectile shall be designed to achieve external ballistic stability in all permitted types of firing so that specified danger areas are still valid. <i>Comment:</i> Worn barrels, driving bands, fins etc. can affect external ballistics.
1.401.024 T	Explosives incorporated in the ammunition shall be qualified in accordance with FSD 0214 or with applicable international standard, such as STANAG 4170. <i>Comment:</i> Assessments concerning the scope of qualification can be made by the Advisory Group for Explosives (Rg Expl), see <i>Section 2.6.3</i> .

5 Summary of requirements/Checklist

Req.no	Content
1.401.025 T	<p>The ammunition should be able to withstand abnormal environments such as accidents or the effects of enemy fire so that together with the system's safety measures, it contributes by making the vulnerability of the system as low as possible.</p> <p><i>Comment:</i> The above is to be based on the robustness of the ammunition and the protection level of the system. Compare STANAG 4439. See also <i>Section 4.1.1, Insensitive Munitions (IM)</i>.</p>
1.401.026 T	<p>Torpedoes shall be designed so that they do not jam in launch tubes. Compare requirement <i>1.303.010 T</i>.</p>
1.401.027 T	<p>Landmines, underwater mines and depth charges shall be designed so that they don't interfere with or get stucked in mine-laying equipment. Compare requirement <i>1.303.007 T</i>.</p>
1.401.028 T	<p>The safe separation distance/time shall be established for the severest case of operational use. Refer also to requirements <i>1.301.014 T</i>, <i>1.402.021 T</i>, <i>1.403.007 T</i> and <i>1.404.014 T</i>.</p>
1.401.029 T	<p>The design and the materials used in munition shall be chosen to enable the casing to withstand all stresses arising, including pressure in the barrel, without exceeding acceptable deformation.</p> <p><i>Comment:</i> In the design of the ammunition the pressure definitions and procedures stated in STANAG 4110 are to be applied.</p>
1.401.030 T	<p>Incorporated materials shall be compatible.</p> <p><i>Comment:</i> See also requirement <i>1.202.002 T</i>.</p>

Section 4.2.2 Joint requirements for warheads

Req.no	Content
1.402.001 T	Warheads of CBRN type (chemical, biological, radioactive, or nuclear weapons) shall not be developed.
1.402.002 T	Warheads, in which fuel is sprayed into the air and detonates owing to the oxygen in the air and where the main purpose is anti-personnel, should not be developed. <i>Comment:</i> Must meet requirements 1.203.001 A and 1.203.006 A regarding the prohibition of indiscriminate effect and firearms. May also produce effects equivalent to chemical weapons in cases where the gas is toxic and does not ignite, which is also prohibited, see requirement 1.402.001 T.
1.402.003 T	Warhead casings whose main effect is fragmentation shall be made of material that can be easily detected by X-ray.
1.402.004 T	Multiple weapons and guided weapons shall be considered as several warheads and propulsion devices. Separation charges and guidance or trajectory correction motors shall be treated as propulsion devices.
1.402.005 T	The design of and the materials used in the warhead shall be chosen to enable the casing to withstand all stresses arising, including pressure in the barrel, without exceeding acceptable deformation. <i>Comment:</i> Example of detailed requirements stipulated: Safety margin for deformation, freedom from cracks, overlaps, pores or incorrect heat treatment that can lead to hazardous events. With regard to pressure in the barrel, refer to <i>Chapter3</i> .

Req.no	Content
1.402.006 T	When tempered steel is used in the casing the material and heat treatment chosen shall be such that hydrogen embrittlement or other dangerous corrosion does not occur.
1.402.007 T	The internal surface of the casing shall be smooth and clean. <i>Comment:</i> The warhead casing must be protected from moisture and foreign particles before casting/filling of the explosive.
1.402.008 T	The design and composition of HE charge (High Explosive charge) and pyrotechnic charge shall be such that they can withstand all stresses arising without any risk of a hazardous event occurring. <i>Comment:</i> Testing is carried out in accordance with FSD 0060 or other relevant international standard. See also <i>Section 4.1.1, Insensitive Munitions (IM)</i> .
1.402.009 T	The warhead shall be designed to avoid the presence of high explosive or pyrotechnic composition in threads or joints in such a quantity as to create a risk of inadvertent initiation when screwing components on or off or at launch or release.
1.402.010 T	Requirements 1.402.008 T and 1.402.009 T shall be verified by testing. <i>Comment:</i> The parts in the warhead can be examined prior to testing by using X-ray, radiography, ultrasonic testing or other methods.
1.402.011 T	The warhead shall not be susceptible to cook-off in the event of a misfire or interruption in firing when the barrel is at its maximum operating temperature for the operational profile in question. <i>Comment:</i> Refer also to requirements 1.302.029 T and 1.403.019 T.

Req.no	Content
1.402.012 T	The melting point of the high explosive should be higher than the temperature reached by the ammunition in a barrel heated to its maximum operating temperature for the operational profile in question.
1.402.013 T	The warhead in its application should not detonate in the event of fire. <i>Comment:</i> This requirement is part of the IM requirements defined in STANAG 4376. See also requirements 1.401.001 A and 1.401.002 A.
1.402.014 T	Requirement 1.402.013 T should be verified by testing.
1.402.015 T	The warhead in its application should not detonate from bullet attack from small calibre ammunition. <i>Comment:</i> This requirement is part of the IM requirements defined in STANAG 4376. See also requirements 1.401.001 A and 1.401.002 A.
1.402.016 T	Requirement 1.402.015 T should be verified by testing.
1.402.017 T	The design of the warhead shall facilitate upgrading, in-service surveillance and disposal.
1.402.018 T	The possible identification and destruction of UXO (unexploded ammunition) shall be taken into account during the design of the warhead.
1.402.019 T	The blast pressure from a detonating warhead shall be determined to be used to calculate the danger area. <i>Comment:</i> This applies, among other things, to hand grenades, thunder flashes and spotting charges. See also <i>Section 3.1.7</i> . For applications in underwater environments, see <i>FM Reglemente Sjösäkerhet vapen; M7739-353134^a</i> .

5 Summary of requirements/Checklist

Req.no	Content
1.402.020 A	Environmental aspects arising from manufacture, use and clearance of UXO (unexploded ammunition), recovery of target materiel, and disposal shall be taken into account. <i>Comment:</i> The information is documented in the appendix Environmental plan to System Life Cycle Plan (SLCP).
1.402.021 T	A safe separation distance shall be established for all warheads, see also requirement 1.401.028 T.
a.	Armed Forces' Regulations for Maritime Safety Weapons

Section 4.2.3.1 Warheads containing High Explosive (HE)

Req.no	Content
1.402.022 T	If it is likely that the material from which the shell body is fabricated may contain pipes, a base plate or equivalent shall be employed and be attached in a satisfactory manner.
1.402.023 T	When filling a shell body with high explosive it shall be ensured that unacceptable pipes, cavities, gaps or cracks do not occur and that required adhesion is achieved. <i>Comment:</i> The level of defects; quantity, size, etc., must be dealt with in each item according to the explosive chosen and environment specific requirements.
1.402.024 T	Requirement 1.402.023 T shall be verified by X-ray inspection, sawing the shell bodies, or by the use of bisectable shell bodies.
1.402.025 T	Pressed shell bodies shall be free from explosive dust.

Req.no	Content
1.402.026 T	<p>Pressed explosive bodies shall keep the prescribed freedom from unacceptable defects such as cracks.</p> <p>When pressing explosive bodies, it shall be ensured that unacceptable defects (for example cracks) do not occur.</p> <p><i>Comment:</i> Levels regarding defects, number, size and so on must be taken care of in each individual object with regard to the selected explosive and environment specific requirements.</p>
1.402.027 T	<p>Any joints or splits in the hell body shall be satisfactorily sealed to prevent explosives in the joint/ split and to prevent hot propellants from reaching the explosive.</p>
1.402.028 T	<p>When installing a primary charge it shall be ensured that no cavity occurs that could cause inadvertent initiation.</p>
1.402.029 T	<p>In shells equipped with an end screw or base fuze, the charge in the shell shall be well filled against the base of the shell.</p>
1.402.030 T	<p>In shells fitted with a base-bleed unit, any uncontrolled base-bleed combustion shall not lead to deflagration or detonation of the warhead.</p>

Section 4.2.3.2 High explosive warheads for rockets and guided missile

Req.no	Content
1.402.031 T	<p>The warhead casing should not consist of separate parts within the zone adjacent to the rocket motor in order to avoid gas leakage.</p>
1.402.032 T	<p>The HE charge in the warhead should be protected from heat-generating components.</p>

Section 4.2.3.3 High explosive warheads for bombs

Req.no	Content
1.402.033 T	If the casing consists of separate parts, there shall be a sufficiently good seal to ensure that the ingress of moisture or the leakage of explosive does not occur.
1.402.034 T	Where separated charges are used the intervening space shall be filled with an appropriate filler material.

Section 4.2.3.4 High explosive warheads for land mines

Req.no	Content
1.402.035 T	If the casing consists of separate parts there shall be sealing to prevent the ingress of moisture.
1.402.036 T	Metal casings shall be protected against corrosion.

Section 4.2.3.5 Warheads containing high explosive for depth charges, underwater mines and torpedoes

Req.no	Content
1.402.037 T	If there is a risk of overpressure in the warhead it shall be possible to remove plugs or other seals without risk of injury to personnel, such as during in-service surveillance of ammunition.
1.402.038 T	Fuzes that are installed from the outside shall form a seal with the casing or have a sealed seat/location.
1.402.039 T	Metal casings shall be protected against corrosion internally and externally.

Req.no	Content
1.402.040 T	Where separate charges are used, any intervening space shall be filled with an appropriate filler material.
1.402.041 T	Explosives in warheads shall , when adequate sealing cannot be guaranteed, be compatible with surrounding media. <i>Comment:</i> This should be taken into account even if good sealing can be guarantee.
1.402.042 T	Explosives in warheads should be easy to inspect with respect to environmental impact, such as moisture. <i>Comment:</i> This especially applies to ammunition that is intended to be used internationally and then returned to Sweden.

Section 4.2.3.6 High explosive warheads for other ammunition

Req.no	Content
1.402.043 T	Ammunition should be such that co-storage and joint transportation with other types of ammunition are in accordance with IFTEX and the 'UN Recommendations on Transport of Dangerous Goods, Model Regulations' can be permitted. <i>Comment:</i> Choice of packaging can affect the classification.

Section 4.2.4 Pyrotechnic warheads

Req.no	Content
1.402.044 T	Pyrotechnic ammunition should be designed and the compositions selected such that co-storage with other types of ammunition in accordance with IFTEX and the 'UN Recommendations on the Transport of Dangerous Goods, Model Regulations' can be permitted.
1.402.045 T	The charge shall meet the prescribed moisture content.
1.402.046 T	The charge shall meet the prescribed purity from foreign particles.
1.402.047 T	The pyrotechnic composition used should have good storage stability.
1.402.048 T	Compressed pellets shall meet the prescribed structural strength.
1.402.049 T	Insulation adhesion shall meet the prescribed value.
1.402.050 T	Requirement 1.402.049 T shall be verified by testing, if necessary by destructive testing.
1.402.051 T	Insulation shall be free from cracks, cavities and symmetry deviations.
1.402.052 T	The charge casing shall be sealed.

Section 4.2.4.1 Pyrotechnic warheads for tube-launched ammunition

Req.no	Content
1.402.053 T	The base of the shell shall be completely sealed against hot propellant gases, moisture etc. and against composition dust.
1.402.054 T	At final assembly the charge shall have the correct moisture content. <i>Comment:</i> If necessary the charge may need to be dried before final assembly.

Section 4.2.4.2 Pyrotechnic warheads for rockets and bombs

Req.no	Content
1.402.055 T	The dividing wall (partition) between the warhead and rocket motor shall be sealed and insulated so that ignition of the composition does not occur through the ingress of propellant gases or by heat transmission.
1.402.056 T	At final assembly the charge shall have the correct moisture content. <i>Comment:</i> If necessary the charge may need to be dried before final assembly.

Section 4.2.5 Other warheads

Req.no	Content
1.402.057 T	Applicable parts of the requirements specified for pyrotechnic charges in <i>Section 4.2.4</i> shall apply.

Section 4.3.2 Joint requirements for launching and propulsion systems

Req.no	Content
1.403.001 T	The design of, and materials in, a propelling charge casing shall be selected so as to ensure that the casing resists all specified loads without exceeding the permissible deformation or stress.
1.403.002 T	Adjacent materials, and materials in the propellant, shall be compatible. These materials may comprise internal protective paint, sealing agents, insulation materials, combustion catalysts, wear protectants, etc. Refer also to requirements 1.202.002 T, 1.202.003 T and 1.202.004 T.
1.403.003 T	When using hardened steel the material and heat treatment chosen shall be such that neither hydrogen brittleness nor detrimental corrosion occurs.
1.403.004 T	The propelling charge shall be of a type, quality, and size to ensure that the required safety margin for permissible maximum pressure in all specified environments is not exceeded. <i>Comment:</i> The requirement applies to both tube-launched ammunition (limited by the strength of the barrel) and rocket motors (limited by the strength of the casing), see also the guideline text in the first paragraph in <i>Section 4.3</i> .
1.403.005 T	The propulsion force development and pressure–time curves shall be reproducible within the stated requirement specification.
1.403.006 T	Propelling charge should be designed to minimise fragments propelled rearwards from e.g. the base plate or nozzle plug.
1.403.007 T	The safe separation distance/time shall be established for all propulsion systems for the most unfavourable operating conditions. Refer also to requirement 1.402.017 T.

Req.no	Content
1.403.008 T	Metal additives, if any, shall not be able to block the exhaust nozzle.
1.403.009 T	The propelling charge casing shall be sealed as required.
1.403.010 T	The propelling charge casing shall withstand handling throughout its service life.
1.403.011 T	The composition of the propellant should be such that itself, its components and its combustion products are of minimal toxicity and have as little environmental impact as possible. This applies to manufacture, use, clearance of UXO and disposal. <i>Comment:</i> See also <i>Section 4.1.4.</i>
1.403.012 T	The design should facilitate disassembly (e.g. for upgrading, in-service surveillance and disposal).
1.403.013 T	The propulsion device in its tactical application should not detonate when subjected to the specified attack from bullets, fragments etc. <i>Comment:</i> This requirement is part of the IM requirements defined in STANAG 4439.
1.403.014 T	Requirement <i>1.403.013 T</i> should be verified by testing.
1.403.015 T	The propulsion device in its tactical application should not detonate if subjected to fire. <i>Comment:</i> Compare also general IM requirements.
1.403.016 T	A fuel fire test should be performed to verify requirement <i>1.403.015 T</i> .

Section 4.3.3 Propulsion devices in tube-launched ammunition

Req.no	Content
1.403.017 T	<p>Within the permitted temperature range the propelling charge shall produce a pressure (MOP) that is lower than the permitted maximum value for the barrel and shell.</p> <p><i>Comment:</i> In the design of the ammunition the pressure definitions and procedures stated in STANAG 4110 must be applied.</p>
1.403.018 T	<p>For recoiling barrels the combustion of the propelling charge should be designed so that the charge has burnt out before the projectile exits the muzzle. This is to avoid giving rise to back-flash/secondary combustion when the weapon's breach is opened.</p>
1.403.019 T	<p>Maximum fire engagement with regard to the risk of cook-off when firing is interrupted for a barrel at its maximum operating temperature shall be determined.</p> <p><i>Comment:</i> Refer also to requirement 1.302.029 T.</p>
1.403.020 T	<p>The cartridge case shall seal against the chamber seat so that unpermitted gas leakage does not occur.</p>
1.403.021 T	<p>When using percussion caps in artillery primers etc., the impact surface shall be countersunk so that the risk for inadvertent initiation during use is minimised.</p>

Section 4.3.4.1 Solid propellant rocket motors and gas generators

Req.no	Content
1.403.022 T	<p>Propulsion devices should be designed such that the pressure vessel does not burst or detonate as a result of the impact of shrapnel from fragment-forming ammunition (or equivalent).</p> <p><i>Comment:</i> This requirement is part of the IM requirements defined in STANAG 4439.</p>
1.403.023 T	<p>Propulsion devices should be designed such that if the pressure vessel bursts a minimum of dangerous fragments are formed.</p>
1.403.024 T	<p>Propulsion devices shall, with regard given to transport and storage, be designed such that a specified fire does not cause uncontrolled flight.</p>
1.403.025 T	<p>Propulsion devices containing propellants with metallic powder shall be analysed with regard to risks in the event of electrostatic charging.</p>

Section 4.3.4.2 Liquid propellant rocket engines and gas generators

Req.no	Content
1.403.026 T	<p>Requirements 1.403.015 T, 1.403.016 T, 1.403.022 T and 1.403.023 T shall apply.</p>
1.403.027 T	<p>The tank system shall be designed such that direct contact between propellants cannot occur inadvertently.</p>
1.403.028 T	<p>Tanks for propellants shall have adequate space for the expansion of the liquids.</p>

5 Summary of requirements/Checklist

Req.no	Content
1.403.029 T	Leakage of propellants shall not cause the engine to start.
1.403.030 T	Leakage of propellants shall not cause the pressure vessel to burst.

Section 4.3.4.3 Jet engines

Req.no	Content
1.403.031 T	Requirements <i>1.403.013 T</i> , <i>1.403.015 T</i> , <i>1.403.016 T</i> and <i>1.403.022 T</i> shall apply.
1.403.032 T	The quantity and size of discarded parts (debris) at the start of ramjet function should be minimised.
1.403.033 T	The number of components containing pyrotechnic or explosive charges should be minimised.

Section 4.3.4.4 Ram rocket engines

Req.no	Content
1.403.034 T	Requirements <i>1.403.013 T</i> , <i>1.403.015 T</i> , <i>1.403.016 T</i> , <i>1.403.022 T</i> , <i>1.403.032 T</i> and <i>1.403.033 T</i> shall apply as should requirement for ram rocket engines.
1.403.035 T	Fire tests for verification of requirement <i>1.403.015 T</i> shall be carried out for ram rocket engines.

Section 4.3.4.5 Propulsion devices for torpedoes, self-propelled mines, and torpedo mines

Req.no	Content
1.403.036 T	Requirements 1.403.005 T, 1.403.015 T, 1.403.016 T, 1.403.022 T, 1.403.023 T, 1.403.027 T and 1.403.028 T shall all be applied as shall-requirements for torpedo systems.
1.403.037 T	Water leakage or battery failure shall not lead to the inadvertent start of the torpedo.
1.403.038 T	Torpedoes shall be designed in such a way that any inadvertent contact between battery acid and explosives does not occur.
1.403.039 T	Short circuits which can lead to a battery explosion shall not be able to occur.
1.403.040 T	Explosive gases formed during the self-discharge or charging of batteries shall be ventilated away and/or disposed of in order to avoid initialisation occurring.

Section 4.3.4.6 Systems for highly concentrated hydrogen peroxide

Req.no	Content
1.403.041 T	Highly concentrated hydrogen peroxide (HTP) shall meet quality requirements and undergo regular inspections specified in <i>HANDBOK VÄTEPEROXID</i> , M7780-252981.
1.403.042 T	HTP tanks shall be equipped with adequate relief and drainage devices.
1.403.043 T	Materials in HTP tanks shall not contain catalytic substances that can lead to a reaction by HP.

Req.no	Content
1.403.044 T	Spaces in buildings or on board vessels where HTP or HTP-filled torpedoes are handled or stored shall be designed in accordance with the instructions and requirements in <i>HANDBOK VÄTEPEROXID</i> , M7780-252981.
1.403.045 T	Materials and components included in systems that store or consume HTP or handle the drainage of HTP shall be designed in accordance with the instructions and requirements in <i>HANDBOK VÄTEPEROXID</i> , M7780-252981.
1.403.046 T	HTP shall meet quality requirements and undergo regular inspections specified in <i>HANDBOK VÄTEPEROXID</i> , M7780-252981.

Section 4.4.2.1 Design requirements

Req.no	Content
1.404.001 T	Fuzing systems shall be designed to enable safety analysis to be performed.
1.404.002 T	The safety level of the fuzing system should be specified numerically as a probability and should be verified by analysis. <i>Comment:</i> An analysis can be carried out with the help of the FTA (Fault Tree Analysis) and FMECA (Fault Modes, Effects and Criticality Analysis).
1.404.003 T	Single failures that can lead to inadvertent initiation of explosives after the interrupter or circuit safety device within the arming distance/time shall not occur. <i>Comment:</i> For some applications, the requirement for redundancy to prevent inadvertent initiation can be resolved so that a system failure results in a fail-safe state.

Req.no	Content
1.404.004 T	<p>Explosive trains containing primary explosives or sensitive explosives (not approved for use after an interrupter) shall have at least one mechanical interrupter. Only explosives in accordance with requirement 1.404.005 T are permitted after that interrupter.</p> <p><i>Comment:</i> Refer also to requirements 1.404.142 T, 1.404.143 T and 1.404.144 T.</p>
1.404.005 T	<p>Explosives after the interrupter or for use in systems without an interrupter shall be qualified for such use as specified in FSD 0214 or STANAG 4170 or other relevant international standard.</p>
1.404.006 T	<p>Fuzing systems should not contain stored energy, such as mechanical, pyrotechnical or electrical, for removing the interrupter towards an armed position in the explosive train.</p> <p><i>Comment:</i> Energy for removing an interrupter can best be provided by some unique environmental factor after launch/release.</p>
1.404.007 T	<p>Stored energy shall not be used for both disabling safety features and removing interrupters.</p>
1.404.008 T	<p>The probability of inadvertent initiation of an explosive after the interrupter or circuit safety device shall not be higher than the probability for inadvertent arming.</p> <p><i>Comment:</i> A failure must thus not lead to initiation unless all the steps normally required for arming have been completed.</p>
1.404.009 T	<p>Encapsulation of the explosive train shall be designed such that hazard initiation of the explosive train before the interrupter while the interrupter is in unarmed mode does not lead to ejection of fragments or other effects that can cause injury or damage to personnel, property or the environment.</p>

Req.no	Content
1.404.010 T	Fuzing systems shall be designed and documented in such a manner as to facilitate an effective production control and quality inspection.
1.404.011 T	All constituent materials shall be selected and combined such that no effects detrimental to safety occur during the life of the fuzing system, e.g. as a result of corrosion, mechanical fatigue, mutual interference, or insufficient chemical stability resulting in the formation of copper azide for example.
1.404.012 T	All explosives shall be encapsulated and/or be fixed so that they remain intact when subjected to specified environmental severities.
1.404.013 T	The initiator in the ignition system shall not inadvertently be triggered by a specific external environmental factor such as electrical, mechanical or climatic.
1.404.014 T	<p>The safe separation distance/time shall be established with regard to warhead effect and intended tactical use. Refer also to requirements 1.301.014 T and 1.401.028 T.</p> <p><i>Comment:</i> Three different cases can be identified:</p> <ol style="list-style-type: none"> a. The safe separation distance is so great that the risk to friendly forces is tolerable in the event of a burst occurring when that distance has been reached. No evasive action is assumed. b. The safe separation distance is shorter than in case a. above owing to tactical reasons. Evasive action or taking cover is assumed. c. The safe separation time is sufficiently long to allow for leaving the danger area. <p>See definition of safety distance/time in <i>Appendix 1 Definitions</i>.</p>

Req.no	Content
1.404.015 T	<p>Fuzing systems should be designed so that a failure in the system results in a fail-safe state.</p> <p><i>Comment:</i> This requirement can lead to a degradation of any deactivation or self-destruction function.</p>
1.404.016 T	<p>Fuzing systems should be designed such that incorrect assembly of safety-critical parts is not possible.</p>
1.404.017 T	<p>The possibility of final assembly of, or installing, a fuzing system when armed shall be prevented. This is achieved when at least one of the following conditions are met.</p> <ol style="list-style-type: none"> <li data-bbox="501 706 1125 802">a. It shall be so designed that during manufacture it is not be possible to complete the assembly of an armed fuzing system. <li data-bbox="501 813 1125 910">b. It shall be so designed that installing a fuzing system when armed on the ammunition is not possible. <li data-bbox="501 921 1125 1017">c. It shall be equipped with an indicator which clearly indicates whether the fuzing system is armed or safe. <p><i>Comment:</i> Arming may have occurred without being detected as a result of incorrect assembly during manufacture or maintenance, or because the SAI/SAU was not returned to its safe state after final testing.</p>
1.404.018 T	<p>If there is a requirement for system testing after manufacture (AUR testing), functions for reliable testing shall be built into the fuzing system so that tests can be carried out in a safe manner.</p>
1.404.019 T	<p>Fuzing systems shall be designed so that maintenance, upgrading, in-service surveillance, disposal and destruction can be carried out safely.</p> <p><i>Comment:</i> Necessary instructions etc. for dismantling has to be prepared during the development work.</p>

5 Summary of requirements/Checklist

Req.no	Content
1.404.020 T	The composition and integration of the booster should be such that it does not detonate or deflagrate before the main charge when subjected to heating (e.g. by fire).
1.404.021 T	Well-proven components should be used.
1.404.022 T	Arming shall occur, at the earliest, when the safe separation distance/time is reached.
1.404.023 T	The arming process should be as simple as possible.
1.404.024 T	The arming process should be functionally and physically separated from other processes in the system.
1.404.025 T	Inadvertent arming shall be prevented by at least two mutually independent safety features. <i>Comment:</i> The safety features can be: a. mechanical safety features in an interrupter, b. mechanically operated electric switches, c. relays, d. semiconductor switches.
1.404.026 T	If a system with only two safety features is used, both shall be mechanical.

Section 4.4.2.2 Requirements regarding testing

Req.no	Content
1.404.027 T	Constituent components and subsystems that are vital to the safety of the fuzing system shall undergo separate safety qualification (type testing).
1.404.028 T	Fuzing systems shall undergo safety qualification as specified in FSD 0213, STANAG 4157 or equivalent. <i>Comment:</i> Safety-critical functions should be monitored during testing and be inspected after testing.
1.404.029 T	Testing shall be performed at a safety level at which arming is not permitted. <i>Comment:</i> Safety level, in this case, means the stress level which exceeds, by an acceptable margin, the most severe level reached during transport, operation, ramming or the firing/launch process. Testing is intended to verify requirement 1.404.037 T. See also comment to requirement 1.404.039 T.
1.404.030 T	The choice of materials in a fuzing system shall , if it is considered necessary, be verified by testing that demonstrates with acceptable probability that no effects detrimental to safety occur during the life of the fuzing system. Refer also to requirements 1.202.002 T, 1.202.003 T and 1.202.004 T.

Req.no	Content
1.404.031 T	<p>Testing shall be performed to demonstrate whether the design used for encapsulation of the explosives meets the stipulated requirements.</p> <p><i>Comment:</i> With this testing, dimensions, compacting pressure and other properties are selected within their respective tolerance range such that the probability for failures is considered to be highest. Testing is to be performed in the environment (within the operating range of the fuzing system) that is considered to be the most unfavourable from a safety aspect.</p>
1.404.032 T	<p>Testing shall be performed to verify that the fuzing system does not initiate within the safe separation distance/time owing to passage through mask, impact with the sea surface, contact with the seabed, broaching, or collision with objects.</p> <p><i>Comment:</i> The concept of ‘inherent safety’ is used for torpedoes.</p>
1.404.033 T	<p>Testing shall be performed to establish the distance or time from launch or equivalent at which the transmission safety feature arms. If there are other safety features in the explosive train, they shall be removed prior to testing.</p>
1.404.034 T	<p>Testing shall be performed to verify that the fuzing system does not initiate in flight or after deployment after the arming process is completed as a result of the environmental stress specified in the requirement specification for the object.</p> <p><i>Comment:</i> This requirement applies primarily to ammunition with a split danger area.</p>
1.404.035 T	<p>Fuzing systems shall be designed to enable the required functional testing to be performed safely.</p>

Section 4.4.2.3 Requirements for systems with access to application-specific environmental factors

Req.no	Content
1.404.036 T	Fuzing systems should be designed so that safety is not dependent upon operating procedures.
1.404.037 T	Arming shall only be possible during use. <i>Comment:</i> The lower limit for arming must exceed, by a good margin, the maximum stress level experienced during operation, transport and other relevant environmental conditions.
1.404.038 T	Arming shall only take place if two mutually independent, application-specific, environmental conditions are satisfied, provided that reasonable such conditions are available. <i>Comment:</i> Examples are stated below of environmental conditions that can be used to activate arming and/or as sources for arming energy: <ul style="list-style-type: none"> a. acceleration, b. angular acceleration, c. spin, d. sensing of launching/mine-laying device (e.g. barrel bore-ride). This is not considered as a good condition, but may be accepted, e. dynamic pressure, f. drag (via a turbine or parachute for example), g. hydrodynamic and hydrostatic pressure, h. lanyards, i. back pressure. All conditions to be considered before the most suitable are selected.

Req.no	Content
1.404.039 T	<p>If only one realistic environmental condition is available, or two dependent conditions, there shall be at least one manual operation (such as removal of a safety pin) required for arming prior to loading/launching.</p> <p><i>Comment:</i> When safety relies entirely on one environmental condition after the manual operation has been performed, a major effort must be made to verify practically and theoretically that this condition cannot occur inadvertently after the manual operation, such as if a shell is dropped during loading.</p>
1.404.040 T	<p>A manual operation or safety pin shall also block the function controlled by the only available environmental condition.</p>
1.404.041 T	<p>At least one of the safety features shall lock the interrupter during the arming phase until the munition has left the launcher/laying device.</p>
1.404.042 T	<p>In systems with one or more unique application-specific environmental conditions available, at least one of these shall be used. At least one of the safety features shall be removed after the launcher/release device has been cleared and the safe separation distance has been reached.</p>

Section 4.4.2.4§Requirements for systems without access to unique application-specific environmental factors

Req.no	Content
1.404.043 T	If a fuzing system requires human intervention to start the arming process, there shall be a device that provides unambiguous indication of whether the system is in the safe state.
1.404.044 T	During mechanical deployment of ammunition (such as when laying mines with a minelayer) the arming shall take place at the earliest when the mine leaves the laying device.
1.404.045 T	Fuzing systems shall be designed such that the packaged ammunition and fuzing systems remain safe during storage, transport, handling and use. This applies until the point in time when the ammunition is deployed, or when the fuzing system or initiator is installed and arming or activation is performed in accordance with the specified operating instructions.
1.404.046 T	Incorrect installation of a fuzing system should not be possible.
1.404.048 T	At least two different and almost simultaneous manual operations shall be required for arming to take place. <i>Comment:</i> These manual operations should be sequential, i.e. carried out in a predefined order.
1.404.049 T	Electric ignition energy shall not occur in the firing circuit until after the specified arming delay or safe separation time has elapsed.
1.404.050 T	Fuzing systems shall be equipped with a device which, after arming, provides sufficient safety time for the operator to leave the danger zone.

5 Summary of requirements/Checklist

Req.no	Content
1.404.051 T	The probability of incorrect connection of fuzing systems to explosives, signal and spotting charges owing to a mistake, clumsiness or carelessness shall be taken into account.
1.404.052 T	In cases where safety is based on operational procedures, operating instructions shall accompany the packaging or the ammunition.
1.404.053 T	The fuzing system and components of the fuzing system shall be designed such that installation of the initiator can be performed as the final operation in the readiness procedure.
1.404.054 T	An intentional manual operation, such as removing a safety pin, shall be necessary before initiation of the warhead can take place. <i>Comment:</i> The safety pin is to be designed so that it is not inadvertently removed during normal handling of the ammunition.
1.404.055 T	The initiation device for demolition charges shall be designed so that the connected system can be disassembled safely after connection and be re-used if so stipulated.
1.404.056 T	When the application permits, fuzing systems for demolition charges should incorporate an interrupter that is remotely controlled from the initiation device.
1.404.057 T	Time fuzes should incorporate an interrupter that arms after the fuze is set and after personnel have taken cover. The initiation device is armed when the interrupter is removed from the explosive train. <i>Comment:</i> Where application-specific environmental conditions are available (such as hydrostatic pressure for underwater time fuzes) they have to be used. For other time fuzes manual time-delayed arming, for example, can be used.

Req.no	Content
1.404.058 T	Ignition cables shall be long enough to enable connection of the initiation device without it being necessary for personnel to be inside the danger area of the warhead.
1.404.059 T	If requirement 1.404.057 T cannot be met, the initiation device shall incorporate a time function that provides a delay in arming of sufficient duration to enable the operator to leave the danger area or take cover.
1.404.060 T	Initiation devices should be designed so that the risk of ignition failure is minimised. <i>Comment:</i> Consequently, it should be equipped with a continuity tester and an indicator to show that it can deliver sufficient ignition energy.
1.404.061 T	To minimise the risk of inadvertent initiation, initiation devices shall be designed so that at least two manual operations are required to enable firing.
1.404.062 T	There shall be at least one mechanical/galvanic interrupter in the firing circuits of initiation devices. <i>Comment:</i> The output on the initiation device can also be short-circuited up to the moment of firing (e.g. by one or more electromechanical switches).

Section 4.4.2.5 Neutralisation, deactivation, recovery and disposal

Req.no	Content
1.404.063 T	Firing capacitors shall be equipped with duplicate discharge (bleeder) circuits. At least one of these circuits shall be physically located as close to the firing capacitor as possible.
1.404.064 T	The leakage resistance of firing capacitors, or for grounding in twin conductor systems, shall be as low as the system permits.
1.404.065 T	Fuzing systems incorporating a deactivating function shall contain a device that indicates in an unambiguous way whether the system is safe.
1.404.066 T	Deactivation shall provide at least the same level of safety as when the system was initially in safe mode.
1.404.067 T	Deactivation should not require special tools.
1.404.068 T	Deactivation should remove all initiation energy.
1.404.069 T	The fuzing system should be designed such that deactivation/neutralisation is not prevented by a malfunction in any part of the fuzing system that is not used for deactivation/neutralisation.
1.404.070 T	If clearance for disposal or recycling is intended the fuzing system shall be designed for subsequent safe handling.

Section 4.4.2.6 Requirements of International Law

Req.no	Content
1.404.071 T	Land mines shall have a self-destruction, neutralisation or deactivation function that renders the mine safe after a certain time. This function can be automatic or remotely controlled.
1.404.072 T	Drifting mines shall have fuzing systems that ensures that the mine is rendered safe one hour after deployment at the latest.
1.404.073 T	Moored mines shall be neutralised as soon as the mine is no longer moored.
1.404.074 T	Torpedoes shall be neutralised if they do not hit the target.
1.404.075 T	<p>For ammunition with submunitions, these shall meet the requirements of the “Convention on Cluster Munitions”.</p> <p><i>Comment:</i> The definition of Cluster Munitions includes all ammunition with explosive submunitions under 20 kilograms weight. Ammunition is explicitly excluded from the definition of cluster munitions which, “in order to avoid indiscriminate effect over a surface”, has the following five characteristics:</p> <ul style="list-style-type: none"> • the ammunition consists of less than ten explosive submunitions, • each explosive submunition weighs more than four kilograms, • each explosive submunition is designed to detect and strike a single target, • each explosive submunition has an electronic self-destruct mechanism, • each explosive submunition is equipped with electronic deactivation.

5 Summary of requirements/Checklist

Req.no	Content
1.404.076 T	Submunitions shall be equipped with auto-destruction. <i>Comment:</i> See requirements in <i>Clause 4</i> of the Convention's definition in requirement 1.404.075 T above.
1.404.077 T	Submunitions shall be equipped with a neutralisation/sterilisation function which renders the submunition safe after a certain period of time.

Section 4.4.3 Mechanical subsystems

Req.no	Content
1.404.078 T	The interrupter shall prevent the booster charge in the fuzing system from initiating in the event of an inadvertent initiation of the explosive train before the interrupter.
1.404.079 T	The interrupter shall , in the safe position, be locked by at least two independent safety features.
1.404.080 T	The interrupter in an explosive train should, before arming, remove the sensitive explosive (out-of-line) from the explosive train.
1.404.081 T	Each of the safety features shall individually retain the interrupter in the safe position.
1.404.082 T	Safety features in an interrupter should lock directly into the interrupter, not via any linkage or similar device.
1.404.083 T	Testing shall be performed to establish that an interrupter remains locked in the safe position with sufficient margin when subjected to the most severe load (Compare the environmental specification) when only one safety feature is installed. The safety features are to be tested separately.

Req.no	Content
1.404.084 T	<p>Testing shall be performed to establish that explosives located after the interrupter are not initiated by the detonator while the safety device is in the safe state.</p> <p><i>Comment:</i> The following is to be taken into consideration:</p> <ul style="list-style-type: none"> • the critical thickness of a mechanical barrier, • the critical charge quantity and compacting pressure of a detonator located before the interrupter, • the critical gap and dimensions etc. of gas passages through or around the interrupter. The term ‘critical’ denotes the value when transmission in some form takes place. Testing can be supplemented by calculations.
1.404.085 T	<p>Testing shall be performed to determine at which point transmission is achieved when the interrupter is gradually moved from safe to armed position. Dimensions shall be chosen within each tolerance range so as to facilitate transmission. Between safe position and the limit position for transmission, any ejection of fragments, deformation or fragmentation shall not entail a risk of injury.</p> <p><i>Comment:</i> For interrupters with an instantaneous arming motion, testing can be performed in fewer positions (at least one) between safe and armed positions.</p>

Section 4.4.4 Electrical subsystems

Req.no	Content
1.404.086 T	Fuzing systems should not be capable of accumulating sufficient energy to initiate the warhead within the safe separation distance/time.
1.404.087 T	Connector pins in external connectors connected to an EED should be semi-enclosed.
1.404.088 T	The casing of an external connector should make contact and provide electromagnetic shielding before the pins engage.
1.404.089 T	The shielding of ignition cables should be connected to the casing of the connector around the complete circumference of the cable. <i>Comment:</i> This is particularly important with the casing of an EED to obtain good high frequency protection. The connection pins in a connector should not be used to connect shields.
1.404.090 T	The switch that finally connects an EED to the electric supply should be located as close to the initiator as possible.
1.404.091 T	The lead/leads between the switch and the EED shall be shielded from external electromagnetic fields and be protected against static electricity.
1.404.092 T	The capacitance across the switch should be kept sufficiently low to prevent initiation by electrostatic discharge.
1.404.093 T	Twin conductors should be twisted.
1.404.094 T	If one pole of an EED is grounded, the ground path should be as short as possible to the shield that surrounds it.
1.404.095 T	Ignition cables shall not be located in the same shield as other conductors.

Req.no	Content
1.404.096 T	An EED shall be tested according to FSD 0112, STANAG 4560 or equivalent.
1.404.097 T	Fuzing systems containing EEDs shall be system tested in accordance with FSD 0212, STANAG 4157 or equivalent.
1.404.098 T	EED used in fuzing systems with an in-line explosive train intended for warheads shall have an ignition voltage of at least 500 V.
1.404.099 T	When two electric signals are used for arming at least one of them shall be dependent on a continuous current supply.
1.404.100 T	If the current supply ceases before arming is completed the fuzing system shall be neutralised or deactivated.
1.404.101 T	In a system where the arming process is controlled by electrical safety features, at least two of them shall be in the form of an interruption from the current supply.
1.404.102 T	Fuzing systems in which arming is performed by connecting the circuit to earth/ground (single conductor system) should be avoided.
1.404.103 T	Arming shall not occur as a result of plausible short circuits such as short circuits between adjacent leads in harnesses, in connectors, on PCBs and in integrated circuits.
1.404.104 T	Arming shall not occur as a result of a plausible interruptions caused by, for example, soldering defects, oxidised connector surfaces, or cracks in PCBs or substrates.
1.404.105 T	For systems with only semiconductors as safety features, at least three independent ‘closings’ shall be required at system block level for arming. <i>Comment:</i> The closings are best actuated by different signal levels.

Req.no	Content
1.404.106 T	<p>A system containing only semiconductors shall not be able to arm as a result of static failures in the safety features (failure mode either closed or open), which can mean that at least one of the safety features requires a dynamic signal.</p> <p><i>Comment:</i> The dynamic signal must be of such a nature that it cannot reasonably occur inadvertently.</p>
1.404.107 T	<p>The safety analysis of a fuzing system shall be performed by at least one independent party. For system solutions with semiconductors only, the analysis should be performed by at least two independent parties.</p> <p><i>Comment:</i> A special system safety function within the company that designed the system can be considered to be an independent party.</p>
1.404.108 T	<p>A fuzing system with an in-line explosive train intended for warheads shall be initiated only by a signal that is unique and cannot be emulated by any undesired internal or external signal.</p> <p><i>Comment:</i> Usually only high power systems (such as EFI) are used in systems containing only electronic fuzes.</p>
1.404.109 T	<p>Charging of a firing capacitor or equivalent should only be started after the safe separation distance/time has been reached.</p>
1.404.110 T	<p>The voltage of a firing capacitor or equivalent shall be below the lower initiation voltage (maximum-no-fire) until the arming distance/time is reached.</p> <p><i>Comment:</i> This is analogous to the conventional case with one interrupter that moves slowly and enables transmission in the explosive train at some point before final position. Complete arming is achieved when the voltage of the firing capacitor reaches the minimum-all-fire level of the electric igniter.</p>

Section 4.4.5 Electronic and software controlled subsystems

Req.no	Content
1.404.111 T	All safety-critical functions in electronic circuits shall be implemented in firmware or hardware.
1.404.112 T	It shall not be possible to easily change the software after it has been installed in the circuit.

Section 4.4.5.1 Radioactive impact

Req.no	Content
1.404.113 T	Data in firmware shall not be able to be changed by any environmental impact which the system can otherwise withstand. Environmental impact includes the effects of radiation.

Section 4.4.5.2 Redundancy

Req.no	Content
1.404.114 T	If all safety features are implemented with logic circuits, at least two of these shall be implemented with different types of logic circuits.

Section 4.4.5.3 Unused features and environmental durability

Req.no	Content
1.404.115 T	The component manufacturer's specifications and recommendations shall be followed. <i>Comment:</i> The requirement may for example be verified by minutes from completed design reviews.

Section 4.4.5.4 Risk of short circuits

Req.no	Content
1.404.116 T	The design shall be such that the likelihood of short circuits occurring at circuit board level is minimised. <i>Comment:</i> The use of lead-based solder is in conflict with the RoHS Directive.

Section 4.4.5.5 Competence of the supplier

Req.no	Content
1.404.117 T	At least two people at the manufacturer shall in detail be familiar with the functionality of the hardware and software, as well as what tests that have been carried out on the system.

Section 4.4.5.6 Service life of stored information

Req.no	Content
1.404.118 T	The content of the memory circuits shall have a service life that with a margin exceeds the system's projected service life if reprogramming (Refresh) is not possible. <i>Comment:</i> Service life relates to both how long a memory cell can retain its information in the current operational profile (measured in years), and the number of write operations that can be performed on each individual memory cell.

Section 4.4.5.7 Power supply

Req.no	Content
1.404.119 T	The power supply for the logic system that implements safety features shall be designed so that a fault in the power supply does not result in one or more safety features being removed.

Section 4.4.5.8 System restart, RESET

Req.no	Content
1.404.120 T	The system shall assume a safe state at disturbances in the power supply and at start and stop.

Section 4.4.5.9 Self-test

Req.no	Content
1.404.121 T	After start, a self-test shall be carried out which verifies the function and condition of as many safety-critical components as possible with regard to time and performance requirements.

Section 4.4.5.10 Program flow control, Watch Dog Timer (WDT)

Req.no	Content
1.404.122 T	Programmable circuits shall have a monitoring function that puts the system in a safe state if the program execution is disrupted.

Section 4.4.5.11 *Software*

Req.no	Content
1.404.123 A	Software development shall be carried out systematically and in accordance with a recognised standard or manual. The choice of developing standard shall be presented and justified.
1.404.124 A	For safety-critical systems, software and development methodology shall be reviewed by an independent third party. <i>Comment:</i> An independent auditor may be a person in the same company that developed the software, but who was not involved in the development.
1.404.125 T	Configuration control shall be implemented for all developed software and the revision identification can preferably be included as a constant in the program memory or as a label on the circuit board.
1.404.126 T	Software for safety-critical systems shall be designed and documented so that it is possible to analyse its function.
1.404.127 T	The developed software shall be tested extensively. The choice of test method shall be documented and justified.
1.404.128 T	Software in safety-critical systems shall be as straightforward as possible.
1.404.129 T	Interrupts shall not be able to cause stack overflow, disruptions to the program execution, inadvertent changes to variables, or a non-deterministic behaviour.
1.404.130 T	The program execution shall be deterministic. <i>Comment:</i> An example of a deterministic system is a state machine where each new state is predictable and only depends on the current state and input signals.

Req.no	Content
1.404.131 T	All interrupt vectors shall be defined and the vectors that are not used shall lead to a safe state, such as RESET.
1.404.132 T	Registers that are important for the function shall be verified during operation.
1.404.133 T	If an error is detected during a self-test or during operation, a planned action shall be available and performed.
1.404.134 T	All input signals to the processor shall be assessed for reasonability.
1.404.135 T	Code that will never be used, so-called dead or dormant code, shall not be present.
1.404.136 T	Unused memory space shall be programmed with code so a jump to such space results in a safe state, e.g. a restart.
1.404.137 T	All indexed memory operations shall be checked so that the index assumes permitted values.
1.404.138 T	One, two or three bit errors shall not be able to lead to dangerous malfunction in the software, for example arming of an ignition system.
1.404.139 T	Arming shall require that a sequence is executed where the previous state is a necessary condition for the subsequent arming condition to be executed.

Section 4.4.6 Subsystems with wave-borne signals

Req.no	Content
1.404.140 T	In systems with wave-borne signals the probability of unauthorized arming/influence shall be sufficiently low with regard to the field of application.
1.404.141 T	If a signal outside the ammunition is used for arming, the fuzing system shall verify the signal before arming takes place.

Section 4.4.8.9 Propulsion devices

Req.no	Content
1.404.142 T	There shall be a transmission safety device in the explosive train of propulsion devices if inadvertent initiation of the propelling charge leads to activation of the fuzing system in the warhead. <i>Comment:</i> Guidelines as to when the transmission safety device must exist in other cases, for example when an inadvertent initiation can cause great harm, can be found in STANAG 4368.
1.404.143 T	The electric igniter in the propulsion device shall be sufficiently insensitive so as not to be initiated leading to inadvertent initiation by any radiated interference or static electricity. <i>Comment:</i> The aim must be that an electric igniter can be subjected to a current of 1 A and a power of 1 W for a minimum duration of five minutes. An analysis of the safety of the complete safety and arming system must, however, as a rule be carried out.
1.404.144 T	The explosive in a booster charge after an interrupter, or in an initiator in a system without an interrupter, should not be more sensitive than the explosives in the propelling charge.

Req.no	Content
1.404.145 T	It should be possible to install the fuzing system into a propulsion device as late as possible before operation.
1.404.146 T	It should be possible to check easily whether the fuzing system is installed in a propulsion device.
1.404.147 T	The fuzing system should be easily accessible for replacement.
1.404.148 T	The fuzing system shall be designed so that normal firing takes place within the specified time-frame (i.e. abnormal delay is prevented).

Section 4.5.2 Joint requirements for packaging for ammunition

Req.no	Content
1.405.001 T	<p>The packaging shall be able to withstand the tests and meet the requirements set out in the UN Recommendations on the Transport of Dangerous Goods - Manual of Test and Criteria.</p> <p><i>Comment:</i> The requirements relate to selection of materials, packaging design, marking and labelling, etc.</p>
1.405.002 T	<p>The packaging shall protect the ammunition against the environments to which it is predicted that the system will be subjected throughout its life. These environments are stated in the environmental specification.</p> <p><i>Comment:</i> Requirements governing the protective properties of the packaging can be related to the inherent resistance of the ammunition. Furthermore, the packaging must not create an environment the ammunition cannot withstand.</p>

5 Summary of requirements/Checklist

Req.no	Content
1.405.003 T	<p>Constituent materials in the packaging shall be selected and combined so that effects detrimental to safety do not occur.</p> <p><i>Comment:</i> Such effects can, for example, be caused by corrosion, incompatibility or instability.</p>
1.405.004 T	<p>Packaging should be designed to prevent mass detonation.</p> <p><i>Comment:</i> This requirement can be achieved by adequate separation of the explosive units as well within a packaging as between packaging.</p>
1.405.005 T	<p>Packaging should be designed such that the consequences of an inadvertent initiation of the constituent explosive is limited.</p> <p><i>Comment:</i> In the event of a fire a propulsion device, for example, can create a 'gun effect' if the package is in the form of a metallic tube.</p>
1.405.006 T	<p>The design of, and materials for, packaging shall be selected to prevent detrimental effects from handling and storage environments.</p>
1.405.007 T	<p>When re-using packaging it shall be ensured that they from a safety aspect are equivalent to new ones.</p>
1.405.008 T	<p>When selecting materials for packaging, consideration shall be given to the applicable regulations for recycling.</p>
1.405.009 T	<p>The prescribed material recycling symbols shall be marked on constituent components.</p>

Section 4.5.3 Common requirements for ammunition in packaging

Req.no	Content
1.405.010 T	Packaging and their contents shall be F-classified (“F-coded”) in accordance with IFTEX.
1.405.011 T	Packaging and their contents shall be classified in accordance with the UN classification.
1.405.012 T	Packaging and their content shall be provided with distinct and durable markings in accordance with applicable regulations governing transport and storage to enable rapid and safe identification of the contents.
1.405.013 T	<p>If it follows from the REACH Regulation (EC No. 1907/2006) that the supplier must provide a safety data sheet, this shall be attached to the audit documentation.</p> <p><i>Comment:</i> Reference to requirement 1.401.008 A. The safety data sheet must be designed in accordance with REACH (EC No 1907/2006). The classification should be in accordance with CLP (EC No 1272/2008). The safety data sheet must be written in Swedish, with the following accepted exceptions: if the chemical product is not placed on the Swedish market and does not have a Swedish safety data sheet, the safety data sheet must be written in English.</p>

Appendix 1 Definitions

This section lists the nomenclature and acronyms used in this.

Terminology

Ablation, *Ablation*

Evaporation of surface material by the impact of flowing hot gases.

Comment: Ablation is a method for protecting objects against for example aerodynamic heating (e.g. space vehicles on re-entry into the atmosphere).

Adiabatic compression, *Adiabatisk kompression*

A compression which takes place with no or minimal exchange of heat with the surroundings.

Ageing, *Åldring*

The ageing of materials involves a continuous change through time of properties (chemical and physical such as sensitivity, rate of combustion and mechanical strength).

Aiming and firing limitation / Laying and firing limitation, *Rikt- och avfyringsbegränsning (ROA)*

Aiming and firing limitation is a system integrated into the weapon to prevent aiming in certain sectors (so as not to hit nearby obstacles for example), and to prevent firing in other specific sectors (to prevent hitting weapon platforms or friendly forces for example).

All Up Round-testing, AUR

Complete ammunition (weapon, robot, torpedo or other ammunition).

Comment: The term is primarily used for testing.

Ammunition, *Ammunition*

Equipment that is intended for damage, deployment of smoke and gas, fire and light effects, blasting, mining, mine clearance, signaling and marking, and equipment that replaces this equipment during training. The equipment may contain explosives or other special chemical substances. Sometimes the packaging and manufacturing details are also defined as ammunition.

Ammunition safety, *Ammunitionssäkerhet*

Ammunition safety is the property of ammunition that enables the ammunition – under specified conditions – to be transported, kept in depot storage, used, and disposed of without a hazardous event taking place, and without constituent parts in the ammunition being affected in such a way that a hazardous event occurs.

Arm, *Armera*

To remove safety features in safety device(s) to enable initiation.

Comment: In a system with an out-of-line explosive train, arming occurs when the interrupter has been removed and an initiation can result in fuzing system function. In an in-line system arming occurs when the minimum level for ignition energy has been reached and only the initiation signal remains for initiation to take place.

Arming device, *Armerdon, armeringsdon*

Refer to the entry for '*Transmission Safety Device*'.

Arming range, Arming distance, Arming time, *Armeringsavstånd, -distans, -tid*

The range (distance/time) from the launcher (or releasing device) until the point or point in time where/when the fuze is armed.

Artillery primer, Tändskruv

An igniting device of the same design and function as a cannon primer. An artillery primer is usually threaded and is used to ignite a propulsion agent confined in a cartridge case or separate case, in the rear plane of which there is a seat for the artillery primer.

Comment: In cases where the priming device is fixed by means of compressing it is often incorrectly referred to as a cannon primer.

Assemble, Aptera

To assemble/install individually manufactured ammunition components containing explosives.

Auxiliary Booster, Primärladdning

An amplifying charge applied to the main charge (for example by gluing, casting or screwing on) of pressed explosive, intended to ensure the initiation of the main charge.

Back blast, Bakåtstråle

The rearward blast of (hot) propulsion gases which, when a weapon is fired, escape from the muzzle brake of recoil weapons and from the aft opening (nozzle) of recoilless weapons. The blast may contain fragments from the ammunition and particles from the ground.

Barrel fatigue life, Utmattningstidslängd

This is the number of rounds a barrel can be fired with an acceptable risk of fatigue rupture. The barrel fatigue life is calculated using mechanical rupture methods based on crack propagation data for the material of the barrel. The calculation shall be made for a pressure level corresponding to an upper operational temperature for the ammunition, and an established safety factor for barrel life shall be applied.

Base bleed, base bleed device, Basflödesaggregat

An auxiliary device in a shell consisting of propellant in a combustion chamber. The propellant gases flow out into the wake behind the shell, providing equalization of pressure and thereby reducing drag.

Black powder, Svartkrut

Refer to the entry for 'Propellant'.

Blast pressure, *Ljudtryck*

Air shock waves created around the weapon as a result of firing. The shock waves normally emanate from the muzzle in recoil systems, and in recoilless systems from the aft end of the launcher as well as the muzzle.

Comment: Severe blast pressure may cause impairment of hearing. High levels may cause injury to the larynx. Extreme levels may even cause fatal injury (collapse of the lungs, etc.).

Booster, Auxiliary Booster, *Förstärkningsladdning*

A booster affixed to a main charge (e.g. by cementing, casting or screw attachment). The auxiliary booster consists of compressed high explosive designed to ensure initiation of the main charge.

Booster, Booster charge, *Detonator, Förstärkningsladdning*

A charge, usually comprised of pressed explosive, in an explosive train for amplifying the effect of the priming charge.

Comments: The booster is normally also used as a transfer charge between a fuze and other explosives in a shell. The booster charge may also be referred to in various contexts as booster, auxiliary booster or auxiliary charge.

Booster, Booster motor, *Booster*

A rocket motor that accelerates a vehicle in the launch phase, or amplification charge. Also see '*Detonator*'.

Bore safety, *Loppsäkerhet*

The property that enables ammunition and its constituent parts to withstand the environment during the bore phase of firing with the required level of safety.

Bridge primer, Bridge wire igniter, *Bryggtändare*

An electric initiator in which the initiation current passes through a wire or thin layer of metal that becomes heated, thereby initiating a priming composition or primary explosive.

Bullet impact safety, Bullet attack safety, *Beskjutningssäkerhet*

The capability of the ammunition to withstand bullet attack without initiating/ igniting.

Burst, *Brisad*

The explosion phenomenon of a detonating warhead and its corresponding practice ammunition. Compare '*Igniferous burst*'.

Cannon primer, *Tändpatron*

An igniting device in the form of a cartridge containing an initiator such as a percussion primer and booster charge. A cannon primer is mainly used in guns where the propellant is not kept in a cartridge case, such as in certain howitzers. A cannon primer is inserted (fed into) the breech mechanism. See also '*Artillery primer*'.

Cartridge case, *Patronhylsa*

A case, usually made of metal or plastic, incorporating an igniting device and containing propellant.

Comment: Cartridge cases are used in

- fixed rounds (permanently attached to the projectile),
- semi-fixed rounds (attached to the projectile, such as by a bayonet coupling, so as to be separable),)
- separated rounds (separated from the projectile but united before loading). Compare the entry for '*Separate case*'.

Case bonded charge, *Hylsbunden laddning*

Refer to the entry for '*Rocket propellant charge*'.

Circuit interrupter, *Kretssäkring*

Refer to the entry for '*Transmission safety device*'.

Combustion catalyst, *Förbränningskatalysator*

An additive in propellant and other propulsion agents designed to increase the rate of combustion.

Control system, Guidance system, *Styrssystem*

Functions and related subsystems that can change the path of a guided missile, torpedo or other guided munition.

Combustion chamber, *Brännkammare*

The space in which propellants burn, where applicable after mixing.

Compatibility, *Förenlighet*

A property of materials which means that they do not affect one another chemically when subjected to the specified environmental conditions.

Comment: TNT, for example, is affected by polyamides but not by olefin plastics. Polycarbonate plastic is embrittled by double-base propellant. Lead azide forms highly sensitive copper azide on contact with copper. Certain combinations of metals may cause galvanic corrosion that may involve a safety hazard.

Composite propellant, *Kompositkrut*

Refer to the entry for '*Propellant*'.

Cook-off, *Cook-off*

Inadvertent initiation of an explosive as a result of abnormal heating.

Comment: Cook-off can occur, for example, after a misfire in a hot barrel.

Danger Area, *Riskområde*

The area around a proving/firing site inside which there is a risk of injury.

Deactivate, *Desarmera*

A measure which leads to a permanent deactivation of the ignition system. Also see '*Disarm*', '*Neutralize*'

Deactivation of Ammunition, Demilitarization, *Avveckling av ammunition (isärtagning, destruktion, oskadliggörande)*

Disassembly of ammunition for an in-service surveillance inspection, for example, or to render components of ammunition harmless that can/will no longer be used (e.g. defective, exceeded the established service life, etc).

Deflagration, Deflagration

Deflagration is characterised by a combustion wave, sustained by the generation of heat in the decomposition zone, that spreads through the explosive or explosive mixture at sub-sonic velocity.

Comment: During normal use of propellants in rockets, barrels, gas generators, etc., the combustion rate (deflagration rate) – which is dependent on the pressure – is much lower than sonic velocity (in the magnitude of cm/s at 10 MPa). In the event of incorrect operation or malfunctions of various types, such as a blockage in the exhaust nozzle of a rocket engine or excessive charge density in guns, the combustion rate may increase uncontrollably so that the combustion chamber ruptures. This may even progress to detonation.

Delay, Delay device, Fördröjning

A device that provides the desired arming delay in a fuzing system. The delay may be achieved pyrotechnically, electrically, mechanically or chemically.

Design criteria and test plan, Materiel environmental specification, Materielmiljöspecifikation

The part of an item specification that contains requirements specifying resistance to environmental conditions and the environmental factor list for testing.

Destruction, Destruktion

See '*Demilitarisation of ammunition*'.

Detonation, Detonation

Detonation is characterised by a shock wave, sustained by a chemical reaction in the shock wave zone that propagates at supersonic velocity in the explosive.

Comment: Detonation gives maximum blast effect in explosives, and is normally started by a primary explosive which, even in small quantities, can transmit a sufficiently powerful shock wave impulse to initiate a detonation process.

Detonator, Sprängkapsel

An initiator that is initiated by a stab, percussion, friction, flame or break sensitive primary explosive designed to initiate the detonation in an explosive.

Disarm, Neutralize, Render safe, Återsäkra

To restore weapons or ammunition to its original, safe position.

Example: Reassembly of transport safety device.

Dynamic analysis, Dynamisk analys

Verification through testing of the flow in a computer program to discover how the program behaves in different situations.

The following items *inter alia* are of particular interest:

- determination of which segments of the program are executed most frequently,
- time studies for certain operations,
- tracing of variable values,
- inspection of invariant conditions,
- code that is not executed,
- inspection to verify that the test comprises all elements of the program.

Dynamic interaction, Dynamisk interaktion

The interaction between projectile/shell and barrel during the launch process.

Comment: Incorrect interaction can cause damage to the bore and/or greater dispersion and/or ammunition malfunction (e.g. failure to initiate).

Electric detonator, Elsprängkapsel

An initiator that is electrically initiated and which contains primary explosive for a detonating explosive train.

Electric gap detonator, Spalttändare

An electric initiator that is very fast and easily initiated.

There are three main types of gap detonator:

- electrically conducting composition, consisting of primary explosive and graphite or metallic powder,
- graphite bridge, in contact with primary explosive,
- spark gap, adjacent to primary explosive.

Thus there is no hot wire, and the initiating function in all three types is based on energy concentration in hot spots.

Electric igniter, *Eltändare*

See ‘*Electro Explosive Device, EED*’

Electric primer, *Elkrutpatron, eltändskruv*

An initiator that is initiated electrically, containing ignition unit and booster charge, all enclosed in a case/casing.

Electric primerdetonator, *Elsprängrör*

An electric initiator unit for depth charges, naval mines, torpedoes, explosive cutters and detonators. Compare ‘*Electric detonator*’

Electro Explosive Device, EED

A priming device that is initiated electrically. Electric igniters and initiators, electric primers, electric artillery primers, electric detonators, electric blasting caps and electric priming detonators are examples of EEDs.

Electromagnetic pulse, EMP, *EMP*

An electromagnetic pulse is a burst of electromagnetic energy. It may occur in the form of a radiated electric or magnetic pulse depending on the source. EMP is generally damaging to electronic equipment, and its management is an important branch of electromagnetic compatibility (EMC) engineering. May occur when a nuclear charge detonates (NEMP). A lightning generates a so-called LEMP. A high-power microwave can generate an EMP.

Environment/Operational environment, *Miljö*

The cumulative effect of all the natural and induced environmental factors to which an item is subjected at a specific moment.

Environmental factor, *Miljöfaktor*

A factor related to the surrounding environment (e.g. mechanical, electrical, chemical, climatic, or biological) that can affect ammunition so that safety is lowered, a fault occurs, ageing is accelerated or similar. Environmental factors can usually be separated during testing.

Environmental force, Environmental conditions, *Miljövillkor*

The characteristics of the operational environment which can be used as criteria for arming conditions and/or initiation.

Environmental severity, *Miljöstränghet*

The value of the physical and chemical magnitudes that is characterised by the environment or an environmental factor.

Erosion, *Erosion*

The removal of material from a surface by the action of another medium flowing over the surface.

Exhaust nozzle, *Dysa*

That part of a reaction engine through which the combustion gases of the propulsion agent escape at high velocity. An exhaust nozzle consists of an inlet, a constricting section, and in most cases an expansion section. The thermal energy released is converted into kinetic energy in the exhaust nozzle.

Explosive, *Explosivämne*

Explosives are defined in the The Act on Flammable and Explosive Goods as solid or liquid substances or mixtures thereof that can undergo a rapid chemical reaction whereby energy is released in the form of pressure-volume work or heat.

Explosive articles, *Explosiv vara*

Articles containing an explosive substance. Pyrotechnic parts intended for gas generation in other applications other than pure weapons applications (for example, airbags, fire extinguishers) are also included in the concept of explosive articles.

Exploding Bridge Wire Igniter, EWB, *EBW-tändare*

An electric initiator without priming composition or primary explosive. Initiation is achieved by an exploding wire in contact with a low-density explosive, usually PETN.

Comment: The wire is made to “explode” by a very high power input (MW).

Exploding Foil Initiator, *EFI-tändare*

An electric initiator without priming composition or primary explosive. Initiation is achieved by an exploding metal foil accelerating a plastic disc against the high density explosive.

Comment: The metal foil is made to “explodes” by very high power input (MW). The term “Slapper” is also used for EFIs.

Explosive plunger, *Sprängkolv*

Explosive charge included in, for example, an explosive cutter.

Explosive train, Tändkedja

A combination of various elements (explosives, channels, etc.) designed to initiate a charge. The explosive train may contain conditional interrupters or barrier locks (safety devices).

Extreme service environment, Abnorm miljö

Environmental factors of such a severity that arise in conjunction with accidents or enemy attack (e.g. fire, bullet attack).

Flame safety device, Flamsäkring

An interrupter in an explosive train that prevents the transmission of ignition to a deflagrating main charge. Compare the entry for ‘*Transmission safety device*’.

Fuel, Bränsle

The propulsion agent that is combusted (oxidated) to generate energy.

Fuel Air Explosive, FAE

A warhead based on fuel that is dispersed in the air in an appropriate ratio prior to initiation.

Full form gauging, Schamplunering

An inspection method for the loadability of ammunition.

Fuze, Tändrör

A fuze is a type of initiation system in which the sensors, safety system, initiator and booster are integrated into the same assembly unit – generally for artillery ammunition.

Comment: Fuzes are classified according to:

- mode of initiation, e.g. impact, time or proximity,
- location, e.g. in nose, mid-section or base,
- sensitivity, e.g. sensitive or super sensitive,
- time of action, e.g. instantaneous or delay,
- safety devices in fuzes categories,
- interface dimensions of the fuzing system.

Fuze magazine, Bottenladdning

Reinforcement charge in fuzes usually consisting of extruded explosive. See ‘*Booster, Booster Charge*’.

Fuzing system, *Tändsystem*

A generic term for a device designed to initiate charges in ammunition at a specific time or location.

Comment: A fuzing system also contains a safety system that shall prevent inadvertent initiation that can cause injury or damage to equipment or serious malfunctions. A fuzing system consists of (a) sensor(s), a safety system (often referred to as a SAD/SAU) and a priming device.

The safety system contains interrupters and barrier locks controlled by arming conditions.

There are two different principles for the design of a fuzing system:

- a. an out-of-line explosive train in which the SAD/SAU contains a mechanical interrupter which, in safe mode, prevents transmission in the explosive train,
- b. an in-line explosive train not having an interrupter. In this case the safety and arming functions are allocated to the electric circuits controlling the initiator in the explosive train.

The explosive train contains no primary explosive.

In out-of-line systems the interrupter often incorporates a detonator or primer which, when in safe mode, is physically located in such a way that its detonation or deflagration cannot be transmitted to subsequent charges. This arrangement is the reason for the term ‘out-of-line’.

The interrupter may consist of a rotor, slide or equivalent.

Fuzing systems are often named according to the method of functioning of their sensor(s), such as impact or proximity sensing, or delay systems.

Gas generator, *Gasgenerator*

A device for producing a gas flow under pressure by combustion of a propellant.

Comment: There are two types of gas generators: solid and liquid propellant gas generators.

Guided missile, *Robot*

An unmanned object that is launched or dropped/released, and which is designed to move in a flight path totally or partially above the earth surface guided by external signals or by integrated devices.

Handling, Hantering

In the Act on Flammable and Explosive Goods handling denotes all handling from manufacture to final use and destruction. This comprises *inter alia* storage, transport, handling, use, and disposal.

Hardware, Maskinvara, hårdvara

A collective term for a computer system's physical parts.

Hazard, Riskkälla

Something that may lead to personal injury or damage to property, or the external environment. See also the *Armed Forces' System Safety Handbook*.

Comment: In English the word “hazard” often has a wider meaning, also comprising a dimension of likelihood.

Hazard arming, Vådaarmering

Inadvertent arming within the safety distance/time.

Hazard initiation, Vådatändning

Inadvertent initiation of a propelling charge or warhead.

Hazardous event, Undesirable event, Vådahändelse

An event that occurred inadvertently, that is, without intention, unplanned and which may result in an accident or incident.

High explosive, Sprängämne

An explosive whose decomposition normally occurs through detonation.

Comment: To start a detonation in a high explosive usually requires initiation with high energy and shock wave effect provided by, for example, a primary explosive.

High Power Microwaves, HPM, HPM

High-energy pulsed microwave radiation.

Hybrid rocket engine (motor), Hybridraketmotor

Refer to the entry for ‘Rocket motor’.

Hypergolic propulsion agent combination, Hypergolisk drivämneskombination

A combination of propulsion agents (fuel – oxidiser) that react spontaneously with one another.

Ignite, Antända

To make an explosive deflagrate.

Igniferous burst, Krevad

The explosion phenomenon of a deflagrating warhead. Compare the entry for 'Burst'.

Impulse (rocket) motor, Impuls (raket) motor

A motor of very short burning duration used to provide guidance impulses etc.

Independent safety device, Oberoende säkring

A safety device is independent if its status is not affected by the status of any other safety device in the system.

Inert, Inert

Not chemically reactive.

Inherent safety, Egensäkerhet

The safety property of a torpedo and its constituent parts that enables it to make contact with the seabed, or to somersault, or collide with objects in the water, without detonation of the main charge within the safe separation distance.

In-flight safety, Bansäkerhet

The property of ammunition and parts thereof not to detonate or burst in trajectory from the point at which the fuzing system is armed until the point at which it is designed to function.

In-Line System, Obruten tändkedja

An explosive train without interrupter, i.e. if one element in the explosive train is initiated then the booster in the fuzing system will also be initiated.

Initiate, Initiera, Tända

To initiate an explosive, to bring an explosive to detonation.

Initiating device, Tändanordning

Device intended for ignition of deflagrating or detonating explosive charges containing both ignition device (mechanical or electrical) and booster charge. A priming device may in its simplest form consist of only the ignition unit, such as a primer in small-calibre ammunition.

Initiator, Tändenhet

A device, such as a primer or detonator, that receives initiation signal(s) and subsequently initiates an explosive train. Examples of initiators are primers and detonators. See ‘*Priming device*’.

Insensitive munition, IM, IM

Ammunition with a lower sensitivity than current “normal” ammunition. This is achieved by using a lower sensitivity propellant and explosive, or by encasing the propellant in such a way that its sensitivity is reduced.

Integrated fuze system (or initiator), Integrerat tändsystem (eller tändenhet)

An ignition system that is integrated into a munition in such a way that it cannot be removed completely or in part.

Intelligent ammunition, Intelligent ammunition

Ammunition with built-in logic, target seeker, target sensor or similar to increase the probability of hitting the target.

Interrupter, Avbrytare

A mechanical component that causes an intended interruption in an explosive train. It may consist of a rotor, slide, or similar device.

Interrupted explosive train (Out-of-line explosive train), Bruten tändkedja

A mechanical component that causes an intended interruption in an explosive train. It may consist of a rotor, slide, or similar device.

Item, Specimen, Objekt

Any piece of defence materiel or software being dealt with at a specific moment. An item may, for example, be a complete guided missile, an electronic component or a computer program. Compare the entry for ‘*Test item or test specimen*’.

Launch phase, Utskjutningsfas

The period from when the ammunition has irrevocably started to move in the launcher until it has left the launcher.

Liner, *Liner*

A binding layer between the propelling charge and the cartridge case, usually consisting of the same material as the fuel polymer in the propellant.

Loading safety, *Laddssäkerhet*

The property of ammunition and its constituent parts that enables it to be loaded into a weapon with the required level of safety.

Low Vulnerability Ammunition, LOVA, *LOVA*

Propellant for which action has been taken to reduce sensitivity to initiation due to fire or the impact of extreme environments.

Comment: See STANAG 4439.

Main charge, *Huvudladdning*

The largest charge in a high explosive warhead or propulsion device.

Mask safety, *Masksäkerhet*

The property of ammunition and its constituent parts that enable firing through vegetation (mask) close to the weapon without a burst or igniferous burst resulting.

Maximum Operating Pressure (MOP), *Maximalt operativa tryck (MOP)*

The pressure that a specific charge provides under the most extreme conditions, such as in terms of propellant temperature, and which statistically must not be exceeded by more than 13 cases out of 10,000.

Mission profile, *Uppdragsprofil*

A part of the operational profile that defines conditions to which an item can be subjected when used in a specific way, such as an airborne missile suspended from an aircraft and carried on a mission, which in turn is defined in the form of flight velocities, altitudes and durations. Compare the entry for '*Operational profile*'.

Mishap, Accident, *Olycka*

An undesired event or series of events which cause unacceptable injury to a person, damage to property or damage to the external environment.

Mono propellant, Enkomponentdrivämne

A propellant that decomposes in a reaction chamber to form propellant gas. Decomposition can be by catalysis or be started by the application of heat.

Multiple warhead, Multipelstridsdel

A warhead which in turn consists of several warheads, submunitions.

Munition

In this handbook synonymous with ammunition.

Comment: In Swedish, there is no distinction between Ammunition and Munition

Muzzle safety, Mynningssäkerhet

The property of the ammunition and its constituent parts that enables it to pass through a fixed obstacle close to the muzzle of the weapon with the required level of safety.

Neutralize, Render safe, Säkra

To activate latch or barriers, in ammunition or weapons, to prevent firing. Also see disarm and neutralization.

Neutralization, Neutralisering

Prevention of an armed fuzing system from being initiated, for example by discharging ignition capacitors or by interrupters returning to unarmed state.

Obturator, Obturator

In some weapons, a sealing ring (obturator) may be used on a projectile in order to obtain a satisfactory seal during the barrel (launch) phase.

Operational profile, Driftprofil

The part of the life cycle comprising use of the product. The operational profile is defined in terms of various methods of application and their respective durations.

Oxidiser, Oxidator

Oxygen generator that oxidize fuel during energy conversion.

Pendulum pressure, Pressure oscillation, *Pendeltryck*

Pressure perturbation in barrels and rocket engines.

Barrels: Pressure oscillations that can occur in long chambers not completely filled by the propelling charge. Pressure in the chamber may thus increase locally to such an extent that deformation occurs.

Rocket engines: Pressure oscillations that can occur in solid propellant as well as liquid-fuel rocket engines as a result of resonance between acoustic perturbation and pressure-dependent combustion. The geometry of the engine and the charge, together with other factors, contribute to this. The pressure oscillations may be of such an amplitude that engine ruptures.

Plastic-Bonded Explosive, PBX, *PBX*

Plastic-bonded explosive substance.

Polymer, *Polymer*

A chemical compound formed by the interlinking of small units to large molecules. Polymers can be subdivided into plastics (such as polyethylene, PVC and phenolic plastics) and elastomers or rubber materials (such as natural rubber, polybutadiene rubber and styrene-butadiene rubber).

Premature burst, *Banbrisad*

A burst that occurs inadvertently in the trajectory before the designated point or time.

Priming composition, *Tändsats*

A pyrotechnic composition that is initiated by heat (friction, percussion, flame, spark, hot wire).

Priming device, *Tändmedel*

A device containing an initiator (mechanical or electrical) and a booster whose purpose is to initiate or ignite an explosive charge.

Primary Explosive, *Tändämne, Primärsprängämne*

An explosive that decomposes through detonation and which requires little initiation energy, for example in the form of heat (friction, percussion, flame or hot wire), and is used to initiate detonation in high explosives (such as TNT). A primary explosive detonates even in very small quantities when there is little or no confinement.

Primer, Tändbatt

An initiator consisting of a case (capsule) containing a stab, percussion, flame or other heat sensitive priming composition designed to initiate deflagration in an explosive train.

Priming detonator, Sprängrör

An initiator for depth charges, underwater mines, torpedoes and explosive cutters. Compare the entry for 'Detonator'.

Procurement of off-the-shelf materiel, Anskaffningsprogram för färdig materiel

Guidelines relating to system safety shall be applied when acquiring OTS materiel systems.

Projectile, Projektil

- General: A body projected (launched) by an external force and which subsequently continues in motion under its own inertia.
- Applied to ammunition: A warhead without an integral propelling force, and which does not contain explosives with the exception of illuminating compositions in tracers and incendiary substances in small incendiary compositions (spotting charges), fired from tube-launched weapons.

Comment: The term projectile is also used as a generic name for all types of warheads in tube-launched ammunition.

Propellant, Krut

An explosive which on initiation forms a gas. This gas is used for example to expel a bullet or projectile from a weapon or provide propulsion to a rocket or guided missile. A propellant normally decays as a result of so-called deflagration, a combustion that takes place far below the speed of sound, usually at 10-100 mm/s. Propellants are usually divided up into the following types: nitrocellulose based (single base, double-base, triple-base propellants) and composite propellants (mechanically mixed propellants).

Propulsion agent, Drivämne

Substance which acts as a fuel and / or oxidizing agent, and which contains the energy required for propulsion. Fuels can be solid, liquid or gaseous, mixed with each other as in gunpowder or separated as in liquid rocket motors and air consuming motors. See also 'Propellant'.

Propulsion cartridge, *Drivpatron*

A cartridge containing a propelling charge and igniting device, used for example in mortar ammunition and rifles.

Propulsion device, *Drivanordning, drivdel*

The part of the ammunition that provides the necessary impulse to transport the warhead to the target.

Pyrotechnic composition, *Pyroteknisk sats*

An explosive that consists of a mixture of fuel and oxidiser, usually in solid form, which are not normally themselves explosives.

The components can react with each other in the form of deflagration involving heat generation.

Pyrotechnic compositions are usually used for:

- functions in explosive trains in the form of ignition, delay, initiation,
- effect in warheads in the form of light, fire, smoke, noise.

Pyrotechnics for Technical Purposes, *Funktionspyroteknik*

Pyrotechnic components intended to generate power or heat in for example “cable cutters”, starting cartridges, activators for fire extinguishers and pressure vessels.

Permissible Individual Maximum Pressure, Gun-PMP), *Pjäs-PMP*

The pressure which, for reasons of safety, must not be exceeded at any point in the weapon by more than 13 rounds in every 10,000, statistically.

Pyrolysis, *Pyrolys*

The decomposition of solid or liquid substances caused by the effect of heat into smaller, usually gaseous, molecules.

Reaction chamber, *Reaktionskammare*

A chamber into which liquid or gaseous propellants are injected and made to react in order to generate propelling gas.

Reaction motor, Jet engine, *Reaktionsmotor*

A motor in which the thrust is generated by the momentum of an escaping working medium (combustion gases, reaction products, air, etc).

Recoil, *Rekyl*

Recoil is the phenomenon that occurs when a weapon reacts to the effect of the propellant gases and acceleration of the projectile. There are different ways of measuring recoil such as impulse, force and energy.

Relaxation to rupture, *Relaxation till brott*

The delayed forming of cracks in a deformed material.

Requirements, *Krav*

Shall requirements (*Skall*). These requirements are crucial and mandatory for achieving the required safety of a system.

Should requirements (*Bör*). These requirements are important for the safety of the system and should therefore be considered where possible.

Requirement specification, *Kravspecifikation*

A specification issued by the purchaser to provide a basis for request for tender prior to procurement, or issued as a requirement document when placing an order.

Resistance to environmental conditions, *Miljötolighet*

An object's ability to withstand certain severities over a period of time.

Rheological properties, *Reologiska egenskaper*

The deformation properties of a material subjected to external forces. In viscoelastic materials the properties are time-dependent.

Risk, *Risk*

See *Accident risk*. See also the *Armed Forces' System Safety Handbook*.

Rocket, *Raket*

An unmanned, unguided self-propelled object incorporating a warhead and rocket motor or engine.

Rocket Assisted Projectile (RAP), *Reatil*

A shell with a (propellant) rocket engine that provides thrust in flight, thereby increasing range.

Rocket engine, Rocket motor, *Raketmotor*

A type of reaction motor that carries its own fuel and oxidiser, and is thus independent of the surrounding atmosphere for combustion.

There are three types of rocket engines/motors:

- solid propellant rocket motor,
- hybrid rocket motors. The propellant consist both of a solid and a liquid propellant,
- liquid fuel rocket motors. The propellants are liquid – mono-propellant or bi-propellant – in the latter case an oxidiser and fuel. Tri-propellant may also be used.

Rocket motor igniter, *Raketmotortändare*

An igniting device for a rocket motor.

Rocket propellant charge, *Raketkrutladdning*

A solid propellant rocket motors. The propellant charge is determined inter alia by the type of propellant, charge geometry, and the method of fixing it inside the rocket casing. An unbonded charge is free from the rocket casing but is supported against it or against special support. A case bonded charge is wholly or partially bonded to the rocket casing by means of an intermediate layer (liner). The charge may also be bonded to an internal support tube.

Safe separation distance, *Säkerhetssträcka (-distans)*

The minimum distance between the launcher (or drop/release device) and the ammunition beyond which a burst is judged to give an acceptable level of safety for personnel and equipment located at the launcher or drop/release device. Reasonable evasive action by the weapon platform is assumed.

Safety analysis, *Säkerhetsanalys*

A collective term for those parts of the system safety activities involving both systematic identification of possible hazardous events and their causes and qualitative or quantitative assessment of the achieved level of safety.

Safety assessment of existing materiel, Översynsprogram för befintlig materiel

Programs with regard to system safety to be applied in the review of existing systems which have not previously been examined with regard to modern system safety requirements.

Safety, Arming and Ignition-unit, SAI-unit, Säkrings-, armerings- och tändenhet, SAT-enhet

Safety and Arming unit, SA-unit with an ignition function.

Safety and Arming Device, SA Device, Safety and Arming Unit, SAU, SA-enhet (Säkrings- och armeringsenhet)

A device that arms a fuzing system at the correct time, and which also prevents inadvertent initiation of the explosive train.

Safety device, Sprängkapselsäkring

A detail or combination of details to prevent inadvertent initiation of a main charge in ammunition.

Also refer to the entry for ‘Transmission safety device’.

Safety distance, Säkringsavstånd

The distance from the launcher (drop/release device) to the point in the trajectory or flight path at which a safety device is released.

Comment: Each individual safety device has its safety distance.

Safety feature, Spärr

A device that locks a transmission safety device. A mechanical component that locks the interrupter in unarmed or armed mode or a component/function that breaks an electric circuit.

Safety system, Säkringssystem

The generic term used to denote the combination of all the safety devices in a fuzing system. The safety system contains interrupters and other safety features that are controlled by arming conditions.

Sealing Ring, Tättningsring

See ‘Obturator’.

Secondary armament, *Sekundärbevärning*

This term refers to additional weaponry that can be mounted on a combat vehicle to provide secondary or supporting functions. The following types of weapon are considered to belong to this category:

- machine gun or cannon for covering fire,
- parallel machine gun for use together with the main armament,
- mortars,
- flare launchers.

Secondary charge, *Sekundärladdning*

Refer to the entry for ‘*Booster charge*’.

Self-destruction, *Autodestruktion*

Automatic initiation of the warhead of a munition that has missed the target, for example, or was not initiated within the designated time after arming.

Sensor, *Sensor*

The part of a fuzing system that detects e.g. the arming and initiating conditions.

Separate case, *Laddningshylsa*

A case, normally made of metal (e.g. brass) with an igniting device and containing a propelling charge. It is kept separate from the projectile during transport and loading.

Comment: A separate case requires two operations when loading the weapon. Compare the entry for ‘*Cartridge case*’.

Service life, technical life, *Teknisk livslängd*

The period during which the ammunition can be transported and stored in the prescribed packaging under the specified storage conditions without changes occurring that can result in hazardous events or an unacceptable degradation of performance.

Shall requirements, *Skallkrav*

These are requirements that are of decisive significance to the achievement of the necessary safety level in a system. See also to the entry for ‘*Requirements*’.

Shelf life testing, *Livslängdsprovning*

Testing to verify the performance, reliability, and safety of a product after simulated depot storage.

Shell, grenade, *Granat*

A projectile with a cavity filled with explosive, smoke or illuminating composition, submunitions or equivalent.

Should requirement, *Börkrav*

Non mandatory but desired requirement. See also to the entry for 'Requirements'.

Similar to operational conditions, *Typlik*

Realization of hardware, software (in cooperating functional parts outside the tested software) or environment that is as close to the final design or environment as possible in terms of function and behavior.

Example: If the requirement is that software must be verified with a typical power supply, the power supply of the series design must be used.

Squib, *Tändpiller, tändpärla*

An initiator that is initiated electrically and which comprises electricity supply leads with a heating hot wire, between them surrounded by priming composition.

ST-Fuze, *ST-stubin*

A shock-tube fuze (ST fuze) consists of a plastic tube coated on the inside with a thin layer of high explosive or filled with a combustible gas mixture.

The initiation impulse is transmitted through the tube as a shock wave.

Stability, *Stabilitet*

The property that enables a material not to change in the environment in which it exists.

Stabilizer, *Stabiliseringsmedel*

An additive in propellant and other propulsion agents designed to keep decomposition at a low level and thereby ensure storage capability.

Sterilization, *Sterilisering*

The prevention of an armed fuzing system from being initiated by permanently damaging some part of the safety system. (Compare the entries for 'Neutralization' and 'Deactivate'.)

Storage, logistical, *Förvaring, logistisk*

The long-term storage of items in depots, usually under controlled humidity conditions.

Storage, tactical, *Förvaring, taktisk*

The storage of an item for a limited period of time under field conditions. It denotes storage in ammunition depots or at readying sites located adjacent to bases, naval vessels, or deployment areas, usually without any kind of controlled environment.

Sub-calibre barrel, *Instickspipa, Tubkanon*

A small-calibre barrel inserted inside a standard barrel, and used either for aligning the standard barrel or for practice firing. Also known as sub-calibre adapter.

Surveillance inspection, *Säkerhetsteknisk kontroll*

An activity designed to establish whether the status of ammunition has changed so as to jeopardise safety during storage, transport, operation or other handling.

Sustainer, Sustainer motor, *Banfasmotor*

A motor designed to provide thrust during flight.

System Safety, *Systemsäkerhet*

The property of a technical system not inadvertently causing damage to a person, property or external environment. See also the Armed Forces' *Handbook on System Safety*.

Technical life, *Teknisk livslängd*

The time ammunition can be transported and stored in the prescribed packaging under prescribed storage conditions (temperature, humidity) without such changes occurring that can lead to hazardous events or unacceptable changes in performance.

Terminal guidance device, *Styrverk*

A shell that is corrected in the final path of its trajectory by intermittent lateral forces triggered by guidance signals.

Terminally corrected projectile, *Slutfaskorrigerad granat*
A shell that is corrected in the final path of its trajectory by intermittent lateral forces triggered by guidance signals.

Terminally guided projectile, *Slutfasstyrd granat*
A shell that is guided in the final part of its trajectory by continuous lateral forces controlled by guidance signals.

Test, *Provning*
An investigation to determine one or more properties of an item/specimen.

Test item, Test specimen, *Prov*
An object, such as a component or subsystem, that is to be tested.

Transmission safety device, *Överföringssäkring*
An interrupter in an explosive train including associated safety components. Synonyms for this concept are detonator safety device, arming device, and flame safety device (out-of-line explosive train).
A switch in the electric circuit(s) of a fuzing system including associated safety components. Also known as a circuit breaker (in-line explosive train).

Transport, Logistical, *Transport, logistisk*
Transport of items to and between storage depots, and from storage depots to and from maintenance workshops.

Transport safety, *Transportsäkerhet*
The property that enables transport, handling and storage with the required level of safety.

Transport, Tactical, *Transport, taktisk*
Transport of items in field conditions from depot storage to bases, naval vessels, deployment areas, etc. The concept includes short transport of items within and between these sites.

The UN test manual, *FN:s testhandbok*
In this book a used short form for UN Recommendations on the Transport of Dangerous Goods, Manual of Test and Criteria.

Unbonded charge, *Friliggande laddning*

Refer to the entry for 'Rocket propellant charge'.

Unexploded ordnance, UXO, *Oexploderad ammunition (OXA)*

Munitions whose expected function failed to materialise (dud).

Unguided weapon, *Ostyrt vapen*

A weapon whose ammunition (projectiles, rockets, etc.) is only controlled by directing the weapon at launch.

Validation, *Validering*

A method of verifying that requirements are correct, i.e. that the product functions as intended in its operational environment.

Verification, *Verifiering*

Confirmation by presenting evidence that specified requirements have been fulfilled. This can be achieved by inspection, review, analysis, test or comparison.

Wad, *Deckel*

A flat or cupped unit, often made of cardboard, that is inserted into a cartridge case to secure the propelling charge in position and to reduce the risk of cook-off.

Wake, *Vak*

The volume immediately behind a projectile in motion. Compare the entry for 'Base bleed'.

Warhead, *Verkansdel*

The part of ammunition which at a predetermined time or place provides the intended effect by means of pressure, fragmentation, or incendiary effect, or any combination of these effects; other forms may be smoke or illuminating effects or sensor jamming.

Weapon, *Vapen*

A device for firing, launching, dropping or deploying ammunition.

Weapon safety, *Vapensäkerhet*

The property of a weapon that enables the weapon under specified conditions to be transported, kept in depot storage, used, maintained and demilitarized without any hazardous event occurring, or any constituent parts of the weapon being affected in such a way that a hazardous event could occur.

Wear (in barrel), *Slitage, slitning*

The mechanical, thermal, and chemical influences on the internal surface of the barrel. There are two wear effects: barrel wear through the mechanical effect of the round, and erosion of the barrel caused by the mechanical and chemical influences of hot, fast flowing propellant gases. As a rule, the beginning of rifling is most exposed to wear.

Worn barrel, *Slitet eldrör*

A worn barrel has less than 25% of its total barrel life left. The wear life is usually established with reference to decreased muzzle velocity (V_0), dispersion, and wear at the beginning of the rifling.

Comment: A worn barrel is a prerequisite for some compatibility tests.

Appendix 2 Key to abbreviations

AD	Autodestruction
AFS	The Swedish Work Environment Authority's code of statutes
ASIC	Application Specific Integrated Circuits
AUR	All up Round
CBRN	Chemical, biological, radiological and nuclear
CE	EES Mark of Conformity
CLP	Classification, Labelling and Packaging
COTS	Commercial-off-the-Shelf
CPLD	Complex Programmable Logic Device
EED	Electro Explosive Device
EEPROM	Electrically Erasable Programmable Read Only Memory
EFI	Exploding Foil Initiator
EMP	Electro Magnetic Pulse
EOD	Explosive Ordnance Disposal
EPROM	Erasable Programmable Read Only Memory
ESD	Electro Static Discharge
F-code	Storage code for ammunition and other explosive goods
FAE	Fuel Air Explosives
FM	Swedish Armed Forces
FMEA	Failure Mode and Effect Analysis
FMECA	Failure Mode and Effect Criticality Analysis
FMV	Swedish Defence Materiel Administration

Appendix 2 Key to abbreviations

FOA	Former name of Swedish Defence Research Agency, FOI (before merger with FFA)
FOI	Swedish Defence Research Agency
FPGA	Field Programmable Gate Array
FSD	Swedish Defence standard
HF	High frequency
HKV	Headquarters (of the Armed Forces)
HP	Hydrogen peroxide
HPT	High Test Peroxide
HPM	High Power Microwave
IEC	International Electrotechnical Commission
IFTTEX	Instruction governing storage and transport of Swedish Armed Forces' explosive goods
IM	Insensitive Munition
IR	Infrared
ISP	In System Programming
LEMP	Lightning Electro Magnetic Pulse
LOVA	Low Vulnerability Ammunition
MEOP	Maximum Expected Operating Pressure
MIL-STD	Military Standard, USA
MOP	Maximum Operating Pressure
MOTS	Military off the Shelf
MOU	Memorandum of Understanding
MSB	Swedish Civil Contingencies Agency
NBC	This term has been replaced by CBRN
NEMP	Nuclear Electro Magnetic Pulse
OTP	One Time Programmable

PBX	Plastic-Bonded Explosives
PHA	Preliminary Hazard Analysis
PHL	Preliminary Hazard List
PHS&T	Packaging, Handling, Storing and Transport Regulations
PLD	Programmable Logic Devices
PMP	Permissible Individual Maximum Pressure
PTTEM	Preliminary Tactical Technical Financial Objectives (has been replaced by SMS)
RAM	Random Access Memory
REACH	Registration, Evaluation, Authorisation and Restriction of Chemicals
RFP	Request for Proposal
Rg	Advisory group (at FMV)
RMS	Swedish Rules for Naval Safety
ROA	Aiming and firing limitation or Laying and firing limitation
RoHS	Restriction of the use of certain Hazardous Substances in electrical and electronic equipment
ROM	Read-only Memory
RSV	Shaped charge
SACLOS	Semi Automatic Command to Line of Sight
SAD	Safety and Arming Device
SAI	Safety, Arming and Ignition unit
SEU	Single Event Upsets
SFRJ	Solid Fuel Ramjet
SFS	Swedish Code of Statutes

Appendix 2 Key to abbreviations

SMS	Operational Requirements
SRAM	Static Random Access Memory
SRP	Safety Requirement Proposed
SS	Safety Statement
SSPP	System Safety Program Plan
SäkI	Safety Instructions for the Swedish Armed Forces, has been replaced by SäkR
SäkR	Safety Regulations for the Swedish Armed Forces
THA	Threat Hazard Analysis
TTEM	Tactical Technical Financial Objectives, is replaced by SMS
UAV	Unmanned Aerial Vehicle
UN	United Nations
UXO	Unexploded ordnance
WDT	Watch Dog Timer
VDV	Vibration Dose Value

Appendix 3 Standards

Over a number of years from the mid-1970s, a large number of Swedish defence standards (FSD) were developed regarding ammunition safety. Many of these were translations and adaptations of primarily British, American and NATO standards. Since Sweden joined the European Union (EU), the Swedish rules for the use of standards in procurement have been adapted to the EU regulations. Here, however, it is stated that civilian international, European and national standards have not been developed to the required extent in the area, which is why, in many cases, reference is still made to international defense standards.

FMV's use of standards in connection with procurement is regulated in the Public Procurement Act (LOU), in the Act on Procurement in the Defense and Security Area (LUFS), in the Act on Procurement in the Utilities Sectors and in the Act on procurement of concessions.

FMV is constantly developing and improving the forms for how national and international standards such as primarily civilian and military standards are to be used. In collaboration with the Armed Forces, the choice of standards is focused on accordance with applicable laws and regulations as well as agreements the Armed Forces has within the framework of international collaborations.

Design managers within FMV make design decisions that instruct and regulate which standards are to be used and how they in turn are to be applied. Design decisions are described in design rules and rules of action.

When starting system work/projects that include the use of the standards, it must always be examined whether there are current design rules that are relevant to the activities to be carried out.

The Swedish Armed Forces' strategic focus states that the Swedish Armed Forces must improve the conditions for Sweden to be able to provide and receive military support that can be both indirect and direct. In this context, the work on the host country support agreement with NATO is of great importance, especially with regard to the use of common standards and methods.

The use of standards in the field of ammunition is also affected by NATO-agreed partnership goals within the framework of the Partnership for Peace Planning and Review Process (PARP). NATO directs the use of standards that partner countries have to implement in collaboration with NATO units.

Current national laws and regulations on procurement leave room to use, for example, NATO standards as these are a prerequisite for agreed coordination of international procurement in the field of ammunition and as they are the starting point for interoperability in international operations.

Within the Armed Forces and FMV, there has been a focus for several years stating that when choosing standards, the aim should be to minimize the use of national defense standards and these should only be developed in exceptional cases.

Thus it can be stated that the standards that mainly have been used nationally in the field of ammunition safety mostly are NATO standards as well as defense standards from the USA (MIL-STD) and the United Kingdom (DEF-STAN).

EU/EDA standardization work in this area

Within the EU, work is underway to harmonize the regulations for the qualification of ammunition. As the majority of EU members also are members of NATO, the existing work carried out by NATO is largely used. The work is coordinated within the working group European Network of National Authorities on Ammunition (ENNSA). EDA standardization work is reported in the European Defense Standards Reference System (EDSTAR). The EDSTAR website presents current lists of standards and reports in the area and reports in the area that are considered Best Practice and which are therefore recommended for use.

NATO's standardization work in this area

One of the foundations for NATO's standardization work is that the actual standard is published in a document, for example in an “Allied Ordinance Publication (AOP)” or “Safety and suitability for service assessment (AAS3P)”. The agreement to apply the standard is then taken in a “Standardization Agreement (STANAG) attached to the documents. See for example AOP-15 where the use is regulated in STANAG 4297.

Within NATO, the AC 236 working group is responsible for the work on the standardization of the munitions safety area.

At the top of the structure of ammunition safety standards in NATO is STANAG 4297 with the underlying AOP-15 (Guidance on the Assessment of the Safety and Suitability for Service of Non-nuclear Munitions for NATO Armed Forces).

Somewhat simplified, AOP 15 has the purpose of:

- Provide a common basis for the assessment of safety and suitability for the deployment of ammunition in NATO's armed forces.
- Recommend safety-related design and development requirements for ammunition systems including subsystems and components.
- Present a method for identifying and reducing risks associated with ammunition and methods for presenting the results in order to show that the risks are acceptable.

The standard contains four appendices which together give a good description of the scope of the standard.

Within AC 326 SG B, a major work is being done, which is expected to take several years, with restructuring and developing the standards for qualification of different types of ammunition. New standards that have been developed are:

- STANAG 4629 AAS3P-01 - Allied Ammunition Safety and Suitability for Service Assessment Testing Publication – Guidance.
- STANAG 4757 AAS3P-10 (Safety and Suitability for Service (S3) Assessment Testing for Shoulder Launched Munitions).

Appendix 3 Standards

- Appendix A, Questionnaire to identify the environments in the ammunition life cycle.
- Appendix B, List of STANAGs that provide guidance in the area.
- Appendix C, Guide and examples of information packages that can form the basis for an assessment of the ammunition's safety and suitability for the introduction of ammunition.
- Appendix D, Guide and examples of a numerical risk analysis.
- STANAG 4758 AAS3P-11 (Safety and Suitability for Service Assessment Testing for Surface and Underwater Launched Munitions).
- STANAG 4759 AAS3P-12 (Safety and Suitability for Service Assessment Testing for Aircraft Launched Munitions).
- STANAG 4761 AAS3P (Safety and Suitability for Service Assessment Testing of Large Caliber Ammunition Greater Than 40 mm).

Ammunition safety work is also closely linked to NATO working groups outside the ammunition safety area, for example STANAG 4370 Environmental Testing with associated AECTP:

- AECTP-100 - Environmental Guidelines for Defense Equipment,
- AECTP-200 - Environmental Conditions,
- AECTP-230 - Climatic Conditions,
- AECTP-240 - Mechanical Conditions,
- AECTP-250 - Electrical and Electromagnetic Environmental Conditions,
- AECTP-300 - Climatic Environmental Tests,
- AECTP-400 - Mechanical Environmental Tests,
- AECTP-500 - Electrical/Electromagnetic Environmental Tests,
- AECTP-600 - The Ten Step Method for Evaluating the Ability of Materiel to Meet Extended Life Requirements and Role and Deployment Changes.

Examples of standards

On the following pages, the standards are presented in tables in the above order.

In the tables below, you will find a selection of standards. For a more comprehensive list, please refer to FMV's website (www.fmv.se), FMV's intranet or NATO's website.

This handbook does not mandate which standards shall be used.

Standards relating to design and testing

Designation	Title
AOP-22	Design Criteria for and Test Methods for Inductive Setting of Electromagnetic fuzes
AOP-34	Vibration Tests Method and Severities for Munition Carried in Tracked Vehicles
AOP-39	Guidance on the Development, Assessment, and testing of Insensitive Munitions (MURAT)
DEF STAN 00 35	Environmental Handbook for Defence Materiel
DEF STAN 00 56	Requirements for the Analysis of Safety Critical Hazards
IFTEX	The Armed Forces' instruction for storage and transportation of ammunition and other explosives
H AmÖ	FMV Handbook of Regulations for In-Service Surveillance of Ammunition, M7762-000221 (not available in English)
MIL-HDBK-217	Reliability Prediction of Electronic Equipment

Designation	Title
MIL-STD-331	Fuze and Fuze Components, Environmental and Performance Tests for
MIL-HDBK-338-1	Electronic Reliability Design Handbook
MIL-STD-461	Requirements for the Control of Electromagnetic Interference Characteristics of Subsystems and Equipment
MIL-STD-810	Environmental Engineering Considerations and Laboratory Tests
MIL-STD-1316	Fuze Design, Safety Criteria for
MIL-STD-1466	Safety Criteria and Qualification Requirements for Pyrotechnic Initiated Explosive (PIE) ammunition
MIL-STD-1472	Human Engineering
MIL-STD-1474	Noise Limits
MIL-STD 1901	Munition Rocket and Missile Motor Ignition System Design, Safety Criteria for
MIL-STD 1911	Hand-Emplaced Ordnance Design, Safety Criteria For
MIL-STD-2105	Hazard Assessment Tests for Navy Non-Nuclear Munitions
NATO AASTP-1	Manual of NATO Safety Principles for the Storage of Military Ammunition and explosives
NATO AASTP-3	Manual of NATO Principles for the Hazard Classification of Military Ammunition and Explosives
SS-EN ISO 13850:2008	Machine safety – Emergency stop equipment – Design principles

Designation	Title
SS-EN 60825-1	Laser – Safety, equipment classification, requirements and user instructions
STANAG 3441	Design of Aircraft Stores
STANAG 4110	Definition of pressure terms and their interrelationship for use in the design and proof of cannons or mortars ammunition
STANAG 4123	Determination of the Classification of Military Ammunition and Explosives – AASTP-033
STANAG 4157	Fuzing System: Testing Requirements for the Assessment of Safety and Suitability for Service – with AOP-20, AOP-4157
STANAG 4170	Principles and Methodology for the Qualification of Explosive Materials for Military Use – with AOP-07
STANAG 4187	Fuzing Systems – Safety Design Requirements – med AOP-16
STANAG 4225	The Safety Evaluation of Mortar Bombs
STANAG 4238	Munition Design Principles, Electrical/ Electromagnetic Environments
STANAG 4240	Liquid Fuel/External Fire, Munition Test Procedures – with AOP-4240
STANAG 4241	Bullet Impact, Munition Test Procedures – with AOP-4241
STANAG 4297	Guidance on the Assessment of the Safety and Suitability for Service of Non-Nuclear Munitions for NATO Armed Forces – with AOP-15

Designation	Title
STANAG 4326	NATO Fuze Characteristics Data with AOP-88
STANAG 4370	Environmental Testing – med AECTP 100-600
STANAG 4382	Slow Heating, Munitions Test Procedure – with AOP-4797
STANAG 4396	Sympathetic Reaction, Munition Test Procedures
STANAG 4423	Cannon Ammunition (12,7 to 40 mm) Safety and Suitability for Service Evaluation
STANAG 4439	Policy for Introduction and Assessment of Insensitive Munitions (IM) – with AOP-39
STANAG 4452	Safety Assessment Requirements for Munition-Related Computing Systems – with AOP-52
STANAG 4496	Fragment Impact, Munitions Test Procedure – with AOP 4496
STANAG 4516	Cannon (12.7 to 40 mm), Design Safety Requirements And Safety And Suitability For Service Evaluation
STANAG 4517	Large Calibre Ordnance/munition Compatibility Design Safety Requirements And Safety And Suitability For Service Evaluation
STANAG 4526	Shaped Charge Jet, Munitions Test Procedure – with AOP-4526
STANAG 4629	AAS3P-01, Allied Ammunition Safety and Suitability for Service Assessment Testing Publication – Guidance

Designation	Title
STANAG 4758	AAS3P-11, Safety and Suitability For Service Assessment Testing For Surface and Underwater Launched Munitions
STANAG 4759	AAS3P-12, Safety and Suitability for Service Assessment Testing for Aircraft Launched Munitions
STANAG 4761	AAS3P- Safety and Suitability for Service Assessment Testing Of Large Caliber Ammunition Greater Than 40 mm
UN ST/SG/AC.10/1	Recommendation on the Transport of Dangerous Goods – Model Regulations
UN ST/SG/AC.10/11	Recommendation on the Transport of Dangerous Goods – Manual of Test and Criteria

System specific methods for environmental testing of ammunition

Designation	Title	Partial equivalence
FSD 0060	Safety testing of ammunition	AOP-15 STANAG 4297
FSD 0112	Testing of electric igniters with regard to electrical properties	MIL-STD 1512 SS 49907 01 STANAG 4560
FSD 0168	Environment types	SS 020121
FSD 0212	Testing of systems containing electric igniters	STANAG 4560
FSD 0213	Testing of fuze systems	MIL-STD 331 STANAG 4157

Appendix 3 Standards

Designation	Title	Partial equivalence
FSD 0214	Qualification of explosives for military use	AOP-7 STANAG 4170, 4363
FSD 0223	Shelf-life engineering	

Environment specific methods

Standards for mechanical testing of ammunition

Designation	Title	Partial equivalence
FSD 0098	Constant acceleration	DEF STAN 07-55 IEC Publ 68-2-7 MIL-STD 810D SEN 43 16 02 STANAG 4157
FSD 0099	Shock firing	STANAG 4363
FSD 0102	Sinusoidal vibration	DEF STAN 07-55 IEC Publ 68-2-6 SEN 43 160 06 STANAG 4157, 4224, 4325, 4337
FSD 0103	Jumbling	IEC Publ 68-2-32 MIL-STD 331 STANAG 4157
FSD 0104	Broadband random vibration	DEF STAN 07-55 IEC Publ 68-2-35 IEC Publ 68-2-36 MIL-STD 810D STANAG 4157, 4224, 4325, 4337

Designation	Title	Partial equivalence
FSD 0105	Free-fall drop from maximum 12 m	DEF STAN 07-55 IEC Publ 68-2-32 MIL-STD 331A SEN 43 16 05 STANAG 4157, 4224, 4325, 4337
FSD 0107	Free-fall drop from high altitude or equivalent	MIL-STD 331A
FSD 0113	Bump	DEF STAN 07-55 IEC 68-2-29 SEN 43 16 05 STANAG 4157, 4224, 4325, 4337
FSD 0114	Shock	DEF STAN 07-55 IEC 68-2-27 MIL-STD 810D SEN 43 16 05 STANAG 4157, 4224, 4325, 4337
FSD 0115	Shock with high peak value and short duration	STANAG 4157, 4224, 4325, 4337
FSD 0116	High-frequency transient vibration	STANAG 4157, 4224, 4325, 4337
FSD 0117	Small arms bullet attack	STANAG 4241
FSD 0118	Loose cargo	DEF STAN 07-55 IEC 50A MIL-STD 810C STANAG 4157, 4224, 4325, 4337
FSD 0120	Static load	DEF-STAN 07-55
FSD 0121	Fragment attack	AOP-39 STANAG 4439
FSD 0122	Shock waves in water	STANAG 4338

Appendix 3 Standards

Designation	Title	Partial equivalence
FSD 0123	Acoustic noise	STANAG 4325
FSD 0124	Recommended severity of mechanical testing	STANAG 4157, 4224, 4325, 4337

Standards for climatic testing of ammunition

Designation	Title	Partial equivalence
FSD 0044	Low barometric pressure and during change of air pressure	MIL-STD-810
FSD 0045	Humidity	MIL-STD-810
FSD 0059	Thermal shock and temperature change	
FSD 0072	Low temperature	DEF STAN 07-55 IEC Publ 68-2-1 MIL-STD 810 SEN 43 16 01
FSD 0073	High temperature	DEF STAN 07-55 MIL-STD 810 OEC Publ 68-2-2
FSD 0125	Salt mist	DEF STAN 07-55 MIL-STD 810D SEN 431610 STANAG 4157, 4224, 4325, 4337
FSD 0126	Water spraying	DEF-STAN 07-55 IEC 50B MIL-STD 810D SS-IEC 529 STANAG 4157, 4224, 4325, 4337

Designation	Title	Partial equivalence
FSD 0127	Simulated solar radiation	DEF STAN 07-55 IEC Publ 68-2-5 MIL-STD 810C STANAG 4157, 4224, 4325, 4337
FSD 0128	High water pressure	DEF STAN 07-55 IEC Publ 68-2-17 IEC 50B MIL-STD 331 MIL-STD 810D STANAG 4157, 4224, 4325, 4337
FSD 0129	Recommended severity of climatic testing	STANAG 4157, 4224, 4325, 4337

Standards for chemical testing of ammunition

Designation	Title	Partial equivalence
FSD 0130	Gaseous air pollutants and ozone	IEC Publ 68-2-42 IEC Publ 68-2-43 SIS 16 22 10 STANAG 4157, 4224, 4325, 4337
FSD 0224	Testing with contaminants	

Standards for electrical and electromagnetic testing of ammunition

Designation	Title	Partial equivalence
FSD 0046	Lightning	AOP-25 MIL-STD 1757A
FSD 0047	Static electricity	AOP-24 STANAG 4235, 4239

Appendix 3 Standards

Designation	Title	Partial equivalence
FSD 0100	Electromagnetic fields relevant to radar and radio radiation	MIL-STD 462 STANAG 4224, 4234, 4324
FSD 0101	Inductive interference of wiring	MIL-STD 462 RS 02 STANAG 4224, 4234, 4324
FSD 0106	Electromagnetic pulse, EMP	STANAG 4416
FSD 0112	Electric igniter tests: electrical properties (excluding EBW and EFI)	AOP-43 MIL-STD 1512 SS 49907 01 STANAG 4560
FSD 0119	Recommended severity of electrical and electromagnetic testing	STANAG 4234, 4324
FSD 0225	Testing of semiconductor components with regard to ionizing radiation	STANAG 4145, 4416

Standards for fire and explosion testing of ammunition

Designation	Title	Partial equivalence
FSD 0159	Gas pressure shock (explosive atmosphere)	STANAG 4157, 4224, 4325, 4337
FSD 0165	Fire	DEF STAN 07-55 STANAG 4240
FSD 0166	Cook-off	DEF STAN 07-55 DoD-STD 2105 STANAG 4382
FSD 0167	Recommended severity of fire and explosion testing	STANAG 4240, 4382

Standards for combined testing of ammunition

Designation	Title	Partial equivalence
FSD 0160	High temperature – Vibration	IEC Publ 68-3-51 STANAG 4157, 4224, 4325, 4337
FSD 0161	Low temperature – Vibration	IEC Publ 68-2-50 STANAG 4157, 4224, 4325, 4337
FSD 0162	High temperature – low barometric pressure	IEC Publ 68-2-41 STANAG 4157, 4224, 4325, 4337
FSD 0163	Low temperature – low barometric pressure	IEC Publ 68-2-40 STANAG 4157, 4224, 4325, 4337
FSD 0164	Recommended severity of combined testing	STANAG 4157, 4224, 4325, 4337

Appendix 4 References

For reasons of space, it has been necessary to restrict the number of references. They are classified according to:

1. Documents governing safety.
2. Design principles and experience.
3. Textbooks.
4. Documents relating to the environment.
5. Accident investigations etc.

The following acronyms and abbreviations of standards have been used:

AOC Proc	Australian Ordnance Council, Proceeding, AUS
AOP	Allied Ordnance Publication, NATO
DEF (AUST)	Australian Defence Standard, AUS
DEF STAN	Defence Standard, UK
DOE	Department of Explosives, USA
DOD- STD	Department of Defense Standard, USA
FSD	Swedish Defence Standards
GHS	Global Harmonized System, UN
GAM	Delegation General Pour l'Armement, FR
IEC	International Electrotechnical Commission
ITOP	International Test Operation Procedure, USA, DE
MIL- HDBK	Military Handbook, USA
MIL-STD	Military Standard, USA

Appendix 4 References

MSBFS	The Swedish Civil Contingencies Agency's code of statutes
NAVORD	US Naval Ordnance Laboratory, USA
OB Proc	Ordnance Board Proceeding, UK
SFS	Swedish Code of Statutes
SRVFS	The Rescue services Agency's code of statutes
SS	Swedish Standard
SSIFS	National Swedish Institute of Radiation Protection Code of Statutes
SSMFS	The Swedish Radiation Safety Authority's code of statutes
STANAG	Standardization Agreement, NATO
SÄIFS	National Swedish Inspectorate of Explosives and Flammables code of statutes
TDv	Technische Dienstvorschrift, Germany
TECOM	Test and Evaluation Command, USA
TjF FMV	Staff Regulations, FMV

Documents governing safety

In previous editions of the Ammunition Safety Handbook and H VAS, there have been references in this section to a large number of reports and documents. The list has been reduced in this edition.

Many publications are available today on the internet. Among other things, reference is made to the websites of the Swedish Work Environment Authority, FOI, MSIAC, NATO, NASA and the industries.

The reader is advised to ensure that the applied law/statute is up to date.

Designation	Title
AFS 2018:1	The Swedish Work Environment Authority's regulations regarding hygienic limit values
AFS 2009:07 with up-dates	The Swedish Work Environment Authority's regulations on artificial optical radiation
ST/SG/AC.10	UN Recommendations on the Transport of Dangerous Goods
Regulation (EC) No 1272/2008	On classification, labelling and packaging of substances and mixtures
H ProgSäk	FMV's Handbook on Software in Safety-Critical Applications
H SystSäk	Swedish Armed Force's System Safety Handbook
IEC 60825-1	Laser Classification and Safety
MIL-STD 882	System Safety Program, Requirements
MSBFS 2010:4	MSB's regulations on which goods shall be considered to be flammable and explosive, explosive, with change MSBFS 2018:12
SFS 1977:1160	The Work Environment Act
SFS 1977:1166	The Work Environment Ordinance

Appendix 4 References

Designation	Title
SFS 2006:263	The Transport of Dangerous Goods Act
SFS 2006:311	The Transport of Dangerous Goods Ordinance
SFS 1988:220	The Radiation Protection Act
SFS 1988:293	The Radiation Protection Ordinance
SFS 2010:1011	The Flammable and Explosive Goods Act
SFS 2010:1075	The Flammable and Explosive Goods Ordinance
SFS 2007:936	The Ordinance on the International Legal Review of Weapons Projects
SSMFS 2014:4	The Swedish Radiation Safety Authority's regulations and general advice on lasers, strong laser pointers and intense pulsed light with updates
SÄIFS 1999:2	Regulation on the handling of hydrogen peroxide

Design principles and experience

Designation	Title
The Ganssle Group, Baltimore, Jan 2004	Great Watchdogs, version 1.2
Ove Bring UD 1989:5	Humanitarian rights and weapons control
FMV-Vapen A 761:62/85	Risks involved in the use of glass fibre reinforced plastic as reinforcement material for explosives
FMV-A:A A761:3/82 1982	Final report of cavity group

Designation	Title
S Lamnevik FOA C 20302-D1	Explosive trains for detonation transmission
FMV-Vapen A761: 342 83/86	UK Qualification Programme for Introduction of PBX into Service
Ola Listh FOA rapport C 20228-D1 (D4) Mars 1978	Instantaneous point detonation super-sensitive m/484D – investigation of certain risks for inadvertent arming and initiation of composition dust
Ola Listh FOA rapport C 20457-D1 (D4) Del 1	Data for igniters in Swedish ammunition and knowledge status concerning testing

Textbooks

Designation	Title
FMV-A M77:21/79	Ammunition doctrine for the Army
AB Bofors Wezäta, Göteborg, 1960	Analytical Methods for Powders and Explosives
Rudolf Meyer Verlag Chemie, GmbH D-6940 Wein- heim, 1993 ISBN 3-527-28506-7	Explosives
G Blomqvist FOA-rapport A 1577- D1 1973	Explosives and their sensitivity properties. Fundamentals for future sensitivity research
S Lamnevik et al FOA 1983	Chemistry of explosives Revised extract from MHS compendium in chemistry 1972-11-06

Appendix 4 References

Designation	Title
Ingvar Sejlitz Nobelkoncernservice ISBN 9178108349, 9789178108343	Knowledge of explosives
Military Office of the Swedish Ministry of Defence ISBN 91-38-31004-X (M7740-804001)	International rules of warfare, conventions of international law applicable during wartime, neutrality and occupation
J M Mc Lain The Franklin Institute Press Philadelphia, 1980	Pyrotechnics
M7742-108001	Weapons doctrine for the Army

Documents relating to the environment

Designation	Title
Saab-Scania AB TCP-37-7.76:R2, juni 1979	30 mm automatic cannon m/75 Fuze accelerations with forced driving band
SAAB SAAB TCP-0- 72.33:R1	Acceleration measurement in fuze. Analysis of measuring methodology
René Renström FOA rapport C 2525- D3, 1972	Acceleration stresses in projectile-borne rocket propellant
ITT Research Institute (For Defense Nuclear Agency, Washington)	DNA EMP Awareness Course Notes, August 1973

Designation	Title
S Almroth FOA C 23204-41, 1969	Casting properties and sensitivity for octol
S Lamnevik FOA 1 rapport A1461143 (40, 41), januari 1969	Copper azide formation
Bofors KL-R6775	Sensitivity of octol NSV10 and octonal NSB 9030
Anders Schwartz FOA rapport A 20015-D1, mars 1976	Methods for testing rocket propellant. Double-base propellant
Anders Schwartz FOA rapport A 20031-D1, februari 1979	Methods for testing rocket propellant. II Composite propellant
S Lamnevik FOA A-1510-41(40), 1970	HMX. Basic data for technical specifi- cations
AB Bofors KL-R-5696, dec 1976	Risk for self-initiation of round rammed in a hot barrel
Institutet för vatten- & luftvårdsforskning IVL nr 02:0464, juni 1977	Collocation of the presence, content levels, and properties of gaseous air pollutants
AB Bofors KL-R 7742, nov 1982	Safety testing of ammunition with regard to resistance to cook-off
US Army TECOM Pamphlet No 310-4	Test Operations Procedures

Appendix 4 References

Designation	Title
AB Bofors KL-R-5776, dec 1976	Pressure and temperature in the air cushion in front of a projectile in a barrel
FOA 2 Reg nr 21840-X16, oktober 1976	Investigation concerning water shock wave severity at various distances from a detonating underwater mine
Anders Schwartz FOA rapport A 20016-D1 (D3), 1976	The influence of age on the adhesion of insulation on gas generator charges

Accident investigations

Designation	Title
A:VA 036577:91/70	Expert group for Ravlunda accident 1969. Final report
VA/034 201:40	Ag SAM, The Work Group on Ammunition Safety
FOA-rapport A 1520-40, 1970	Analysis of m/51 fuze clockwork as a result of the firing accident at Ravlunda
A:VA A684/24/71 1971-10-11	Expert group for the Grytan accident 1969
A:VA684:75/74 1974-10-02	Expert group for the Vaddö accident 1970
A:VA A684:80/73 1973-10-09	Expert group for the Kungsängen accident 1971
A:A M4808/4:6/78	Final report regarding accident when firing with 84 mm Carl Gustaf at InfSS in January 1978

Designation	Title
The committee (KN 1981:02) for investigation of serious accidents. Investigation report no. 2:1985	Firing accident at Stockholm coastal artillery defence force on 17 May 1984
S D Stein, S J Lowell Picatinny Arsenal 1957, PB 128 979	Initiation of Explosive in Shell Threads
Ordnance Corps (USA) Report No DPS-220	Report on Investigation of Premature Occurrence with Cavitated Composition B Shell, HE, 120-MM, T15 E3
R L Huddleston Aberdeen Proving Ground ADA 026 046	Diagnostic Significance of Macro- and Microscopic Features of Catastrophic Gun-tube Failures

Project Manager

Svante Wählin, FMV

Subject Experts

Peter Bergkvist, FMV

Per Cederberg, FMV

Sten Edström, FMV

Dag Persson, FMV

Gunnar Winblad, FMV

Translation

Svante Wählin, FMV

Mats Gustavson, FMV

Illustrations and cover

Leif Sundberg, Combitech AB

Mats Lundgren, Combitech AB

Original

Mats Lundgren, Combitech AB

Digital edition

Mats Lundgren, Combitech AB

FMV



Defence Material Administration
SE-115 88 STOCKHOLM, SWEDEN

M7762-001201

